

# Visual CADD 6.0

## User Guide



The material presented in this publication is copyright protected © 2001-2011 by TriTools LLC and may not be reproduced in any form, by any method for any purpose without the prior written consent of the copyright holders.

# Program License Agreement

**IMPORTANT NOTICE:** Please read the terms of the following License Agreement carefully. Your use of the product signifies your acceptance of the terms of the Agreement. Retain this License Agreement for future reference.

## Article 1: License Grant

The software is the intellectual property of TriTools LLC, dba TriTools Partners and its licensors, and is protected by law, including United States copyright laws and international treaties.

TriTools Partners grants to you a license:

1. To use the program on a single machine. The program may be used on a second machine so long as both machines are used by a single user and not at the same time, for example, office and home computers or desktop and notebook computers used by a single user.
2. To make a single archival back-up copy of the program in support of your use of the single program on a single machine.
3. To modify the program and/or merge it into another program of the licensee's own design and making for the licensee's own use on a single machine.
4. To use the program with third party commercial and/or freeware programs which are designed to be used as add-on custom command tools exclusively with and by the program and its user interface. Developers of any other third party commercial and/or freeware programs must obtain a separate license from the licensors and must provide certification of that license to the licensee upon request.
5. To transfer the program to another party if that party agrees to accept the terms and conditions of this Agreement, and you do not retain any copies of the program, whether in printed, machine readable, modified, or merged form. Except as expressly provided for in this license, you may not copy, modify, or transfer this program.
6. If the software in this package is licensed as a Site License, it is licensed for use on multiple machines. Additional master copies of the software may be made by the licensee, equal to the number of licenses purchased.

No reverse engineering. Except as stated above, YOU MAY NOT MODIFY, TRANSLATE, DISASSEMBLE, OR DECOMPILE THE SOFTWARE, OR ANY COPY, IN WHOLE OR PART.

## Article 2: Term

The license is effective until terminated. You may terminate the license at any time by destroying the program together with all copies, modifications, and merged portions in any form. The license will also terminate upon conditions set forth elsewhere in this Agreement, and TriTools Partners may terminate your license if you fail to comply with this Agreement. You agree, upon such termination for any reason, to destroy the program together with all copies, modifications, and merged portions in any form.

## Article 3: Disclaimer of Warranties and Limitations of Remedies

1. TriTools Partners software is licensed to you As Is. You, the consumer, bear the entire risk relating to the quality and performance of the software. In no event will TriTools Partners be liable for direct, indirect, incidental, or consequential damages resulting from any defect in the software, even if TriTools Partners had reason to know of the possibility of such damage. If the software proves to have defects, you, and not TriTools Partners, assume the cost of any necessary service or repair. In the event any liability is imposed on TriTools Partners, TriTools Partners liability to you or any third party shall not exceed the purchase price paid for this product.
2. Thirty-day limited warranty on media, for CD-ROM versions only. TriTools Partners warrants the enclosed disks to be free of defects in material and workmanship under normal use for 30 days after purchase. During the 30-day period, you may return a defective disk to TriTools Partners with proof of purchase, and it will be replaced without charge, unless the disk is damaged by accident or misuse. Replacement of a disk is your sole remedy in the event of a defect. This warranty gives you specific legal rights, and you may also have other rights which vary from state to state.
3. THE LIMITED WARRANTY STATED ABOVE IS THE ONLY WARRANTY OR REPRESENTATION OF ANY KIND WITH RESPECT TO THE SOFTWARE MADE BY TRITOOLES PARTNERS OR ANY THIRD PARTY INVOLVED IN THE CREATION, PRODUCTION, DELIVERY, OR LICENSING OF THE SOFTWARE. TRITOOLES PARTNERS AND ANY SUCH THIRD PARTY DISCLAIM ALL WARRANTIES, EXPRESS OR IMPLIED, WITH RESPECT TO THE SOFTWARE, ITS QUALITY, RELIABILITY OR PERFORMANCE; OR ITS MERCHANTABILITY, NON-INFRINGEMENT OF THIRD PARTY RIGHTS, OR FITNESS FOR A PARTICULAR PURPOSE.
4. Some states do not allow the exclusion or limitation of implied warranties of liability for incidental or consequential damages, so the above limitations or exclusions may not apply to you.

#### **Article 4: General**

You may not sub-license, assign, or transfer the license or the program except as expressly provided in this Agreement. Any attempt otherwise to sub-license, assign, or transfer any of the rights, duties, or obligations hereunder is void.

This Agreement will be governed by the laws of the State of Washington, and you agree that any claims regarding the software shall be brought in Washington. You acknowledge that US laws prohibit the export/re-export of technical data of US origin, including software, and agree that you will not export or re-export the software without the appropriate US and foreign government licenses.

## **Copyright Info**

**Copyright 2011 © by TriTools LLC. All rights reserved.**

#### **Visual CADD - Version 6.0**

The contents of the Visual CADD software and the associated manual are the property of TriTools LLC and are copyrighted. Any reproduction in whole or in part is strictly prohibited without written permission.

CD label and manual cover © 2011 TriTools LLC. Design and layout by Tif & Gif Creative, Friday Harbor, WA.

Redistributable portions of Microsoft MSVC and MFC are copyright of Microsoft Corporation. Microsoft, MS-DOS, Excel and Windows are registered trademarks of Microsoft Corporation.

Vector fonts (\*.VCF) were produced with FONTasm!-v2. FONTasm! is copyright © 1991-1998 G.Gibson & Associates

DWG read and write libraries © 1998-2011 Open Design Alliance. All rights reserved. OpenDWG is a trade mark of the Open Design Alliance.

DWGdirect © 2011 by Open Design Alliance Inc. All rights reserved.

AutoCAD is a registered trademark of Autodesk, Inc. Autodesk is a registered trademark of Autodesk, Inc.

TrueType is a registered trademark of Apple Computer, Inc.

All other brand and product names, fonts, and company names and logos are trademarks or registered trademarks of their respective companies.

Not all of the above referenced components are included in all versions of the software.

Background of v6 splash screen from a Visual CADD drawing courtesy of Wayne Fougere.



# TABLE OF CONTENTS

## Chapter 1: Introduction to Visual CADD

- Installing Visual CADD..... 1
- Using the Documentation..... 3
- Technical Support..... 5
- The Visual CADD Tutorial..... 7
- Starting Visual CADD..... 7

## Chapter 2: Getting Started

- Understanding CADD..... 9
- An Overview of Visual CADD Terms..... 10
- Starting, Saving, and Closing a Drawing..... 11
- Using Visual CADD to Match Your Working Style..... 12
- Planning Your Drawing..... 13
- Changing the Coordinate System..... 13

## Chapter 3: Setting up a Drawing

- Visual CADD Defaults..... 15
- The Settings Dialog..... 16
- System Settings..... 17
- General Settings..... 24
- Numeric Settings..... 26

## Chapter 4: Organizing your Drawing

- Using Layers to Manage a Complex Drawing..... 29
- Working with Layers..... 30
- Working with Layer Groups..... 32
- Assigning Properties to a Layer..... 33
- Using Styles to Maintain Standards..... 34

## Chapter 5: The Drawing Tools

- Introduction to the Drawing Tools..... 37
- Setting Properties..... 38
- The Straight Line Tools..... 39
- The Rectangle Tools..... 41
- The Polygon Tools ..... 42
- The Circle and Ellipse Tools..... 42
- The Arc Tools..... 43
- The Complex Curve Tools..... 44

|   |    |
|---|----|
| Point Basics.....                                   | 44 |
| Using Control Points to Change a Curve's Shape..... | 45 |
| Properties.....                                     | 46 |
| Line Scaling.....                                   | 47 |
| Isometric Mode.....                                 | 48 |

## **Chapter 6: Drawing with Precision**

|   |    |
|---|----|
| Constraining Lines and Objects.....           | 50 |
| Working with a Grid.....                      | 53 |
| Drawing Objects Precisely with Snaps.....     | 54 |
| Using Tracking to Place Temporary Points..... | 59 |

## **Chapter 7: Viewing the Drawing**

|   |    |
|---|----|
| Zooming and Panning.....                      | 61 |
| Birds-Eye View.....                           | 63 |
| Naming Views for Easy Reference.....          | 63 |
| Working on a Drawing in Multiple Windows..... | 64 |

## **Chapter 8: Modifying Objects**

|  |    |
|--|----|
| Selecting and Deselecting Objects.....               | 67 |
| Selecting Objects by Properties and Type.....        | 70 |
| Creating Groups.....                                 | 72 |
| Deleting Entities and Undoing Actions.....           | 72 |
| Viewing the Results of Your Edits.....               | 73 |
| Breaking Lines.....                                  | 74 |
| Extending Lines to Objects.....                      | 75 |
| Trimming Lines.....                                  | 76 |
| Reshaping and Moving Objects.....                    | 77 |
| Resizing Objects.....                                | 79 |
| Skewing an Object.....                               | 80 |
| Rotating Objects.....                                | 81 |
| Inserting a Chamfer or Fillet Between Two Lines..... | 82 |
| Exploding and Joining Objects.....                   | 84 |
| Creating Copies of an Object.....                    | 85 |
| Offsetting Objects from an Original Object.....      | 88 |
| Dividing Objects into Equal Parts.....               | 89 |
| Combining Objects to Create a New Object.....        | 89 |
| Draw Order.....                                      | 91 |
| Changing Properties.....                             | 91 |

## **Chapter 9: Dimensioning and Measuring**

|                                     |    |
|-------------------------------------|----|
| Adding Dimensions to a Drawing..... | 93 |
| Modifying Existing Dimensions.....  | 96 |

|   |     |
|---|-----|
| Adjusting Dimension Settings.....                       | 97  |
| Drawing Leaders.....                                    | 103 |
| Making Measurements and Getting Object Information..... | 105 |

## **Chapter 10: Working with Text**

|  |     |
|--|-----|
| Adding Text to a Drawing.....                  | 109 |
| Setting Text Properties.....                   | 111 |
| Modifying Text.....                            | 113 |
| Checking Spelling.....                         | 114 |
| Choosing Fonts.....                            | 115 |
| Font Manager.....                              | 116 |
| Converting AutoCAD and Generic CADD Fonts..... | 118 |

## **Chapter 11: Symbols and Hatches**

|  |     |
|--|-----|
| Using Symbols to Keep Drawing Elements Together.....       | 119 |
| Creating and Working with Symbols.....                     | 122 |
| Creating and Attaching Attributes to Symbols.....          | 124 |
| Rendering Objects with Hatch Patterns and Solid Fills..... | 126 |

## **Chapter 12: Practical & Advanced Techniques**

|  |     |
|--|-----|
| Setting Properties and Drawing Tools by Example..... | 129 |
| Setting Distances and Angles Quickly.....            | 131 |
| Inserting an Image.....                              | 132 |
| Bearings.....  | 133 |
| Adding Reference Frame Entities to Your Drawing..... | 135 |
| Adjusting a Reference Frame Entity.....              | 137 |
| Using a Digitizer.....                               | 139 |
| Running Visual CADD at Top Speed.....                | 141 |

## **Chapter 13: Customizing Visual CADD**

|  |     |
|--|-----|
| Automating Actions with Scripts.....                 | 143 |
| Custom Commands.....                                 | 146 |
| Customizing Keyboard Shortcuts.....                  | 147 |
| The Configuration Editor.....                        | 148 |
| Creating Custom Menus.....                           | 149 |
| Customizing Context-Sensitive Right Mouse Menus..... | 151 |
| Customizing Toolbars.....                            | 153 |
| Creating New Hatch Patterns.....                     | 155 |
| Creating New Line Types.....                         | 157 |

## **Chapter 14: Working with Other Applications**

|   |     |
|---|-----|
| Copying Objects Between Visual CADD Drawings.....       | 161 |
| Copying Between Visual CADD and Other Applications..... | 162 |

|  |     |
|--|-----|
| Linking and Embedding Objects (OLE).....           | 163 |
| Creating Export Files.....                         | 165 |
| Sharing Files with AutoCAD and Generic CADD.....   | 167 |
| AutoCAD and Generic CADD Translation Settings..... | 168 |
| Adjusting Font Mapping.....                        | 170 |
| Adjusting Color Mapping.....                       | 171 |

## **Chapter 15: Printing and Other Output**

|   |     |
|---|-----|
| Printing Your Drawing.....                  | 173 |
| Print Presets.....                          | 177 |
| Output as PDF.....                          | 178 |
| Output as Image.....                        | 179 |
| Using Direct Plotting.....                  | 180 |
| Making a Custom Plotter Configuration.....  | 182 |
| Increasing Printing and Plotting Speed..... | 183 |

## **Appendix A: Keyboard Shortcuts & Native Commands**

## **Appendix B: Linetypes & Linewidths**

## **Appendix C: Entering Numbers in Visual CADD**

## **Index**

# INTRODUCTION TO VISUAL CADD

Visual CADD is highly productive design and drafting software. Compared to many other programs, Visual CADD is easier to use, has a short learning curve, and is fast. But it is also very powerful.

Whether you are new to CADD or an experienced CADD user, Visual CADD will help you become super-productive in your work. You'll find everything you need to know to get started in this manual.

## Installing Visual CADD

---

Visual CADD has very modest hardware requirements, as shown in the following table, and will perform well on an older computer system. However, a more powerful computer and increased memory will always have an impact on the speed that the program runs at, increasing your productivity.

### System Requirements

| Component        | Minimum                          | Recommended                         |
|------------------|----------------------------------|-------------------------------------|
| CPU              | Pentium                          | Pentium 4 or greater                |
| Operating System | Windows 98                       | Window 2000, XP, Vista or Windows 7 |
| Memory           | 1 gigabyte MB                    | 2 gigabyte or greater               |
| Disk Space       | 30 MB                            | 40 MB                               |
| Display          | 800 x 600 SVGA (256 colors)      | 1024 x 768 or greater               |
| Pointing Device  | Mouse and/or Digitizer tablet    | Mouse and/or tablet                 |
| CD-Rom           | 2x                               | any current CD/DVD drive            |
| Web Browser      | Microsoft Internet Explorer 7.0+ | MS Internet Explorer 8 or 9         |

**NOTE:** +Internet Explorer 7 and WinXP service pack 2 are minimum requirements for using the Adobe Reader 9.

You don't need to use Internet Explorer as your default web browser if you prefer an alternate such as Firefox or Google Chrome, but Explorer must be installed on the system in order to view the Visual CADD Help files.

## Preparing for Installation

---

Before installing Visual CADD, check the following:

- Do you have the minimum system requirements?
- If you are upgrading, have you backed up all files that you customized in the previous version? These might include menus, toolbars, hatches, scripts or other editable files. This is important as all these files have the new XML format in Visual CADD 6. If there is a problem in converting the older file, you will want to have a backup to retry the conversion.
- If the operating system is Win2000 or later, do you have Administrator or Power User rights? If not you may not have the necessary permissions to install Visual CADD on your system. If you are not sure, see your Windows settings and documentation for more information, or contact your network administrator.
- Temporarily disable any virus checking software before installing. Some, though not all, of the anti-virus programs will treat the install files as a virus and will not allow the installation to complete successfully.

---

**Tip** We strongly recommend that you close any open programs before beginning the install. This will free up additional memory that may be required.

---

## To install Visual CADD from a CD

---

1. Insert the VCADD 6 disk in your CD-ROM drive and an install screen should appear. Click on the [Install Visual CADD] button and a dialog pops up to begin the installation process. Follow the instructions on each screen until the Visual CADD install is completed.
2. On some systems, the install screen might not automatically appear. If nothing happens after you insert the CD-ROM, select the Start button, then Run, and in the dialog that appears type D:\setup.exe (if D is your CD-ROM drive), then click [OK].
3. Follow the directions on the screen.

### Install Options

During the install process a dialog will pop up with several checkboxes that allow you to customize and add only a subset of the default install. The choices include sample files for drawings, styles, symbols and macros as well as font files, and a thumbnail

viewer that will show VCADD drawings in Windows Explorer. Unless you are an experienced Visual CADD user and know exactly which features you need, we recommend that you make no changes on this screen and instead do a default installation. You can add the other items at a later time.

## To Start Visual CADD

Click the Start button, then select Programs>Visual CADD 6.0 and then Visual CADD 6.0 on the flyout menu, *or* double click the shortcut icon on the desktop if you elected to add it during the installation process.

When you first open the program you will be prompted to input the User ID and keycode received when you ordered the software. Entering these codes will register the software. Until that happens, the program runs in demo mode and expires 30 days from the date of install. We suggest you print out and keep a copy of the ID and keycode with the this User Guide in case you need to reinstall Visual CADD in the future.

## Additional CD Contents

The CD contains additional software and files that are not part of the Visual CADD installation. If you purchased a downloadable version of v6 without the CD, all the software and files are available for download at the TriTools website:

**Symbols** - only a small subset of symbols are installed with Visual CADD. There are 15,000 symbols on the CD, covering a wide range of disciplines including the architecture, mechanical and electrical fields. For information on adding any of these symbols to your hard drive, see the file *Symbols.txt* in the Symbols folder on the CD.

**House plans** - almost 300 sample house plans are included in the Visual CADD drawing file format (*vcd*). Many also have a bitmap of the same name showing a photograph or perspective rendering of the house.

**Adobe Reader 9.0** - install this software to open, view and print Portable Document Format files. Use it to check PDF files you have created in Visual CADD, before sending them to clients or associates. If you are a new user, you will open the Reader to view and print the tutorial, as described below.

## Using the Documentation

---

The Visual CADD documentation set includes:

- The Visual CADD User Guide (the book you are reading)
- Online Help

## Using the Manual

---

This manual provides an introduction to Visual CADD and basic information on all of the Visual CADD features. You may be reading a paper copy if you purchased the CD, or a PDF version if you ordered version 6 online without the CD.

The manual is intended as a general reference and introduction to tools and features. For complete, detailed step-by-step instruction on each tool, refer to the Help file that is opened from the Help menu within the program.

This manual uses the following typographic conventions:

- Keyboard keys (Hotkeys) are in SMALLCAPS, (For example: Press ENTER, TAB, SHIFT or ESC).
- Key combinations (more than one Hotkey needed to execute a command) are joined by a plus sign, (For example: Press ALT+A means to hold down the ALT key on the keyboard while you press the letter A).
- Buttons and tabs on the screen are enclosed by straight brackets ([ ]), (For example: Click [OK], [Cancel], or [Help]).
- Visual CADD filenames are usually shown in all capital letters (For example: MAINSBAR.VCTBR), and sometimes in *italics*.
- Pulldown menu instructions are separated by an angle (>), (For example: File>Open means to select the File menu and choose the Open menu item).

## Using Online Help

---

Detailed information about Visual CADD is always at your fingertips while working in the program.

### To access online help:

Choose Help>Visual CADD 6.0 Help.

## Using Context-Sensitive Help

---

Context-sensitive help provides instant information about an item on the screen.

You can activate context-sensitive help in several ways:

- Once a command is started, press [F1] to pop up a Help dialog for that command.
- All speedbars have a help button. Click it and the Help topic for that command will appear.
- In the titlebar of an onscreen dialog, click [Help]  to open a help topic screen with a description of the features and tools on the dialog.

---

**Tip** New in Visual CADD 6, you can choose to assign a Script to the F1 key to run a command or string of commands, instead of starting a Help dialog.

---

## Technical Support

---

Tech support for Visual CADD 6 is e-mail and Internet based. We will attempt to respond to your request as soon as possible. Please provide your phone number with all correspondence --if we can't solve the problem online we'll call you on our nickel and try to work it out.

Sometimes, a problem can be traced to hardware, or to another software application that is interacting with Visual CADD. Our engineers will supply as much support as possible in these cases, but they cannot guarantee to fix the problem or support products manufactured or published by another company.

The more detailed information you can provide, the better chance that your problem will be resolved.

### Technical Support Checklist

---

To receive the best response to your questions, complete the following checklist before you contact us:

- Please don't assume that we already know about your problem. It might be a bug that has not previously been discovered. A one or two line post usually does not give us enough information to resolve your issue. Give us very specific details.
- Check this User Guide and the Help file thoroughly for possible solutions. Let us know what solutions you have tried.
- Record the exact sequence of events that created the problem. Make sure that you can reproduce the problem by following the same series of steps, and describe those steps to us.
- Have the name, version number, and file date of the application. To get the exact version number of VCADD, select Help>About Visual CADD 6.0.
- Let us know the type of computer and Windows version you are using. For Print or Plot problems, provide the manufacturer and model number of the hardware, the version number of the printer driver, and whether it is on a network or standalone.
- Record the exact wording of any error messages. Some message boxes allow you to select the text and use the CTRL+C and CTRL+V key combinations to copy and paste the text into another document such as an e-mail message.

## Support Options

---

We are committed to trying to solve any problems you are having with Visual CADD. Please post via e-mail and we will answer as quickly as we possible. The best time to contact us is between 9 AM and 5 PM Pacific Standard (or Daylight) time, except on weekends and US holidays, but we'll try to help at other times as well.

Send e-mail to **support@tritools.com**.

Occasionally after you contact us with your initial report we will ask for a drawing file to help better understand the problem. Please compress the file(s) with a zip utility and upload to **support@tritools.com**.

When you reach us via the Web, click on the **Support** link on the main TriTools page to access the support options. There you can link to a user forum, a knowledge base, software patches and other files, links to information for 3rd party developers, and other support information. You can go directly to the support pages by typing:

**<http://www.tritools.com/support.htm>**

If you do not have access to e-mail or the Internet, please send any tech support problems to the fax number **(360) 378-8786** and we will call or fax you back to try and resolve the problem.

## Customer Service

---

TriTools Partners offers sales & customer service via the phone and Internet.

|  |  |
|--|--|
| E-mail address                         | <b>sales@tritools.com</b>  |
| Customer Service (for non tech issues) | <b>1+(360) 378-2023</b>  |
| Direct Sales                           | <b>1+(360) 378-2023</b>  |
| Fax Number                             | <b>1+(360) 378-8786</b>  |
| Online Store                           | <b><a href="http://www.tritools.com">http://www.tritools.com</a>, then click on Purchase</b> |

## Additional Support

---

The *Visual CADD Group* is an independent non-profit users' group that provides tremendous peer-to-peer support for Visual CADD users. Visit their web site at:

**<http://tech.groups.yahoo.com/group/visualcadd/>**

The main value is the users forum where you can expect quick answers to your questions. When you join, there are also links to to valuable websites related to CADD, and files to download for customizing and enhancing Visual CADD.

# The Visual CADD Tutorial

---

If you are brand new to Visual CADD, we recommend that you run our tutorial for an introduction to the workspace and commands. The tutorial provides five lessons that will teach you the basics of Visual CADD. The lessons are based on the typical process of creating, editing and printing a drawing. The tutorial won't take long to complete and will teach you what you need to know to start creating your own drawings.

In these lessons you will construct a floor plan of an apartment (the illustration on the next page shows the completed tutorial drawing). Visual CADD is used of course in many different industries and applications; the techniques that you learn here can be applied to any type of drawing.

The 23 page *tutorial.pdf* file is located in the Tutorial folder of your installation. The location of the folder varies depending on which version of Windows you are using. See the *Getting Started* book of the Help file and the topic *Running the Tutorial* to find the location.

Use Adobe Reader software to open and print the contents of the PDF file.

## Starting Visual CADD

---

Run the program from the Start menu or a desktop shortcut. The Visual CADD drawing board contains a menu bar, main toolbar, side toolbar and status bar. As you work, you can zoom in and out as far as you want, because the drawing area has no limits or page boundaries.

Visual CADD starts with a blank drawing titled *Drawing-1*. To work on an existing drawing, select File>Open, and then find its folder, or select a recently opened drawing file from a list at the bottom of the file menu.

If you are a new user starting Visual CADD for the first time, you might open one of the included sample files from the *Drawings* folder.

You can open and view up to 64 drawing files at one time, depending upon the memory available on your computer.

Once you have finished working on a drawing in Visual CADD and have saved it, select File>Close to close the drawing. When you have completed a work session, select File>Exit to leave the program.

The illustration on the next page shows the workspace and provides details on the most common elements of the interface.

# A tour of the Visual CADD workspace

The main toolbar changes to a "speedbar" when a tool is started, and displays options and settings that are specific to that tool.

The cursor varies in appearance depending on the tool you use and the task you perform.

The side toolbar gives you quick access to the most common drawing tools and other important commands. Click and hold down the left mouse button on an icon to display a flyout of related tools. You can drag and drop this toolbar to dock it on either the left or right side of the drawing.

The drawing board has no limits or page boundaries, so you can draw in real world units at 1:1 and then later set a print scale for output to a specific paper size.

The status bar lists the basic information of a selected entity in the drawing, and also prompts for the next step of a tool that is running. Right click anywhere on the status bar to pop up a menu with a list of commands. You can also toggle Ortho Mode on or off, or change the coordinate entry mode, by clicking on those sections of the status bar.

The menu bar displays Visual CADD's command and options menus.

The properties dropdowns on the main toolbar set the layer, color, line type and line width properties for objects you draw. You can also change selected objects already placed in the drawing.

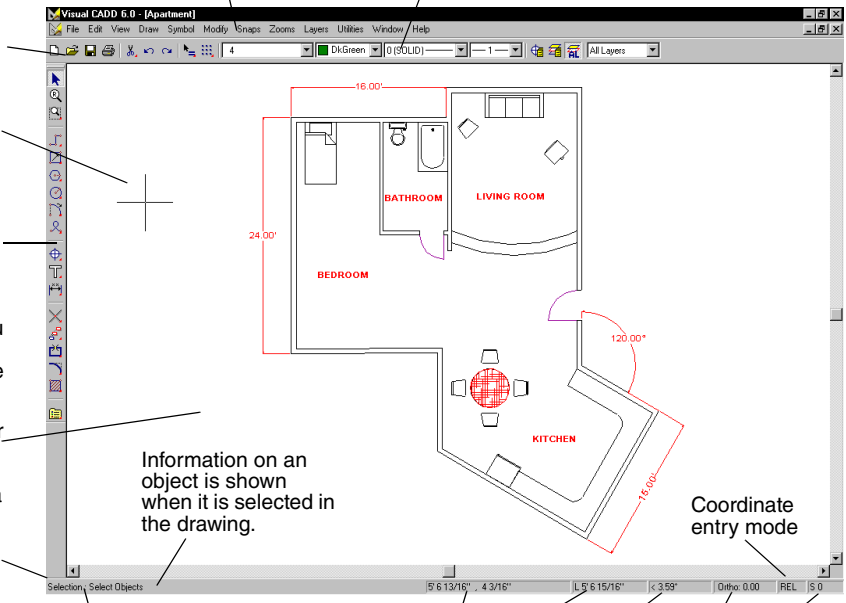

Information on an object is shown when it is selected in the drawing.

Prompt area shows the next step when a command is running

Coordinates

Current length

Current angle

Coordinate entry mode

Number of selected objects

Ortho mode on/off with current ortho angle shown when ortho mode is on

# GETTING STARTED

This chapter introduces some of the basic concepts of Visual CADD. If you are an experienced user upgrading from an earlier version, you may want to skip this section and check out the Help file to see a complete list of the new features in version 6.

If you are migrating from another CADD program --and particularly if you are making the move from pencil and paper drafting to CADD-- you should read the information in this chapter before you start drawing or changing Visual CADD's default settings.

As a first step, we recommend that you run the tutorial described in Chapter 1, and refer to the information in this chapter as needed during the process.

## Understanding CADD

---

In conventional drafting, you draw objects at a scale different than their actual size because paper dictates the size of your drawings. When you draw on paper or film with a pencil or pen, you have to place each line or arc or other object precisely at the scale that you will print it: for example 1/4"=1'0" or 1:150.

In Visual CADD, you always draw at real world scale (1:1), and then specify the output scale when you print.

Computer aided design and drafting (CADD) creates a database of coordinates in two dimensions that closely mimics three dimensional reality.

In conventional drafting you draw each line precisely. In Visual CADD you place the points necessary to define endpoints, corners, centerpoints, vertices, foci, and control points of drawing entities. Visual CADD creates the objects from the coordinate information of these points. Place points quickly and precisely by typing the X and Y coordinates or more typically by using a method called *direct distance entry*.

The coordinate system you choose will have an effect on how and where points are placed in your drawing. The coordinate system can be changed as you work so that points are placed in reference to the absolute drawing origin, a basepoint you specify, or the last point entered, depending on which is most efficient for the type of drawing you are creating.

# An Overview of Visual CADD Terms

Some terms might be unfamiliar if you are new to computer aided design and drafting. The illustration below will help you understand the basic terms used to describe parts of a CADD drawing. Note that some of the familiar terms that you used in conventional drafting take on new meaning in the CADD world.

For example, in Visual CADD, the lines you draw are called entities or objects. Individual entities can be combined to form symbols, such as a door, a stairway, or a table, that can be reused without having to draw each object again. Text is not just a group of individual characters, but instead a *block* that contains settings for properties such as font, height, justification etc, that are applied to the text as you enter it. Hatches are not a series of individual lines; they are an object that is typically applied to a closed area defined by other objects such as lines, circles and rectangles. A hatch object has predefined properties such as pattern, scale, angle and color.

## Parts of a Visual CADD drawing

**Objects**, also called entities, are the building blocks of a Visual CADD drawing. Each arc, line, symbol, text block, and dimension is a separate object.

**A symbol** groups entities to form a single object. This television was first created with several individual lines and arcs. Once saved to disk as a symbol, it can be used in other drawings without having to draw the separate objects again to recreate the television. You can create your own symbols and use predrawn symbols provided with Visual CADD.

**Dimensions** associate with, or attach to, an object. When you resize both the object and its dimension with the Stretch command, the dimension updates to show the changes.

**Text strings** are placed as a block. You can resize, move, and edit each text block and change its properties separately from other text blocks.

**Hatches and fills**, like dimensions, are associative. When you resize the bounding box that contains a hatch or fill with the Stretch command, the hatch or fill also changes.

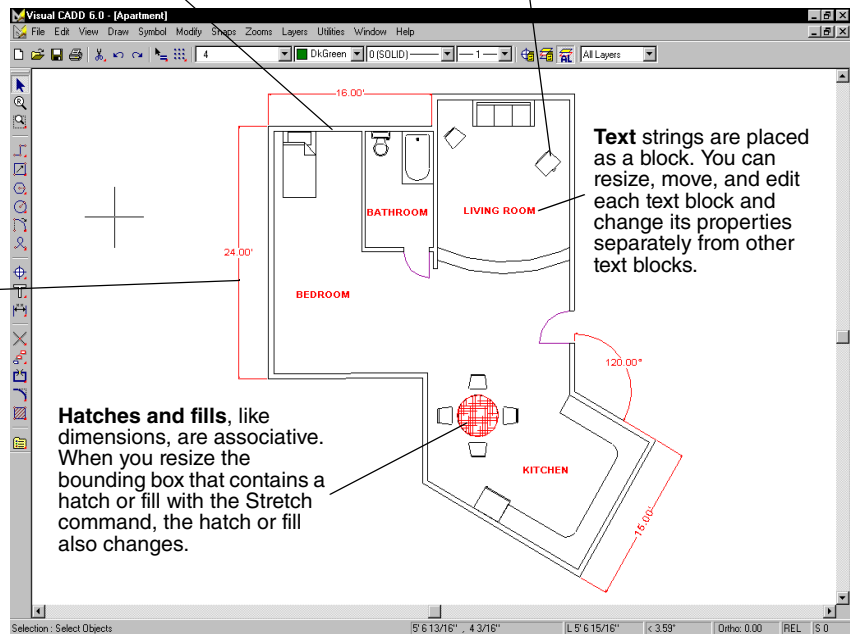

# Starting, Saving, and Closing a Drawing

---

When you start Visual CADD, a new drawing opens with the title *Drawing-1*. Once Visual CADD is running, you can open another new drawing file or an existing one. You can open and view up to 64 drawing files at a time, depending upon the memory available on your computer.

Save a Visual CADD drawing before closing it as you would do in any Windows application, or save it with another name to create a new drawing while preserving the original drawing file.

If you are sharing drawing files with other Visual CADD users on a network, you can lock Visual CADD drawing files so that only one person can make changes to them at a time, enabling you to control which drawing is the most recent version.

You can save one or more backup copies of a drawing at a timed interval you specify, as a safeguard in case the original drawing becomes corrupted. Autobackup is not turned on by default; it can be set on the Utilities>Settings>System2 dialog. A backup is always opened as a Read-Only file, so you must save it as a Visual CADD .vcd file with another name via the *SaveAs* command to create the new file.

You can also Autosave drawings while working, at a timed interval you specify.

| To...  | Do This...  |
|--|---|
| Start a new drawing  | Select File>New.  |
| Open an existing drawing                                     | Select File>Open, find the path and filename, and then click [Open].  |
| Save a drawing   | Select File>Save. If you are saving the drawing for the first time, type a name and then click [Save].                                    |
| Save a drawing under another name                            | Select File>Save As, type a different name, and then click the [Save] button on the dialog.   |
| Lock a drawing for version control when working on a network | Select Utilities>Settings>System2 dialog, and under the <i>File Management</i> section make sure <i>Use File Locking</i> is checked.      |
| Close a drawing  | Select File>Close. Visual CADD prompts you to save the drawing if it is "dirty" --if it has not been saved since you last modified it.    |
| End a Visual CADD session                                    | Select File>Exit Visual CADD. If the file is dirty you will get the prompt described above.   |
| Open a backup drawing file                                   | Select File>Open, in the Files of Type dropdown choose "Visual CADD Backup (*.vb.*);", find the path and filename, and then click [Open]. |

---

# Using Visual CADD to Match Your Working Style

You can start almost any task in Visual CADD at least three different ways. If you are new to the program, use a mouse or digitizer puck to choose commands and tools from the top level menu. Then right click when a command is running to pop up a context sensitive menu with a list of commands and settings pertinent to that tool.

As you become more familiar with the commands you might start using the buttons on the toolbars to run your most frequently used commands.

The real power of Visual CADD however is with the 2 and 3 letter keyboard shortcuts. They will speed up your productivity by reducing the number of mouse moves that are needed to run a command from a menu or toolbar. You will see increased production every day even if you only memorize the shortcuts for a half dozen or so of your most used commands.

You can assign scripts to the function keys and other keys as well as mouse and digitizer buttons to run command sequences. You can create new menus and toolbars, or customize the existing ones with commands, options, and tools you use most often.

## Ways of Working in Visual CADD

- Use a mouse or digitizer puck to choose a command or tool from the top menu. Or right click to use context sensitive commands from a popup menu after starting a command, as shown at right.
- Enter 2 and 3 letter keyboard shortcuts for commands, tools or options. You don't need to press ENTER after the keyboard shortcut to start the command.
- Assign scripts to function keys and mouse and digitizer buttons to automate a command or a linked series of commands.
- Use a mouse or digitizer puck to click buttons and select options on the main and side toolbars. Most commands start a speedbar, as shown below, where you can further set options for how the specific command runs.

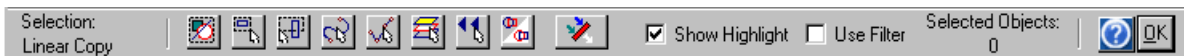
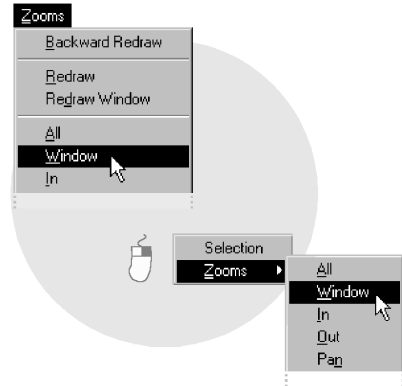

Whether you choose to start a command from a menu, a toolbar, or by entering a keyboard shortcut, the status bar at the bottom of the screen displays the command and provides you with prompts to guide you through all steps of the task or tool.

# Planning Your Drawing

---

There are several considerations to take into account before you start a drawing. Planning ahead will help keep you from having to make wholesale changes later.

## Setting a Measurement System

---

In Visual CADD, you can enter numeric values using fractional feet and inches, decimal feet and inches, millimeters, centimeters, meters, kilometers and miles. Dimensions can contain up to two different measurement units. By default Visual CADD is set at Decimal Inches when you first start the program, but it can be changed at any time from the menu via the Utilities>Settings>Numeric dialog. Please see Appendix C for more information on entering numbers in Visual CADD.

## Setting Layers

---

In paper drafting, you sometimes key separate drawings to a particular point on each sheet of paper and overlay them. In Visual CADD you can key all parts of your drawing to a single origin point (0,0), or basepoint, or survey monument, enabling you to easily draw all parts of a drawing in the same file rather than on separate sheets. You could draw all objects on a single layer, but typically you will create different layers for related groups of objects (for example: lower floor plan, upper mechanical plan), and then display only the layers you want to work with or print. Layers and layer management is described in detail in Chapter 4.

## Setting a Scale

---

Once you've completed a drawing in Visual CADD, you can print it on paper or film, export it in PDF format, as a print or XML file, or as a graphics file such as BMP or JPEG. Whatever the final output, your drawing should be at a scale that legibly conveys the information you want to communicate. The most important task is planning the size of text and dimensions beforehand so that they are neither too small to read nor too large when you print. Chapters 9 and 10 discuss dimensions and text. A bit of experimenting with different sizes at your planned output scale(s) will quickly establish standards that you will use for printing or exporting drawing files.

# Changing the Coordinate System

---

In Visual CADD, construction points, which have a location, a distance, and a direction, define each entity that you draw. For instance, to draw a 2-point circle, you specify the circle's center and the point at a certain distance from the center (its radius). To draw a single line, specify the two endpoints.

Where these construction points begin and end when you place them depends on the coordinate system that is current in Visual CADD at that time.

Set one of the three coordinate systems as your default, and switch between them as needed.

## Overview of the Three Coordinate Systems

---

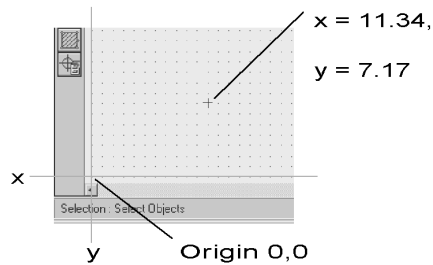

### Absolute Coordinates

All distances are measured along the X and Y axis from a fixed origin, with coordinate 0,0 at the lower left corner of a new drawing file.

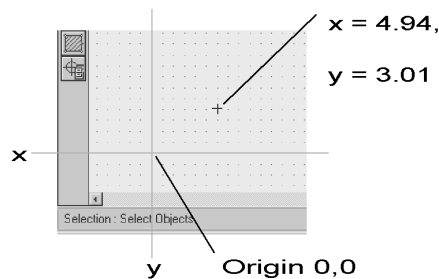

### Basepoint Coordinates

Distances are measured along the X and Y axis from a temporary origin, set with the *Set Basepoint* command on the Manual Entry submenu of the Snaps menu. For example, when drawing a house far from the true origin, you might want to set a corner of the house as the basepoint.

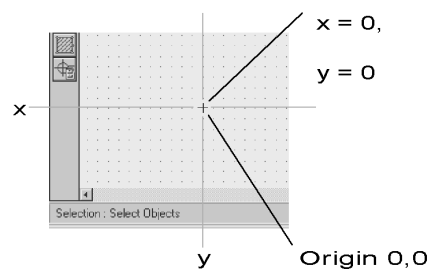

### Relative Coordinates

Distances are measured along the X and Y axis from the last point entered. For example, when breaking a line a specific distance from its end, you might want to set the coordinate system to Relative to locate the break a specific distance from one end of the line.

### To set the coordinate system:

From the menu select Snaps>Manual Entry, and then select an option, *or*,

Select Utilities>Settings>Constraint and select an option in the Manual Entry section, and then click [OK].

---

**Tip** Change coordinate system options quickly by clicking on the coordinate system section of the status bar (second from right) until you see the option you want.

---

## SETTING UP A DRAWING

Before beginning to draw, set up Visual CADD to help you work most effectively. You can change a wide variety of settings: everything from whether scrollbars are displayed at the bottom and right side of the screen to the width between the lines of the double line tool and whether it will be filled with a solid color.

This chapter covers the System and Path settings that apply to the overall drawing environment, and the General and Numeric settings that are saved with each specific drawing but also affect every new drawing file that you open. Later chapters will explore settings for text, dimensions, hatches and other specific object types.

### Visual CADD Defaults

---

Visual CADD ships with default settings that control the coordinate system, units of measurement, tool parameters and other elements of all new drawings you create. You can modify any of these to suit your work.

Initially, you might want to change only the appearance and behavior of Visual CADD's basic features. For example, you can choose a different default tool, change the size and color of the cursor, change the color of the drawing background, and display or hide various drawing elements. As you gain more experience working with Visual CADD, you can customize the settings further to match the way you work.

### Some Default Settings

---

The default Visual CADD cursor size is set at one screen inch, but you can resize it in the *Tools* section of the *System1* dialog on the Utilities>Settings menu. For a full screen cursor as shown in the illustration at lower right, set the size to zero. Run the *Save Current Environment* command (from the Utilities menu) or type **EN** to make this and any other changes “stick” the next time you open Visual CADD. Otherwise the settings will revert back to the original.

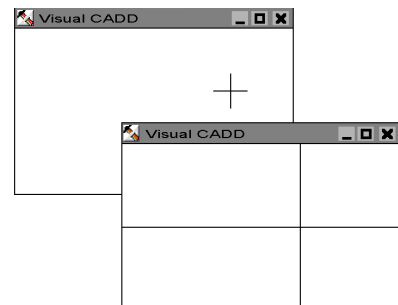

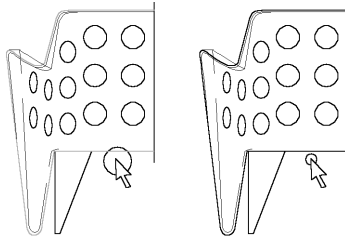
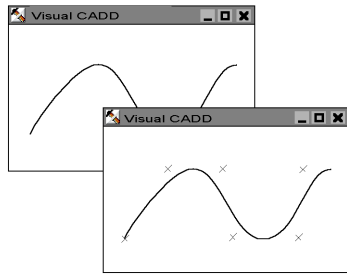

By default, line types, line widths, fills, hatches, and points are all displayed. You can also set construction and handle points to be displayed as shown in the lower left illustration. The more items you display, however, the longer it takes to redraw the displayed objects. This is generally only a problem on older machines or those with limited amounts of memory.

By default, the cursor must be within .25 or 1/4 inch of an object when you click to select it. You can change the search tolerance to a larger or smaller distance in the *Selection* section of the *System1* dialog on the Utilities>Settings menu.

## The Settings Dialog

Most of the settings in Visual CADD are found on the Utilities>Settings dialog. It has a brand new look in version 6, often called a “tree” dialog because there are a number of dialog screens selected from a list (or tree) on the left side.

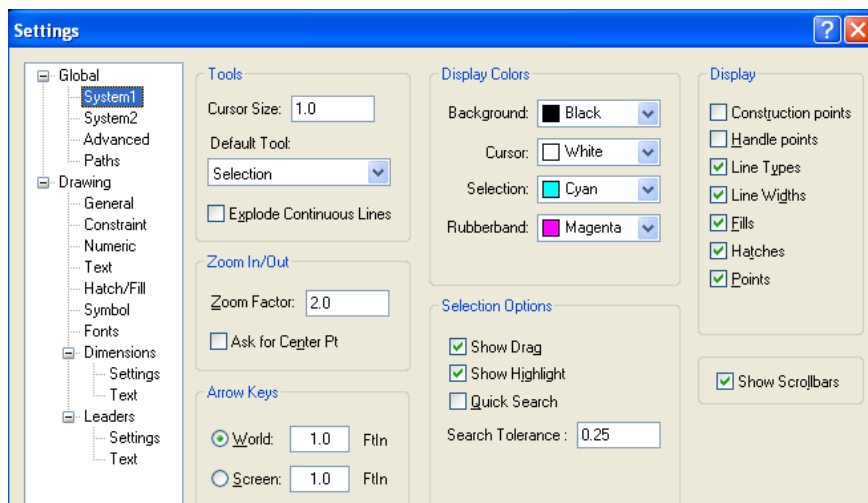

This illustration shows the System1 dialog. Note that some of the settings dialogs are Global and affect all drawings that are open. Others include settings that are saved with each drawing. All versions of Visual CADD have this same mix of global and drawing settings. The new tree dialog gives a better visual clue than earlier versions.

# System Settings

The system settings are found on the *System1*, *System2* and *Advanced* dialogs on the Utilities>Settings menu. System settings are global and affect all drawings that are open in the current Visual CADD session.

## System 1 dialog

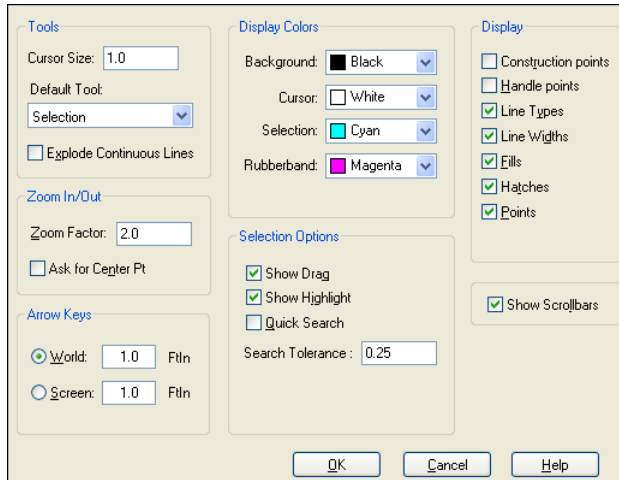

Open the System 1 dialog from the *Settings* item on the Utilities menu or by typing **TBS**. These settings change the drawing environment. For example, turning off the display of hatches in the current drawing also turns them off in all other open drawings, and any new drawing you open, until the setting is toggled back on.

### Tools

**Cursor Size** - sets the size, in inches, of the crosshairs of the

cursor. For a cursor that spans the entire screen, type 0.

**Default Tool Option** - sets the active tool in new drawings and the tool that Visual CADD reverts to after completing most operations.

**Explode Continuous Line** - sets Visual CADD to draw continuous lines as a series of single lines rather than as a single object. When unchecked, lines are drawn as a single entity (sometimes also called a polyline). This setting also applies to 2 and 3 point Rectangles, Center Regular Polygon, and Irregular Polygon.

### Zoom In/Out options

**Zoom In Factor** - sets the multiplier used to change the drawing magnification when the Zoom In command is used. The factor for the Zoom Out command is the reciprocal of this number.

**Ask for Center Pt** - Specifies if Visual CADD will prompt you to pick a point on the screen before performing any zoom in or zoom out operations. This point becomes the center of the new view displayed on the screen.

## Arrow Keys

**World** - Sets the real-world incremental distance that each arrow key will advance the cursor.

**Screen** - Sets the on-screen incremental distance each arrow key will advance the cursor. This incremental distance remains the same even when the zoom value changes.

## Display Colors options

These options set the color of the drawing background, cursor, selected objects, and the rubberband line. The Selection color is the *Highlight* shown when you select an object, while the Rubberband color is shown onscreen while moving the cursor in a direction to draw or modify (e.g. Move) an object. It disappears when you set a point and complete a command.

*Note:* Choosing a background color changes only how the drawing appears on the monitor screen. Because Visual CADD does not print or plot the background, the output is unaffected.

## Selection options

These options control the amount of visual feedback you receive on screen as you draw or edit. Turning these functions off can reduce the time required to edit large selection sets, since highlighting or dragging large groups of objects can take a considerable amount of time on older computers.

**Show Drag** - specifies if selected objects will visibly drag across the screen during move and copy operations.

**Show Highlight** - specifies if selected objects are highlighted in the selection color.

**Quick Search** - determines if Quick Search is toggled on or off. If toggled on, Visual CADD will select the nearest object in the database within the current search tolerance.

**Search Tolerance** - sets the maximum distance in on-screen inches the cursor may be from an object for Visual CADD to snap to it or select it. This value also determines the size of the aperture tool discussed later in this User Guide.

## Display options

These options determine whether certain items are displayed on the screen as well as in output such as printing to paper or to a PDF file. Turning off the display of some of these items while drawing will reduce the visual clutter and increase the speed of redraws (especially true with hatches) on older machines.

**Construction Points, Handle Points, Fills, Hatches, and Points** - specifies if these items are displayed and printed or plotted (checked) or hidden (unchecked).

**Line Type** - specifies whether all linetype patterns are displayed and printed or plotted (checked) or whether all lines appear as line type 0 Solid (unchecked).

**Line Width** - specifies whether all linewidths are displayed and printed or plotted (checked) or whether all lines appear as line width 0 (unchecked).

**Show Scrollbars** - when the box is checked the scrollbars are displayed. You can also toggle the state of the scrollbars by right-clicking on the top menu bar, the top or side toolbars, or on the status bar. If the scrollbars are displayed, you can also turn them off by right clicking on a scrollbar.

## System 2 dialog

Miscellaneous Settings

- Environment Save on Exit
- Shift + Right Button = Popup Menu
- Speedbar East Property

Mouse Wheel Settings

- Enable Zoom In/Out
- Zoom Factor: 1.5 % Multiple
- Reverse the Wheel Direction
- Use Zoom Previous
- Enable Panning
- Pan Factor: 25 % of Screen

Font List Sorting

- Alphabetical
- Vector then TrueType
- TrueType then Vector

Layer Groups

- Save Current Properties with new Group

File Management

- Use File Locking
- Auto Backup every 0.5 minutes
- 3 # of Sequential Backups (1-10)
- Auto Save every 5.0 minutes

OK Cancel Help

Open the System2 dialog from the *Settings* item on the Utilities menu or by typing **TB2**.

The dialog is shown here with the default settings that appear the first time you open Visual CADD.

### Miscellaneous Settings

**Environment Save on Exit** - when checked, the *Save Current Environment* command is automatically run every time you quit Visual CADD. This means that all the settings in the drawing that are current when you close the

application will be applied to any new drawing that you create the next time you open the program. If you have multiple drawings open, the settings from the last drawing that is current when you exit Visual CADD will apply.

Alternatively, if you leave the box unchecked, Visual CADD will not update the environment until you choose to change settings with the *Save Current Environment (EN)* command found on the Utilities menu. Until you do so, the exact same settings will be applied to each new drawing, no matter how many times you open and close Visual CADD.

You should leave the box unchecked if you have a "standard" group of settings that you want to appear each time you begin a new drawing in Visual CADD.

**Shift + Right Button = Popup Menu** - by default, Visual CADD uses the right mouse button to display context sensitive popup menus. By checking this box you free up the right button and can then assign another command or routine to it via *Assign Script*. If you want to use the *Snap Near Point* command, you don't have to assign it

via a script; with the box checked it is automatically assigned and activates any time you click the right mouse button.

Hold down the SHIFT key and right click to bring up a popup menu. Alternately, if you have a three button mouse and don't assign a command to the middle mouse button via a script, that button will activate the popup menus.

**Speedbar Fast Properties** - when checked, certain speedbars display an edit box instead of a dropdown list - the *Properties* and *Change* speedbars for example. This allows you to type information into the box from the keyboard instead of having to use the mouse to dropdown a list. Using the Tab key to move between the boxes and then typing the information directly can greatly speed up your work. If you need to see a dropdown list while in this mode, note that you can toggle Fast Properties "on the fly" by right clicking in the appropriate speedbar after opening it.

## Mouse Wheel Settings

**Enable Zoom In/Out** - checked by default, it allows a mouse with a scroll wheel to zoom in/out in Visual CADD. If you do not want this feature, uncheck the box.

**Zoom Factor** - sets the multiplier used to change the drawing magnification when zooming in or out with the wheel. The default setting is 1.5; the minimum you can set is 1.1 .

**Reverse the Wheel Direction** - the default setting is to roll the wheel forward to zoom out and roll it towards you to zoom in. Checking the box reverses this action.

**Use Zoom Previous** - by default each zoom in and zoom out with the mouse wheel results in a display that is centered on the cursors position in the drawing. When the Zoom Previous box is checked, a zoom out with the wheel will zoom to the previous zoom of the drawing, as long as the drawing has not already been zoomed out by another command. The cursor position is ignored for zoom outs with zoom previous on. When there is no previous zoom available or the drawing has been zoomed out with another command, the resulting zoom out will be centered on the cursor.

**Enable Panning** - checked by default, it allows you to pan with the scroll wheel. Hold down the Shift key to pan sideways or the Control key to pan up or down. If the scrollbars are turned on, you can pan without using the keys by hovering the mouse pointer over the bar and scrolling the wheel.

**Pan Factor** - sets the multiplier for the amount of a pan, as a percentage of 100. For example, a setting of 25 will pan 1/4 of the screen.

## Layers

**Use Layer Properties** - when checked, objects drawn on each layer take on the properties assigned to that layer. Note that in all earlier versions of Visual CADD this setting was found on the *General Settings* dialog. It has been moved to this dialog because it is a global setting that affects all open drawings.

## Font List Sorting

In Visual CADD you can use TrueType fonts, vector fonts, or a combination of both in your drawings. Many people choose to use only vector fonts or TrueType fonts. Because Visual CADD allows both, the dropdown list of fonts can be quite long, and require a lot of scrolling to find the desired font.

You can choose several options for how the font list will appear in each of the VCADD dialogs. Check the appropriate radio button to determine the order that fonts will be displayed in all font dropdowns in Visual CADD. *Alphabetical* displays all fonts in order; *Vector then TrueType* lists vector fonts at the top of the list; and *TrueType then Vector* displays TrueType fonts at the top of the list.

The new Font Manager described later in this Guide gives you additional display options.

## File Management

**Use File Locking** - when checked, subsequently opened drawings cannot be modified by another Visual CADD user on your network until the drawing is saved or closed. Other users can only open, view, and copy the drawing.

**Auto Backup** - when checked, Visual CADD will automatically save your work in a backup file. Visual CADD will not overwrite the current VCD file with new information but will save it with a different file extension (.vbk). When this option is checked, all open, named drawings in all document windows will be saved in the .vbk format at the specified time interval. A drawing that has not been saved can't be backed up. Only drawings that are named and have changes (i.e., entities added, deleted, moved, etc.) will be automatically backed up. Named drawings that you open but make no changes to will not be backed up.

If your .vcd file becomes corrupted or is lost, you can open the backup .vbk file with the *File Open* command. VBK files are opened as Read Only --you cannot modify the drawing and save it as a VBK. Instead use the *Save As* command to save the .vbk as a Visual CADD file in the .vcd format.

**# of Sequential Backups** - by default a single .vbk file is saved when you have Auto Backup turned on, saved at the interval you specify in minutes as described below. But you can specify up to 10 sequential backups. They are saved in the following order: .vbk, .vb1, .vb2, .vb3 etc through .vb9.

**Auto Save** - when checked, all drawings open in the current session will automatically be saved at the interval specified. If you have a new drawing that has not yet been saved, the File Save dialog will appear at the specified interval.

**Minutes** - specifies the interval, in minutes, at which drawings will be automatically saved in the .vcd or .vbk formats when the boxes described above are checked. Visual CADD will not save at the specified interval if a dialog box, such as the Text Editor or

Assign Script is open, or if a tool is active, until the dialog has been closed or the tool operation completed.

## Use Layer Group Properties

When you create a *Layer Group*, you have the option of saving the properties that are current at the time of creation for the layer, color, linetype and linewidth with the Group. If you check this box, those properties will become current properties when you apply the layer group in a drawing. If unchecked, the properties that are now current in your drawing apply to any layer group that you open, regardless of whether other properties were saved at Group creation.

## Advanced Settings Dialog

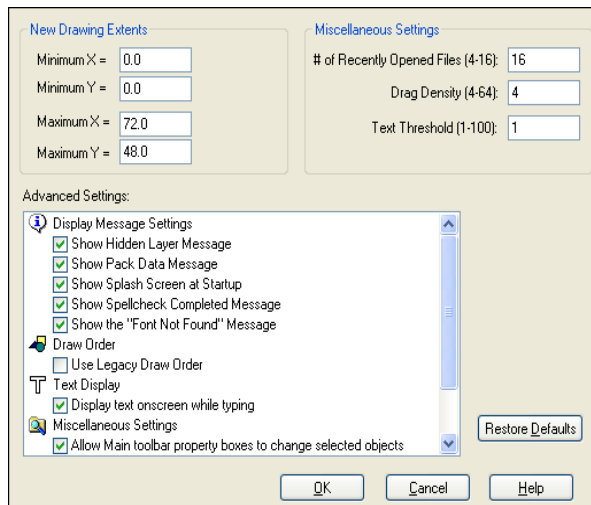

Advanced settings tend to be those that are changed once if at all and then not thought about again.

**New Drawing Extents** - sets the zoom for a new drawing. The initial view will open to a size for the type of drawing you want to create. For example, an architect drawing house plans may start at 72' by 48' or a cabinet maker may start at 3' by 4'. The units in the edit boxes are the Entry and Display Unit as set on the *Numeric* dialog (for example; decimal feet, fractional inches etc).

**Recently Opened Files** - sets the number of recently opened files shown in the list at the bottom of the File menu. Range is 4-16 and the default is 8.

**Drag Density** - sets the onscreen appearance of objects as you drag them. Lower values (in onscreen inches) mean more dots displayed for greater clarity but slower redraw time. Range is 4-64 and the default is 16.

**Text Threshold** - sets the zoom level that text is shown onscreen. This setting has an entry range 0 to 100. Higher numbers will show text as "greeked" (solid line) as you zoom out. Lower numbers will show the individual text characters.

### Advanced Settings List:

*Display Hidden Layer Message* - by default Visual CADD displays a message when you first open a drawing warning if hidden layers exist in the drawing. Uncheck this box and the message will not be displayed.

*Show Pack Data Message* - by default Visual CADD displays a confirmation message when you run the Pack Data command, asking if you are sure you want to perform the operation. Uncheck this box and the message will not be displayed and the Pack Data command will simply execute and complete.

*Show Splash Screen at Startup* - by default the splash screen appears for a few seconds every time you open the Visual CADD program. Uncheck this box and the splash screen will not appear at startup.

*Show Spellcheck Completed Message* - by default Visual CADD displays a message after it parses the drawing for misspelled words, alerting you that it has finished. Uncheck this box and the message will not be displayed.

*Show "Font Not Found" Message* - by default Visual CADD displays this message when you open a drawing that contains a font that is not found on your system. If you share drawings with other users, it is a helpful reminder to obtain the font and install it, so that you are looking at the original drawing exactly as the creator intended. Uncheck the box and the message will not be displayed.

*Use Legacy Draw Order*- checking this box effectively disables the new Draw Order commands introduced in version 5 and returns the display order of objects in the drawing to that used in version 4 and earlier. The old draw order may be used by some 3rd party add-ons, but we recommend most users should keep the new draw order intact.

*Display text onscreen while typing* - by default text and leader characters are drawn onscreen in real time as you type, as well as in the speedbar at top of screen. If you have an older machine or minimal memory, redraw speed may be adversely affected. Uncheck this option and a bounding box (with no text) will expand onscreen as you type characters. The bounding box is default behavior for all versions prior to v5.

*Allow Mainsbar property boxes to change selected objects* - checked by default, when you select one or more objects in the drawing, you can change any or all of the four properties for layer, color, linetype and linewidth by changing the setting in one or more of the property dropdown boxes on the mainsbar. To disable this feature, untick the checkbox.

*Save Auto Backups to subfolder of current drawing's folder* - by default a drawing saved with the Auto Backup option is saved to the same folder as the VCD file that is being backed up. By checking this box, the backup (VBK) file is instead stored in a subfolder of the folder where the VCD is stored. If the folder doesn't exist it is created at the first Auto Backup, and is always named \Backups.

*Tracking always toggles Ortho Mode ON* - the default behavior of the Track command is to always toggle Ortho Mode ON when Track starts, whether or not Ortho Mode was previously ON. If you want Ortho Mode to not change when Track is started, uncheck this box.

**Restore Defaults** - button restores all settings on the Advanced dialog to the default settings when you first installed Visual CADD.

# General Settings

Unlike the system settings, general settings are stored with each individual drawing file. The *current* general settings will be applied to each *new* drawing, but they do not affect previously saved drawings, as explained below.

## General dialog

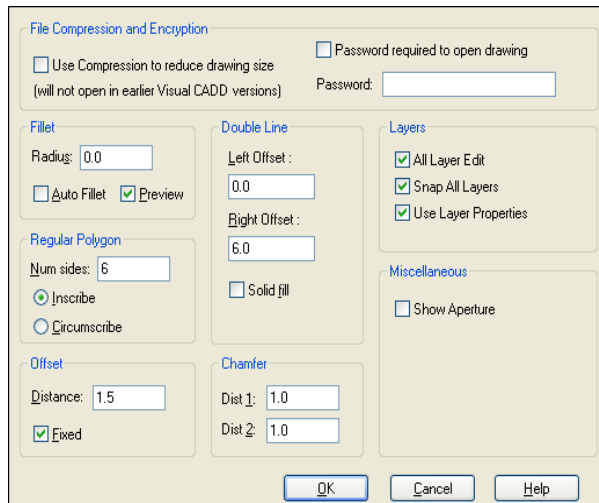

Open the General dialog from the *Settings* item on the Utilities menu or by typing **TBG**.

Settings on this dialog are saved with a specific drawing. For instance, the Double Line Right Offset is set at 6 in the illustration shown here. If you open an existing drawing where the offset is set to 10, it retains that setting unless you change it and save the file with the change. The current offset has no effect on that existing drawing.

However, when you start a *new* blank drawing in Visual CADD,

it will always take on the settings that are current on the General tab.

### Fillet options

These options set the fillet radius either during editing (with the Fillet command), or while drawing with the double-line tool (LD) when the Auto Fillet option is checked.

**Radius** - sets the radius of the fillet.

**Auto Fillet** - specifies if corners are filleted automatically when the Double Line tool is used. The radius occurs at the interior intersection of each inside corner.

**Preview** - specifies if the possible fillet options are displayed as the cursor is moved around an intersection or corner during a Fillet command.

### Regular Polygon options

Settings in this box determine the number of sides and the construction technique used to define regular polygons (i.e., from the Draw menu, Polygon Center and Polygon Side).

**Num sides** - sets the number of sides drawn with the center-polygon and side-polygon tools.

**Inscribe** - specifies if the second point placed with the center-polygon and side-polygon tools will correspond to a vertex of the polygon. This is equivalent to inscribing the polygon in a 2-point circle.

**Circumscribe** - specifies if the second point placed with the center-polygon and side-polygon tools will correspond to the midpoint of a side of the polygon. This is equivalent to circumscribing the polygon around a 2-point circle.

### **Offset options**

Lets you set the distance used by the Offset command, and whether the distance is fixed, or can be changed by using the mouse. The Offset options can also be changed on the speed bar when you are performing an offset.

**Distance** - sets the distance from the target object to the offset copy.

**Fixed** - specifies that the distance is a fixed number as typed in the Distance edit box. If this box is not checked, you can set the distance by placing a point in the drawing area.

### **Double Line options**

This section sets the offset distances used by the double line command, and whether the space between the lines is filled.

**Left Offset** - sets the offset distance of the line to the left of the cursor path.

**Right Offset** - sets the offset distance of the line to the right of the cursor path.

**Solid fill** - specifies if the space between the double lines is to be filled with a solid color.

### **Chamfer options**

These options display the current distance settings used with the Chamfer command. The distances are measured from the corner or intersection of two lines and represent the endpoints of the diagonal line that will chamfer the intersection when that command is chosen.

**Dist 1** - sets the distance from the corner or intersection to the start of the chamfer on the first line selected.

**Dist 2** - sets the distance from the corner or intersection to the start of the chamfer on the second line selected.

### **Layer options**

Lets you control how Visual CADD treats visible layers other than the current layer.

**All Layer Edit** - when checked, you can edit all visible objects, regardless of layer. If unchecked, you can only edit objects on the current layer.

**Snap All Layers** - when checked, you can snap to all visible objects, regardless of layer. If unchecked, you can snap only to objects in the current layer.

### Miscellaneous

**Show Aperture** - when checked it shows the aperture circle as part of the cursor. If unchecked the cursor is displayed as cross-hairs without the circle. The size of the aperture circle is set in the Search Tolerance editbox on the *System1 settings* dialog.

### File Compression and Encryption

**Use Compression to reduce drawing size** - when checked it adds compression when you save the drawing to reduce the size of the file. Please note that using this new feature means that compressed files will only open in Visual CADD 6. Earlier versions do not support and will not be able to open a compressed file.

**Password required to open drawing** - when checked, you are prompted to supply a password when saving the drawing. A second edit box pops up asking you to retype the password. After saving, the drawing cannot be opened without the password. Please note that using this new feature means that password protected files will only open in Visual CADD 6. Earlier versions do not support and will not be able to open a password protected file.

**Password** - the password is case sensitive. A password must be between 1 and 32 characters long. Any character value except zero is valid.

---

**Note** In all earlier versions of Visual CADD the *Use Layer Properties* checkbox was found on this dialog. Because it is a global setting that affects all open drawings, rather than stored with an individual drawing like all other settings on the General dialog, it was moved in version 6 to the *System2 settings* dialog.

---

**Tip** Changes made to the General (and Numeric) dialogs will be saved with an existing drawing when you save that drawing file. These changes will *not* apply to a new drawing that you open in the next session of Visual CADD unless you run the *Save Current Environment (EN)* command to update the environment, or close Visual CADD with the *Environment Save on Exit* box checked on the *System2* dialog.

---

## Numeric Settings

---

Settings on the Numeric dialog relate to the display of numbers in a drawing. There are two distinct settings categories. *Numeric Dimension* settings affect the number

format of dimensions you create. *Numeric Display* settings affect the number format displayed on the status bar and used in direct-distance entry.

Numeric settings are drawing specific and are saved with each drawing. As with the General settings dialog, the current numeric settings will be applied to a *new* drawing you open in Visual CADD.

## Numeric dialog

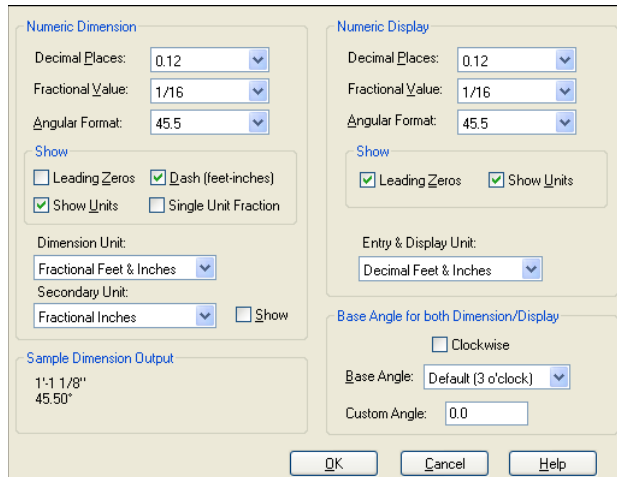

Click on *Settings* in the Utilities menu to open the dialog, then click on Numeric in the settings tree. Settings common to both *Dimension* and *Display* are described first:

**Decimal Places** - sets the number of digits to show to the right of the decimal in both distances and angles. Valid range is 0 to 8.

**Fractional Value** - sets the smallest fractional value permitted in the display when

using a fractional format. The range is 1/2 to 1/64.

**Angular Format** - sets the format for displaying angles as decimal degrees or degree:minutes:seconds. If decimal degrees format is used, the number of decimal places displayed is determined by the Decimal Places setting above. Version 6 adds five new options, including Surveyor, Radians and Grads.

**Leading Zeros** - when checked, total values less than *one* are displayed with a zero preceding the decimal point, or before the fraction if Fractional Units format is on. For example, if Leading Zeros is checked, .75 meters would be displayed as 0.75 m, and 3/4 inch would be displayed as 0 3/4", or 0' 0 3/4" if units are in feet and inches.

**Show Units** - specifies if the abbreviation for the unit type is displayed after the number. Note: If units are Feet and Inches, then units are displayed regardless of this setting.

**Dash** - (dimension only) when checked, displays a dash between feet and inches when dimensions are placed using the feet and inches unit.

**Single Unit Fraction** - (dimension only) determines if fractions will display as single or multiple characters. If checked, fractions within dimensions will display as single units, i.e.,  $\frac{3}{4}$ , rather than 3/4. This setting is only available when using Vector fonts and only with dimensions (not with text or leaders).

**Dimension Unit** - (dimension only) sets the primary unit of measurement in which dimensions are displayed in the drawing.

**Secondary Unit** - (dimension only) sets an optional secondary unit of measurement in which dimensions are displayed in dual units. For example, if you set Dimension Unit to inches and Secondary Unit to Millimeters, placing a dimension will show the millimeter dimension text in parenthesis, directly following the inches dimension text. Tick the *Show* checkbox to display the secondary dimension.

**Entry & Display Unit** - (display only) sets the unit of measurement used in the status bar display, in direct-distance entry, and in certain other dialogs.

**Base Angle** - by default Visual CADD has a coordinate system where 3 o'clock is set as 0 and runs counterclockwise. For example if you start and then draw a line constrained by Ortho Mode to the right, the status bar will report the angle at 0 degrees. If you draw a constrained line toward the top of the screen it will report the angle as 90 degrees.

In version 6 you can change the base angle and save it with a drawing. Status bar prompts will update to show the new coordinates dependent on the base angle you set. For example, if you specify 12 o'clock, and tick the Clockwise check box, you will emulate a compass, with 0 degrees as North and positive values entered clockwise, so that a line drawn to the right will read as 90 degrees.

To use a custom angle, choose the option from the Base Angle dropdown list and type the angle as the number of degrees measured from the 3 o'clock Visual CADD default.

See the Help topic Polar Coordinates for an overview of entering points in Visual CADD.

## ORGANIZING YOUR DRAWING

When drafting with pencil or pen on paper or mylar, complex projects benefit from the use of overlay drafting systems. Different building elements can be separated easily by combining the overlay sheets. For example, you can stack different floor plans -- foundation, first floor, framing, plumbing-- to determine how elements line up with each other. And to prepare a cohesive set of drawings, complex projects sometimes require a large team of drafters, all whom must use the same drawing conventions-- from line weights to symbols to annotation.

The more complex the drawing, the more you benefit by using Visual CADD's organizing tools: Layers, Properties and Styles. Used individually or together, they can speed the setup, editing, redraw, and printing of even the most complex drawings.

Create portions of a drawing on different layers to separate the drawing into logical categories. Use layer groups to display or hide certain layers and to print groups of information separately. Use styles to maintain a consistent format for different types of objects. Styles enable you to change drawing settings quickly and to maintain drawing conventions.

When you develop a scheme for setting up layers and styles before beginning a drawing, you build a foundation for organized, efficient work.

### Using Layers to Manage a Complex Drawing

---

As with the transparent overlays in conventional drafting, you use layers to organize a drawing into distinct categories that can be easily managed as your drawing increases in complexity. For example, you might organize the floor plans for a renovation into the following layers: existing walls, new structure, existing doors, new doors, electrical system, plumbing, mechanical system, and so on. You would then work on each layer, by viewing, drawing, editing, and printing it with any combination of other layers.

The layer functions are available from the Layer Manager. You can draw objects on a layer with any properties you choose, or you can designate that certain properties *always* apply to objects on a particular layer. You can save a single layer or a set of layers as a new drawing to use a portion of the original drawing as the base for a new

project. And in the Settings dialogs on the Utilities menu, you can set dimensions, leaders, text blocks and hatches to always be placed on a specific layer of your choice if so desired, regardless of which layer is set as current in the drawing.

## Layers in a Drawing

You can create an entire drawing on one layer or on as many as 1,024 layers.

S-WALL-DIMS  
E-LITE-CLNG  
P-PPLM  
A-WALL  
A-WALL-EXST  
HIDDEN

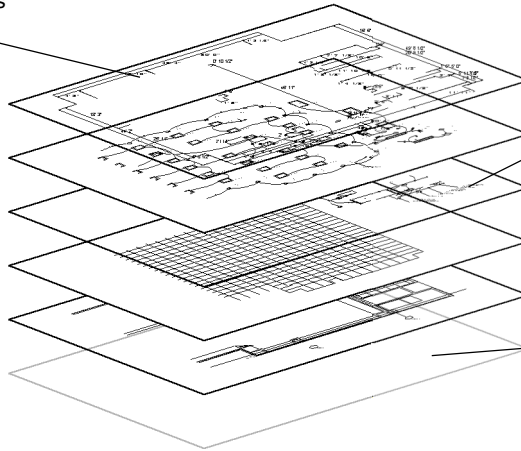

You can move or copy objects from one layer to another. If you copy, the objects on the top layer are shown in front of objects on the original layer. In most cases you will want to select and move one of these to a new location. There are tools available to view and select the original first.

You can hide any or all layers except the current drawing layer. Hidden layers won't print. You can also make a layer visible but non-printable. And you can Lock a layer so the objects on it cannot be selected or edited.

## Working with Layers



Open the Layer Manager by clicking the button on the top toolbar or typing **MGL**. The dialog shows a scrollable list of layers numbered 0-1023. Layers are numbered by default but can be named.

The current layer is shown in the color red. Any layer that has objects drawn on it displays an asterisk (\*). The nine buttons at the top of the dialog perform layer related commands as follows (from left-to-right):

**Visible** - displays or hides the selected layer(s). A hidden layer is shown italicized in the list.

**Lock** - sets the selected layer as locked or unlocked. Objects on a locked layer cannot be selected or edited. A locked layer is shown as underlined in the list.

**Printable** - sets the selected layer(s) as printable or non-printable. A non-printable layer is shown with a horizontal strikethrough line through the number or name.

**Current** - makes the selected layer current.

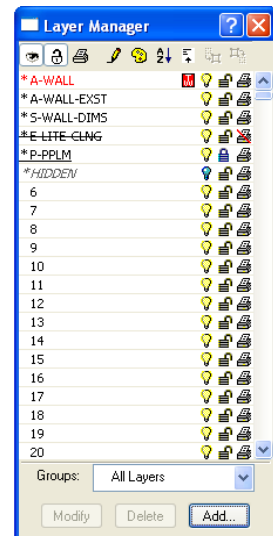

**Set Layer Properties** - opens a speedbar dialog to set bylayer properties as described later in this chapter. Bylayer is an optional feature in Visual CADD.



**Alphabetical Sort** - if layers are named, this toggles their display order between numeric (0-1023) and alphabetical.

**Short List** - toggles the display between all 1024 layers and only those that are named *or* numbered but with objects drawn on them.

**Move** - selected objects in the drawing are moved to the layer you specify.

**Copy** - selected objects in the drawing are copied to the layer you specify.

Note that these commands as well as several others can also be accessed via a popup menu by right-clicking while in the Layer Manager list.

| To...   | Do this in Layer Manager...  |
|---|--|
| Name a layer                                    | Select a layer, press ENTER, type a name and press ENTER again.  |
| Make a layer current so that you can draw on it | Select a layer and click the [Set Current] button or double-click on the layer number/name.  |
| Display a layer                                 | Select one or more hidden layers and click the [Set Visible] button, or click the light bulb icon to the right of a selected layer.  |
| Display all layers                              | Right-click in Layer Manager, click Select All, then click the [Set Visible] button to toggle it on. This same method works to unlock or set printable all layers.   |
| Hide a layer                                    | Select one or more displayed layers and click the [Set Visible] button, or click the light bulb icon to the right of a selected layer.   |
| Hide all but the current layer                  | Right click in Layer Manager, click Select All, then click the [Set Visible] button to toggle it off.  |
| Lock a layer                                    | Select one or more layers and click the [Set Lock] button, or click the lock icon to the right of a selected layer.  |
| Make a layer non-printable                      | Select one or more displayed layers and click the [Set Printable] button to toggle it off or click the print icon to the right of a selected layer.  |
| To move an object to another layer              | Select one or more objects in the drawing. In Layer Manager click on the [Move Selected to Layer] button  , move the arrow over the desired layer in the list and left click. |
| To copy an object to another layer              | Select one or more objects in the drawing. In Layer Manager click on the [Copy Selected to Layer] button  , move the arrow over the desired layer in the list and left click. |

When you copy objects to another layer the new copy will be displayed on top of the other. From the menu, select Zooms>Backward Redraw to display the original on top. Select the objects and move them to another part of the drawing.

Alternately, if you want to move the copied objects to another part of the drawing, hide the original layer, move the object(s), then display the original layer.

Note that the current layer can never be hidden or made non-printable.

You can resize the Layer Manager by selecting any border and dragging the mouse while holding down the left button. You can also “roll up” the dialog by double-clicking on the title bar so that only the title remains visible. This allows you to keep the Manager open while minimizing its impact on screen real estate. When you need to make further layer changes, double click the title bar to roll it down.

Visual CADD offers alternate methods to do some layer management without having to have the Layer Manager dialog open. For instance, from the Layers menu, you can call up speedbars that will let you set the current layer or display and hide layers. See the Help file for a detailed description of the commands on the Layers menu.

## Working with Layer Groups

---

In Layer Manager you can show or hide any combination of layers and then save the settings as a "snapshot" by creating a Layer Group. For example, you might specify that only Windows, Doors, and Wall layers are visible and printable, and then save that combination as a layer group called *Base Plan*. The main toolbar has a drop-down list where you can select the existing layer groups. The same dropdown is found at the bottom of Layer Manager.

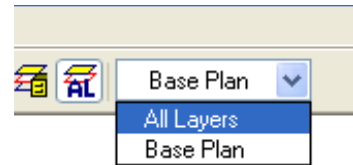

Layer Groups are created and saved with each individual drawing.

Don't confuse layer groups with the Group command found on the Edit menu. A Group is a collection of individual objects, somewhat like a symbol.

### To create a layer group:

1. If the Layer Manager is not open, select Layers>Layer Groups.
2. In the layer list, set the status of each layer as you want it to appear in the layer group. That is, specify which layers you want visible, printable, locked and so on.
3. Click the Add button at the bottom of the dialog.
4. Type a name in the new window that pops up. If you want the group to save the current drawing properties, check the box.
5. Click [OK]. A new group is created and the name is displayed in the Groups list at the bottom of the Layer Manager dialog.
6. If desired you can now change the settings in Layer Manager and then add another layer group.

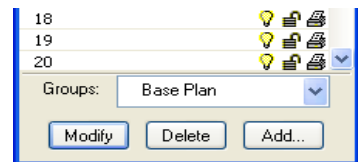

**To modify a layer group:**

1. If the Layer Manager is not open, select Layers>Layer Groups.
2. In the bottom part of the Layer Manager, select the layer group that you want to modify from the dropdown box with the arrow.
3. Make changes to the layer settings in the Layer Manager list.
4. In the Layer Manager, click [Modify].

**To delete a layer group:**

1. If the Layer Manager is not open, select Layers>Layer Groups.
2. In the bottom part of the Layer Manager, select the layer group that you want to delete from the dropdown box with the arrow.
3. In the Layer Manager, click [Delete].

**To apply a layer group in the drawing:**

1. Select a Group from the dropdown on the main toolbar.
2. The drawing updates with the new group.

If you saved the properties for layer, color, linetype and linewidth that were current in the drawing when the group was created, you have the option to either use these settings, or the properties that are current in a drawing when you apply the group.

On Utilities>Settings>System2, checking the box in the Layer Groups section titled *Use Layer Group Properties* will apply the settings originally saved with the group. With the box unchecked, settings in the current drawing will be applied instead. If you did not save current settings when creating a layer group, this setting will have no affect. See the Layer Group topic in the Help file for more detailed information.

---

**Tip** Run the Save Current Environment (**EN**) command from the Utilities menu if you want changes such as the one described above to “stick” next time you open Visual CADD. Otherwise settings will revert to the previous state.

---

## Assigning Properties to a Layer

---

By default Visual CADD draws objects with the properties that are currently set for layer, color, linetype and linewidth. If for instance color red is current and you want a new line with color yellow, you either set the color property to yellow before drawing the line or later modify the line to change the color from red to yellow.

But you can also assign color, linetype and linewidth properties to a particular layer so that all objects you subsequently draw on that layer have those properties applied. Layer Properties can speed your work; to change all of the properties of the object you want to draw, you only need to change the current layer.

Layer Properties are commonly known as *Bylayer* in other CADD programs. Many of these programs are strictly bylayer and force you to set all properties before you draw anything. Visual CADD gives you a choice.

Layer Properties in Visual CADD are flexible, allowing you to use bylayer for one property and the current settings for another. For example, you can assign the color for layer 10 to red and the linetype and width to “none”. When you draw a line on layer 10, it will always be color red, but will take on whatever linetype and linewidth are current in the drawing when the line is drawn.

Layer Properties are applied in the drawing when you mark the *Use Layer Properties* checkbox on the Utilities>Settings>System2 dialog. If you later clear the *Use Layer Properties* option, each object instead takes on the properties that were current in the drawing at the time the object was drawn. This can be confusing; we recommend that if you decide to embrace Layer Properties, you use them consistently on all drawings. The ability to set some or all bylayer settings for each layer, and the option to assign them to any or all layers in a drawing, make Layer Properties a powerful feature.

---

**Tip** To assign layer properties to objects drawn on a layer before properties were assigned to the layer, select the objects, select Modify>Change, and press the [LP] button on the speedbar.

---

## Layer Properties Speedbar



The *Set Layer Properties* command can be started from either a button on the Layer Manager dialog or a selection on the Layers menu. On the speedbar shown above assign color, type and width layer properties to the layer you specify. You can also choose to clear all Properties previously assigned to a layer.

### To assign properties to a layer:

1. In Layer Manager, select a layer (or hold down SHIFT and select a series of layers).
2. From the top of the Layer Manager, click [Set Layer Properties] .
3. In the Layer Properties speedbar, select options from the drop-down lists to set the layer properties, and then click [Apply].

## Using Styles to Maintain Standards

---

A Style is a template; a collection of settings you define, name, and save. You create a style and apply it to a new or existing drawing to set some or all of the drawing’s settings in one step, saving time and maintaining consistency. Loading a style does not

modify existing drawing objects; instead it applies to any further entities created in the drawing.

When you create a style with the Save Style command you are taking a “snapshot” of the current drawing settings. You can choose *all* the current settings, or save a style that might include only the properties of objects, Visual CADD’s drawing environment, selection filters, and file exchange settings or some combination.

## Why Use Styles?

Use styles to maintain project or company drawing standards. For instance, using the same styles, all members of a project team can create drawings that use the same layer conventions, line widths, colors, hatches and fills, and Symbol settings.

Styles are also a quick and easy way to load an entire group of settings for a particular type of object. For instance, create different text and dimension styles and then quickly call them up with the Load Style command.

### To Save a Style:

1. Change the settings in the drawing environment as desired, then click File>Save Style or type **TV**.
2. Click the *Style Settings* button to open the dialog, check the categories that you want to include in the style or click [All] to select all categories, and then click [OK].
3. Enter the name of the style file, and then click Save.

### Information in style categories:

- Some categories define all settings for a single entity type, such as hatches, symbols and text.
- Others define all settings for non-entities, such as Numeric and Fonts settings.

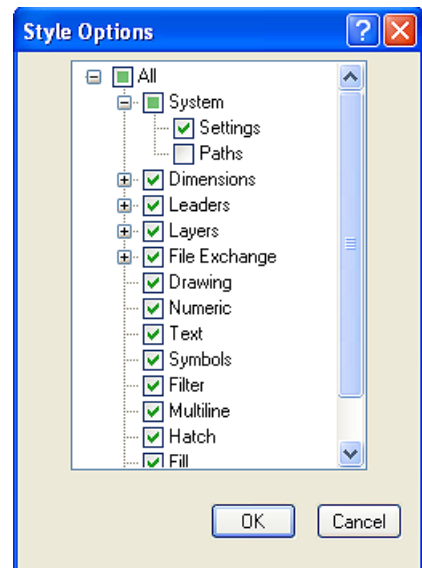
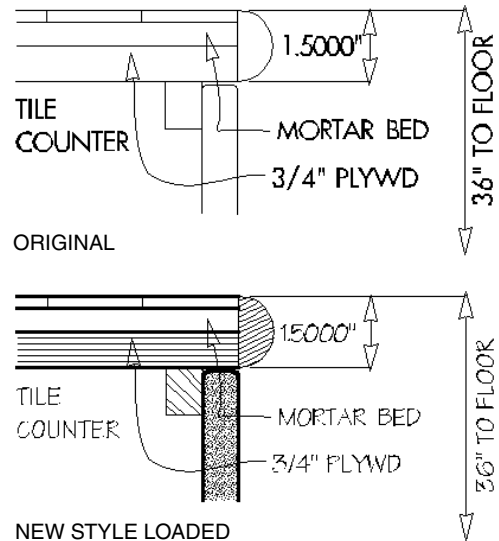

- Some categories give you the option of defining settings in greater detail. For example, on Layers you can choose to save only the current layer settings, only the current layer groups in the drawing, or both.
- Filter includes all the settings on the Selection Filter speedbar.
- Dimensions include the ability to apply only some of the current settings, for example text, arrows and extensions.
- Leaders also give the option of saving only some settings.
- File Exchange can include all Import/Export settings or just DWG or GCD.
- Drawing checkbox includes all settings on the General and Constraint settings dialogs.
- System checkbox includes global settings that apply to all drawings.

**To Load a Style:**

1. Click File>Load Style.
2. Select a style file, and then click [Open].

---

**Note** System settings saved with a Style by default include the file paths as found on the Paths tab of the Utilities>Settings menu. If you are using a Style file in v6 that you will share with others who might have different paths, uncheck the Paths checkbox before saving the style. See the illustration on the preceding page that shows System settings being saved with the style but not the paths.

---

# THE DRAWING TOOLS

In conventional drafting, you lay down lines by drawing each stroke exactly as you want the finished line to look. In CADD, you draw lines (for example, the perimeter of a building), and then delete parts that are unneeded, for example, to make openings for windows and doors.

In CADD, you draw lines and other objects by placing the points that define a drawing entity, such as a line, a circle, or a polygon. Each point is represented by an X,Y coordinate shown on the display and stored in the drawing database.

Visual CADD provides the tools to draw efficiently. Rather than drawing two lines separately to create a wall, for example, use the Double Line tool to lay down two lines at a specified distance from each other.

Each object that you draw has a set of basic properties for layer, color, linetype and linewidth. You can change these settings if desired before starting a drawing tool.

## Introduction to the Drawing Tools

---

To draw objects in Visual CADD, start a drawing tool, and then place the points that define the object by either clicking its position with the mouse or typing in the x,y point coordinates. The status bar prompts you for the next point to enter.

Some tools create a series of adjoining line segments or curves. Others create a closed object, such as a rectangle or polygon. You can choose to draw these closed objects as a single object (also known as a polyline) or exploded so that each line is an individual entity. Most tools create objects that maintain their shape when you move or modify them.

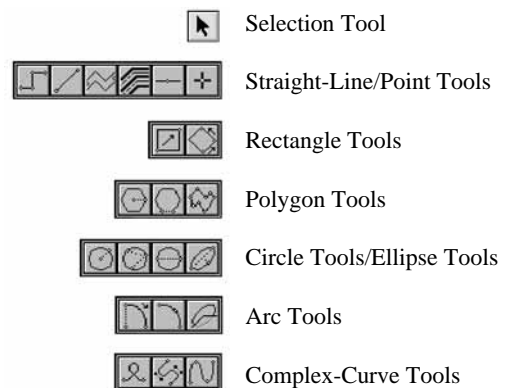

## Methods of entering points

### To draw by entering keyboard coordinates:

1. Select a drawing tool, type X and Y coordinates, separated by a comma, and press ENTER to set the first point.
2. Type in the X and Y coordinates to locate additional points, pressing ENTER to set each point.

### To draw by using direct distance entry:

1. Select a drawing tool, and then either click the mouse or type X and Y coordinates and press ENTER to set the first point.
2. Move the mouse in the direction and at the angle where you want to place the second point, type a distance, then press ENTER.
3. The point will be placed at the distance value you entered. Use the Ortho commands to constrain the point at a precise angle if desired.

### To draw by entering polar coordinates:

1. Select a drawing tool, and then either click the mouse or type X and Y coordinates and press ENTER to set the first point.
2. Type a distance and an angle, separated by the symbol for angle (e.g.; 36<45), and then press ENTER. Note: use this method after setting the Relative coordinate system as described at the end of Chapter 2 to achieve accurate results.

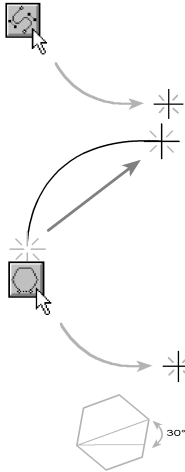

15.30

## Setting Properties

Every object that you draw in Visual CADD has four basic properties: a layer, color, linetype and linewidth. Set these properties before you draw by selecting them from the dropdown boxes on the main toolbar, or with the Properties command on the Draw menu.

**Layer** - by default layers have a number but you can name any layer using the Layer Manager dialog described in Chapter 4.

**Color** - assign any one of 256 colors to an object.

**Linetype** - Visual CADD has 50 default linetypes. See a complete illustrated list in Appendix B. You can modify existing or create new linetypes. See Chapter 13 for details on customizing linetypes.

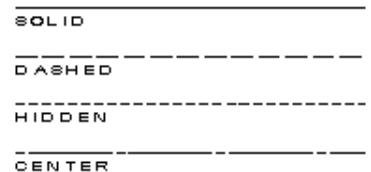
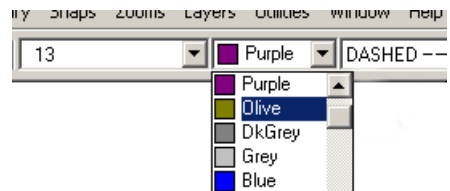

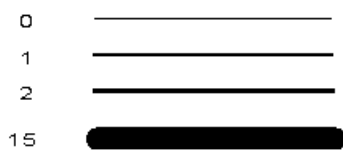

**Linewidth** - There are 16 predefined linewidths that display and print based on pixels; linewidth 2 is 2 pixels and linewidth 15 is 15 pixels. A small sample is shown here; see Appendix B for the full list.

You can also specify a Real-World linewidth by selecting the last entry in the linewidth dropdown on the main toolbar and then typing in a value, or from the Properties command on the Draw menu by clicking the [RW] button and typing in a value. Real-World linewidths print and display at the width you enter, regardless of the drawing scale.

---

**Note** Linewidths 0 and 1 both appear onscreen as 1 pixel.

---

## The Straight Line Tools

---

Visual CADD has five tools for drawing straight lines:



**The Single Line tool (LS)** creates a line between two endpoints A and B.

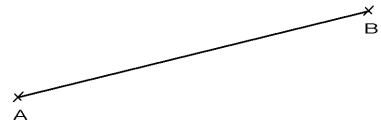

**The Continuous Line tool (LC)** places the endpoints A, B, C, D, and E of adjacent line segments. Use this tool to draw a continuous, segmented line. When you select a segment of a continuous line, you select the entire line, unless you set Visual CADD to explode continuous lines on placement.

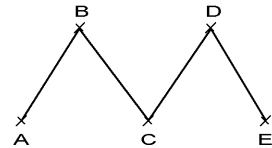

Continuous Line is one of five persistent or “continuous” drawing tools, active until you either double click, press ESC, or right click and select *Pen Up* from the popup menu. You can also type **PU** to run Pen Up and end a persistent tool.



**The Midline tool (ML)** places the midpoint A and one endpoint B. Use this tool when you need to draw the endpoints of a single line segment equidistant from a specific point.

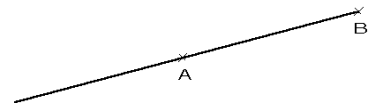

**The Double Line Tool (LD)**, a continuous tool, places the endpoints A, B, C, and D of the adjacent line segments of two parallel lines. Use this tool to draw walls and roads. You can set the offset or size of the space between the lines, and you can add a solid fill to the space between the lines.

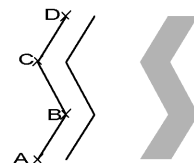

## Setting the offset of double lines:

The **line offset** specifies the distance from the cursor to each line drawn with the Double Line tool. An offset of 0 locates the line on the cursor. When left and right offset values are equal, the cursor lies equidistant between the two lines. Left and right offsets are defined relative to the cursor's forward movement.

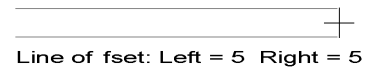
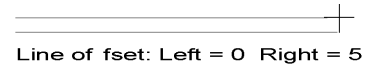

## To change the offset of a double line and apply a solid fill:

1. Start the Double Line tool.
2. Right-click, and then select DB Line Settings (or type **DB**).
3. On the speed bar, enter values in the Left and Right Line Offset boxes, check the Solid Fill checkbox, and then click [OK] or press ENTER.



The **MultiLine tool (MN)**, a continuous tool, works a bit like Double Line but allows you to draw from 1 to 16 separate lines at the same time. Each line can be set with its own dedicated layer, color, linetype and linewidth. Or you can specify that some or all the properties for each line take on the settings that are current in the drawing when placing the line. You can create and save MultiLine Styles and call them up later. Using the MultiLine tool can save a lot of time over the course of a drawing session or project.

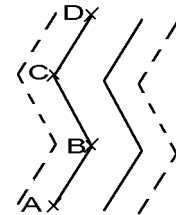

## Setting up a MultiLine Style

To set up a Style, open the MultiSettings dialog from the Draw>Line menu, or type **MS** from the keyboard.

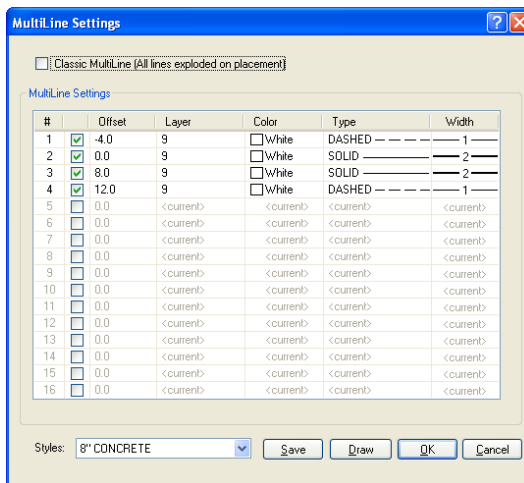

Instead of creating a series of individual lines, you quickly draw entire assemblies. For instance, you could create a MultiLine Style for a wall assembly on a Plan drawing that includes lines to delineate the framing, the interior finish, the exterior sheathing, and the exterior finish. Draw the entire wall at once with the MultiLine command, and then add a hatch to complete the assembly.

In VCADD 6 you can save as many MultiLine styles as you want. Create your style settings, press [Save], type a style name in the dialog that pops up

and type [OK] to save the style and exit the popup. You can click [Save] to create another style without leaving the MultiLine settings dialog, [Draw] to start the MultiLine command using the style current in the Styles dropdown to the left of the buttons, or [OK] to finish and close the dialog without drawing a line.

Visual CADD 6 introduces MultiLine as a true entity type rather than as a collection of single lines. Selecting it after placement selects the entire MultiLine. If you prefer the older method tick the *classic* checkbox on the dialog when saving a style.

The style example shown on the preceding page is an 8” thick concrete wall with 16” wide footings, so they extend 4” from each side of the wall. All 4 lines are placed on the same layer with the same color. The wall lines (#2 and #3) are solid and a heavier linewidth; the footing lines (#0 and #4) are dashed with a lighter width.

If you draw a horizontal MultiLine, the cursor will attach to the line #2 with the 0 value; line #1 will be offset above because the value is entered as -4. Line #3 is offset 8” below line #2, and line #4 is 12” (and thus 4” below the foundation wall line #3).

You don’t have to apply specific property settings for layer, color, linetype or linewidth of a line that is part of a MultiLine Style. Select [current] for any of the properties dropdown lists, and when you draw the MultiLine the properties that are current in the drawing will be applied to that property of the MultiLine.

## The Rectangle Tools

---

There are two different commands for drawing rectangles. By default the rectangle tools draw a single entity that is a closed, continuous line (polyline). However, you can specify that they be placed as individual line segments with the Explode Continuous Lines (**CX**) command on *System1* of the Utilities>Settings menu.



The **2-Point Rectangle (R2)** tool places two points to establish the rectangle’s opposite corners A and B. Points are always placed restricted to 0, 90, 180 and 270 degrees, regardless of the Ortho Angle setting.

Use this tool to create horizontal and vertical rectangles.

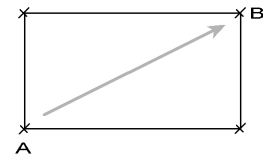

The **3-Point Rectangle (R3)** tool places the two endpoints of the rectangle’s sides A and B, establishing the length and angle, and then places the third point C to establish the rectangle’s height. Use this tool to create rectangles at angles and orientations other than the 0 and 90 constraints, or when you need to specify precise values for both the x and y axis.

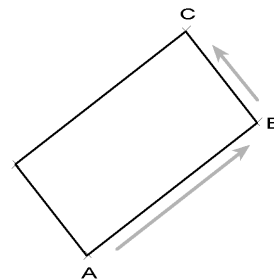

# The Polygon Tools

---

By default, the polygon tools draw a single entity that is a closed, continuous line (polyline). However, you can specify that they be placed as individual line segments with the Explode Continuous Lines (**CX**) setting. Both the Center and Side Polygon tools can draw polygons with up to 99 sides. Set the number of sides after selecting the tool by right clicking and then selecting *Number of Sides*.

The Center Polygon tool draws polygons either inscribed or circumscribed on a circle. To set an inscribed polygon, click the Center Polygon tool, right click, and then select Inscribed. To set a circumscribed polygon, click the tool, right click, and then make sure Inscribed is clear.



**The Center Polygon tool (PC)** places the center point A and, if inscribed, one vertex point on the polygon's perimeter B, or if not inscribed, one midpoint of a side of the polygon C. Use this tool to snap a vertex or midpoint of a side to an existing point.

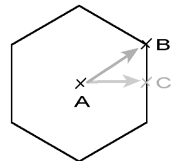

**The Side Polygon tool (PS)** places two adjacent vertices on the polygon's perimeter A and B, defining one of its sides, and then establishes the polygon's orientation C. Use this tool to snap the side of a polygon to an existing line.

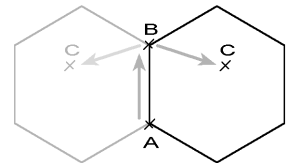

**The Irregular Polygon tool (IP)**, a continuous tool, places points that create an irregular shape with three or more sides of any length or angle. Use this tool to draw an irregular, closed object.

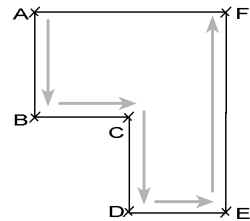

# The Circle and Ellipse Tools

---

Each of these tools draws a single entity that also is a closed object.



**The 2-Point Circle tool (C2)** places the center-point A and one point on the circle's circumference B. Use this tool when you know the location of the circle's centerpoint and any point on its circumference.

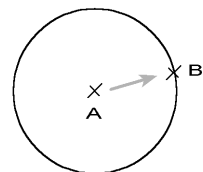



**The 3-Point Circle tool (C3)** places three points on the circle's circumference A, B, and C. Use this tool when you don't know the center or radius, but you know the location of two or three points through which the circle's circumference must pass.

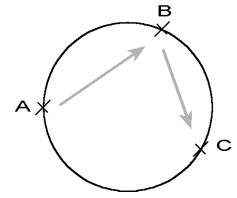

**The Diameter Circle tool (CD)** places points opposite one another on the circle's circumference A and B. Use this tool when you need a circle to exactly fill the space between two objects.

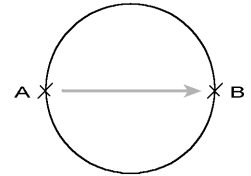

**The Ellipse tool (EP)** places the endpoints A and B of the ellipse's major axis, and then a point at the end of the ellipse's minor axis C.

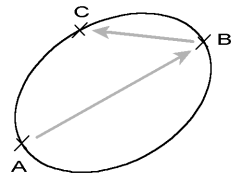

**Tip** Have Visual CADD calculate the distance for you when placing a circle's second point with the 2-point or diameter circle tools by entering a mathematical expression for the radius (diameter/2) or the diameter (radius\*2) in a direct-distance entry.

## The Arc Tools



**The 2-Point Arc tool (A2)** places the centerpoint A of the circle describing the arc, the arc's starting point B, and then the arc's endpoint C. Use this tool to draw an arc with a precise centerpoint or radius, such as a door swing.

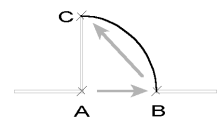

**The 3-Point Arc tool (A3)** places the arc's starting point A, an intermediate point B, and the endpoint C. Use this tool for shaping an arc as you draw it

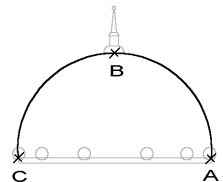

**The Elliptical Arc tool (EA)** first establishes the ellipse that describes the arc, placing the ellipse's first and second endpoints A and B on the major axis of an ellipse, and a point C at the end of the ellipse's minor axis. It then places the arc's starting point D and finally its endpoint E. Use this tool to draw an arc that follows the contours of an ellipse.

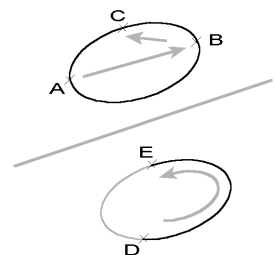

# The Complex Curve Tools

---



**The Single Bézier Curve tool (BS)** places the endpoints A and B of the curve, and then the control points C and D that define the slope of the curve. Use this tool to draw a single Bézier curve.

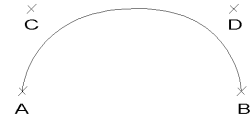

**The Continuous Bézier Curve tool (BC)**, a continuous tool, places the starting point A and subsequent tangent points B, C, and D of adjoining Bézier curves. When you select any portion of a continuous Bézier curve, you select the entire line. Use this tool for drawing steep curves such as highway acceleration curves.

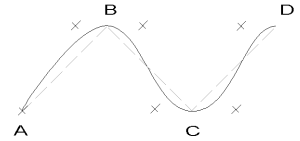

**The Spline Curve tool (CV)**, a continuous tool, places the starting point A and subsequent tangent points B, C, and D of adjoining spline curves. When you select any portion of a spline curve, you select the entire line. Use this tool for drawing the broad curves common to aerodynamics, automotive, and marine design.

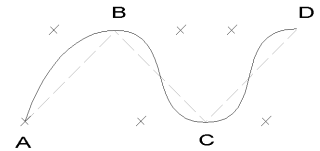

## Point Basics

---

In Visual CADD, points are placed when you draw an entity. An object's first and last points are its endpoints. On open objects, endpoints don't touch. On closed objects, the endpoints touch.

Of the four point types, three are always associated with an object when you place it in the drawing. You can snap to these points or use them to modify the object with commands such as Move or Stretch. *Standard Points* are different: they are an actual Visual CADD entity, independent and not part of another object.

You turn the display of each point type on and off individually from the Utilities>Settings *System1* dialog. There are also keyboard shortcuts to toggle each point type on and off. See the Help file for more information.

## Comparing the Four Types of Points

---



**Standard points (PO)** are the points you place with the Point tool, typically marking positions that are not part of any objects. You can snap to standard points when drawing other objects. Unlike other points, standard points are a unique Visual CADD entity and not part of other objects. They can be printed and can be assigned properties such as layer or color, in the same way as a line or circle.

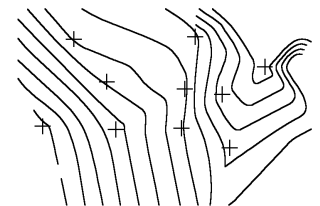

**Construction points** are the points you place to draw objects or to move when editing most objects. The endpoints of lines and arcs and the centerpoints of circles, arcs, and polygons are construction points.

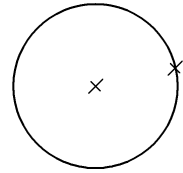

**Control points**, a special kind of construction point, are the points created when placing points and the endpoints of Bézier and spline curves. Defining a tangent to and lying off of the curve, control points alter the curve's size and shape when you use the Stretch command.



**Handle points** are points used to locate certain types of entities, including symbols, text blocks, dimensions, hatches and layers. You typically use handle points to snap to during a Move or other Modify command with these types of objects.

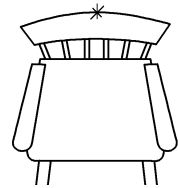

## Using Control Points to Change a Curve's Shape

---

Moving, extending, or retracting control points alters the curve of the adjacent line segments. With construction points checked in the Display section of the Settings *System1* dialog, you can see the control points displayed on a selected Bézier or Spline curve, and select them to modify the curve shape.

### How Control Points Shape a Curve

---

A control point controls the portion of the curve on the same side of the construction point.

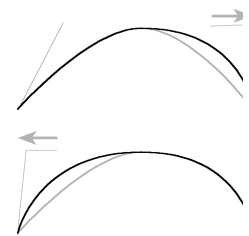

As you drag a control point farther from its corresponding construction point, the curve becomes broader.

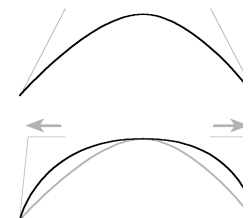

### To alter a complex curve by moving a control point:

1. Select Modify>Move Point, and then click the control point on the curve you want to reshape.

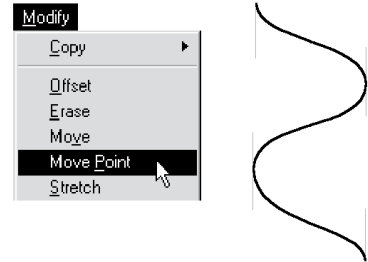

2. Drag the control point to its new position.

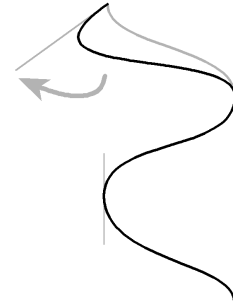

---

**Tip** To turn off the display of control points so that you don't accidentally snap to or alter the shape of a curve, type **DV**, select Zooms>Redraw. Type **DV** again to display them.

---

## Properties

---

The Properties command sets new current drawing properties for linewidth, color, layer, and linetype. After the properties have been set, the next entity you create will be drawn with the new properties.

In earlier Visual CADD versions, a properties button was on the main toolbar, and clicking on it opened the command. Now you can set the 4 properties directly from dropdown list boxes on the main toolbar, as described in the beginning of this chapter.

Why use the Properties command if you can make the same changes from the toolbar? You might prefer it simply because you are used to it from past versions. Or you might want to use the Fast Properties feature, which is not available on the main toolbar.

### Properties Speedbar

---

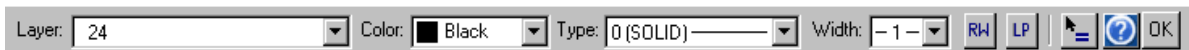

Start the Properties command from the Draw menu or by typing **PP**. Using this speedbar you can:

- Change any or all of the 4 properties by selecting from the dropdown lists.
- Press the [RW] button and type a value in the Width box to set a Real-World linewidth.
- Press the [LP] button to return the settings to Layer Properties. If you have assigned layer properties to a layer, it is possible to override them by selecting a different property, either in the Properties dialog or on the main toolbar. Clicking [LP] returns the settings to the ones assigned by the *Set Layer Properties* command.
- Press the Match button to set all 4 properties to match an object already in the drawing. After pressing the button, click on the object in the drawing with the properties you want to match. The settings of the selected object are applied and the Properties speedbar immediately closes.

## Fast Properties

---

This powerful feature allows you to use the speedbars as a command line, entering values directly from the keyboard without having to move the mouse up into the speedbar and pick from dropdown lists. When toggled on it works with several commands, including *Properties*, *Change*, *Selection Filter* and *Set Layer Properties*. The dropdown lists on these speedbars are replaced by edit boxes where you type in a value to set the property.

To turn it on, right click on the speedbar of any of the commands above and click on *Fast Properties*. You can also set Fast Properties on the System2 dialog of the Utilities>Settings menu or by typing the 2 letter keyboard shortcut **FP**.

### To set properties with Fast Properties:

1. Start the Properties command and make sure Fast Properties is toggled on.
2. The value in the Layer edit box should be highlighted. Type in a new value to replace it if desired.
3. Press the Tab key to move to other edit boxes, and type in new values as needed.
4. Press ENTER on the keyboard to end the command.

## Line Scaling

---

You can set or change the scale of all non-solid linetypes in a drawing with the Line Scale command. This is useful if you print the same information at different scales and want more control over the appearance of linetypes in your output. The command affects all non-solid lines in a drawing; it cannot be applied to only one line at a time.

If you save a drawing with a new Line Scale it affects only that drawing; it is not a global setting.

There are two types of linetypes in Visual CADD: Device and World. With the Device type the apparent size of the segment lengths will remain constant onscreen and on paper regardless of the zoom factor or print scale. With the World type, the apparent size of the segment lengths will change when you zoom in or out onscreen, or when you plot or print at different scales.

### To change the line scale in a drawing:

1. Select Draw>LineScale from the menu or type **LZ**.

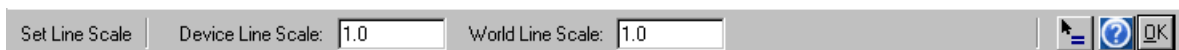

2. In the speedbar, type the desired linescale into either or both the Device and World Line Scale edit boxes. The default is 1.
3. Press [OK] to end the command. All non-solid linetypes in the drawing will immediately be redrawn at the new scale.

---

**Tip** All the linetypes supplied with Visual CADD are of the Device type; changing the World Line Scale has no effect on lines in your drawing. If you want to add World linetypes, see the topic *Customizing Linetypes* in the Visual CADD 6 Help file.

---

## Isometric Mode

---

Isometric Mode constrains the line tools to angles of 60 and 90 degrees to create the left side, right side, and top of an isometric drawing. It is useful for drawing details where a flat 2D projection might not convey the needed drawing information, for example the timber connections shown in the illustration below.

Isometric Mode also changes the cursor to reflect that you can draw only at these angles. The onscreen display of the cursor will change depending on which option is active in Isometric Mode. For instance, with the Iso-Top (**IO**) option active, the cursor will appear onscreen as an "X" and you are constrained to drawing lines at 120° either direction. Iso-Left (**IL**) and Iso-Right (**IR**) constrain the lines to vertical and 60° in either direction.

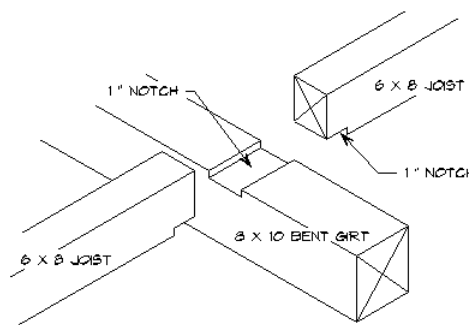

The Isometric Mode command (**IM**) on the Draw menu toggles Isometric Mode on and off and changes the cursor display when you start a line tool.

# DRAWING WITH PRECISION

Visual CADD replaces parallel rules, T-squares, triangles, and other manual drafting equipment with more precise tools such as Ortho settings, Snaps, and Grids.

Ortho mode constrains all entities that you draw to  $90^\circ$  increments of a specified base angle, ensuring square corners and true horizontals and verticals.

When you use snaps, you don't need to know the precise location of a point you want to place. Instead, you define the relationship of the point to a point on an existing object. The new point snaps to the existing point.

When you draw on a grid, you can snap points to the intersection of gridlines, ensuring that you place the points at regular intervals.

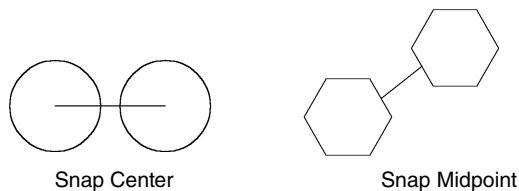
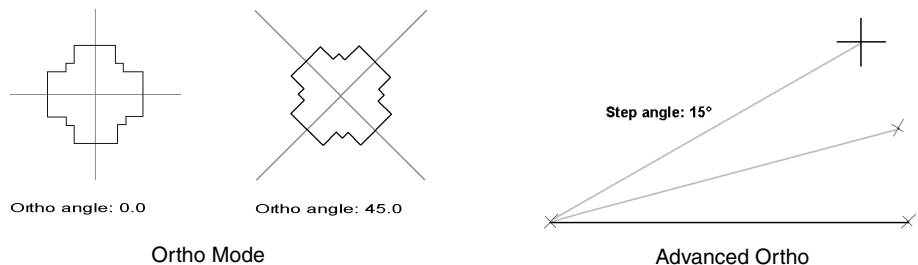

Snap Grid

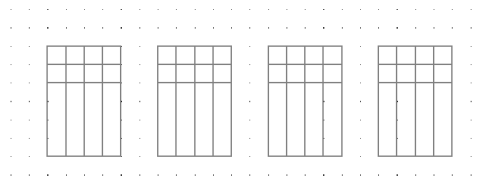

# Constraint Settings

---

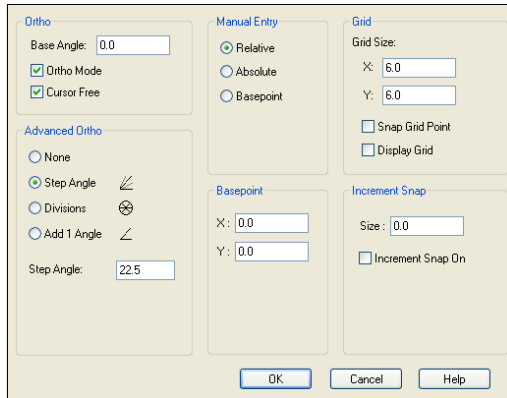

Open the Utilities>Settings>Constraint dialog to initially set ortho and grid properties. Individual settings are discussed in more detail later in the chapter. In addition, the Help file gives a complete description of each setting on the dialog.

•The Ortho section is where you set the base ortho angle, toggle whether ortho is constrained to 90 degree directions, and if desired set the cursor to move independent of the object you are drawing when Ortho Mode is on.

- Advanced Ortho settings allow you to draw using additional angles while drawing with ortho constrained.
- The Manual Entry section sets the coordinate entry mode as described in Chapter 2. If you set the mode to Basepoint, specify the X and Y coordinates in the edit boxes of the Basepoint section.
- The Grid section sets the size of the grid, whether it displays, and whether to snap to the grid points.
- Increment Snap is a special snap, as described below, that you might use when placing objects of the same length or same offset from each other.

## To draw in multiples of a specific length:

1. Select Utilities>Settings.
2. In the tree list at left side of the dialog click [Constraint].
3. Tick the *Increment Snap On* checkbox, and type a value in the Size box.
4. Click [OK] to close the dialog, then start a Draw or Modify tool.

---

**Tip** To quickly place joists or rafters on a framing plan, set Increment Snap to 16 or 24 inches and use the Multiple Copy command.

---

# Constraining Lines and Objects

---

In ortho mode, you constrain all points that are placed to a perfect 90° relationship with each other. You can toggle ortho mode on or off for one point, a series of points, or all points in your drawing. Using the Advanced Ortho options, you can add other angles to the constraint.

Even when ortho mode is on, you can unlock the cursor from its constraint by right clicking the mouse during a drawing command and making sure that Cursor Free is checked (or type **CF** from the keyboard). With Cursor Free on, you can snap to any point in the drawing, and Visual CADD places the closest point that is perpendicular to the cursor location on the constrained axis.

You can also set the Base angle, which changes the Ortho mode base orientation to the angle of the X axis relative to 0°.

## How Ortho Mode Constrains Entities

---

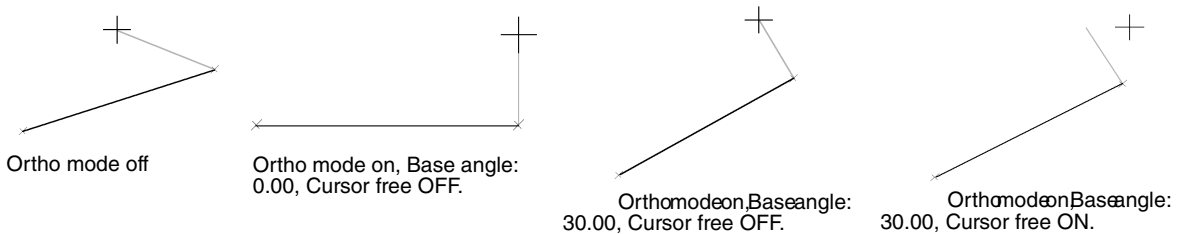

Ortho mode overrides all snaps except the constraining snaps: that is, points you place will constrain to the ortho axes even when you snap them to points not on the ortho axes. If you manually enter the point's coordinates, however, ortho mode is overridden, and the points are placed at the coordinates you enter.

**Tips** Toggle ortho mode On/Off temporarily by holding down CTRL key as you place a point.

Set the ortho base angle to align with an object in your drawing by starting the Ortho Angle command from the Snaps menu (or type **OA**), click the [Match] button on the speedbar, click the object in the drawing you want to align the ortho angle to, and press [OK] or ENTER to finish.

### To turn ortho mode on and off:

Select Snaps>Ortho Mode from the menu. Ortho has a checkmark when on; *or*

Start a drawing tool, right click, and select Ortho Mode. Ortho has a checkmark when on; *or*

Click the Ortho section of the status bar to toggle Ortho on and off. If on, the current Ortho Angle is displayed.

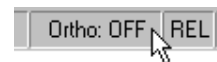

### To change the Base ortho angle:

1. Start a tool, right click and then select Ortho Angle.

2. Enter a value in the Base angle edit box and click [OK] or press ENTER.



## Advanced Ortho

---

By default Advanced Ortho is set to None, meaning that it is not active. With Ortho mode On and Advanced Ortho active, you have three different options to draw additional angles besides the standard 90° degree horizontal and vertical constraints:

- **Step Angle** sets a repeating angle at whatever increment you type in the edit box. For example, setting a step angle of 15° with a Base Angle of 0° lets you draw lines at 15°, 30°, 45°, 60°, 75° etc. all the way around a 360° compass rose.
- **Divisions** divides the compass rose into the particular number of segments you designate. For example, with base angle set at 0, six increments gives you right and left horizontal lines at 0° and 180°, and angled lines at 60°, 120°, 240° and 300°.
- **Add 1 Angle** specifies a single angle in addition to the standard 90° increments. But it actually gives you a total of 4 angles: the one you specify, a mirror to the right, and mirrors up and down. This option is useful for drawing roof elevations and sections, and isometric drawings at non-standard angles.

### To set the advanced ortho angle:

1. Select Advanced Ortho from the Snaps menu or by typing **OV** from the keyboard.
2. On the speedbar, select the desired option, and type the value in the edit box.
3. Select [OK] or type ENTER.



**Note** When you draw with Advanced Ortho active, if you have Cursor Free (**CF**) turned On, you can only change angles within the Search Tolerance (set on the *System1* dialog) after you place the first point of a drawing tool. To see the search tolerance type **AP** to toggle the Aperture, which places a circle around the cursor crosshairs that reflects the current search tolerance setting.

To change the angle at any time during a line command, toggle Cursor Free Off. Or with Cursor Free On, you can press the CTRL key to temporarily turn Ortho off, and then move the cursor roughly to the angle you want, and release the CTRL key. The line will “snap” to the closest angle you have set on the *Advanced Ortho* speedbar.

---

# Working with a Grid

---

When you are creating a drawing with entities spaced at regular intervals, such as a buildings structural system or an electronic circuit board, a grid can speed your drawing while maintaining precision. In Visual CADD, a grid is a nonprinting background of equally spaced dots. A grid enables you to snap the points you are drawing to grid points.

After you activate the grid, you can choose to display the grid or not. You can also change the distance between adjacent grid points.

By default, the grid aligns with the drawing origin's 0,0 location. You can move the grid, however, so that it aligns precisely with a specific point in your drawing

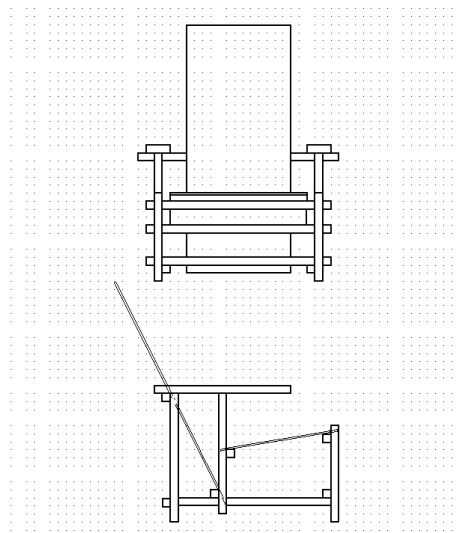

## Using a Grid

---

| To...                                | Do this...  |
|--------------------------------------|---|
| View the grid                        | Select Snaps>Grid>Grid Display.   |
| Snap to grid points                  | Select Snaps>Grid>Snap Grid. When checked, point placement is constrained to the grid points.   |
| Set the distance between grid points | Select Snaps>Grid>Grid Size, and enter the X and Y grid intervals on the speedbar. Click [OK] or ENTER to finish.   |
| Align the grid with a specific point | Select Snaps>Grid>Grid Origin and either type in x,y coordinates or click the mouse to place the origin. Use snap commands to precisely place the origin to an existing point or object in the drawing. |

**Tips** Several actions and commands override the Snap Grid command: manually entering x and y coordinates to place a point, and the snap commands.

You can also start the grid commands from the main toolbar. Display Grid is the default icon. Press it repeatedly and the grid display will toggle on and off. If you hold the left button down over the icon, a “flyout” will appear. Drag the mouse down to select another icon and release the mouse button to start that command.

---

# Drawing Objects Precisely with Snaps

---

Snaps help you place points and objects precisely in relationship to other points, lines, and objects. Some snaps also serve as a drawing constraint. Used in combination with Tracking, snaps can serve as a navigational tool for quickly finding points. You can use a snap any time you use a drawing tool or Tracking, and you can use a combination of snaps together. Tracking is discussed later in this chapter.

You can choose most snaps from the Snaps menu, from the toolbar, or by right click and then selecting Snaps. You can also type a keyboard shortcut for any of the snaps.

## Snaps that Prompt You to Select a Point or an Object

---



**The Snap Object tool (SO)** finds the point on an object nearest where you click.

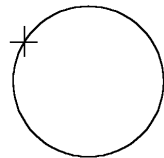

**The Snap Midpoint tool (SM)** finds the midpoint of the line or arc you select.



**The Snap Center tool (SN)** finds the center of an arc, circle, ellipse, or polygon that you click.

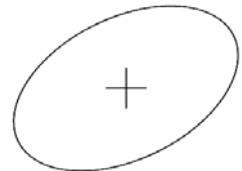

**The Snap Closest tool (SC)** finds the construction point nearest where you click.

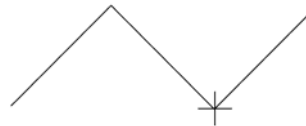

**The Snap Intersection tool (SI)** finds the point nearest where you click at which two entities or objects intersect.

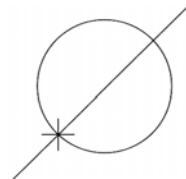

**The Snap Between 2 Points (S2)** tool finds the midpoint between two points or entities that you select.

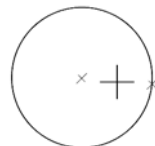



**The Snap Quadrant tool (SQ)** finds the quadrant point nearest where you click on a circle, ellipse, or an elliptical arc. Quadrant positions are absolute, whatever the ortho angle, and correspond to a clock's 12:00, 3:00, 6:00, or 9:00 positions.

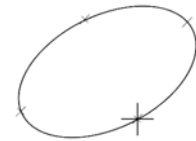

**The Snap Percentage tool (SR)** finds the point at a distance from the end nearest where you click that is a percentage of the entity's total length that you specify. Use snap percentage with lines, arcs, and curves.

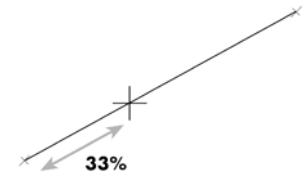

### To draw using a prompting snap:

1. With a tool selected, click the Snaps menu and then click the snap you want, or click the snap tool that you want on the left toolbar.
2. Click the point or entities to which you want to snap, and then continue drawing.

## Quick Snaps

---

**The Snap Near Point command (NP)** is the most commonly used snap command in Visual CADD. It finds the construction point nearest the cursor location when the command is chosen with the right mouse button or keyboard shortcut **NP**.

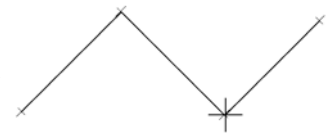

Because the snap is executed immediately with no prompts, and since the cursor must be positioned near the point to be placed, you can't select this command from a menu or toolbar button (and you won't find it on a menu or button). Run the snap with the two-letter shortcut shown above, or by holding down the Shift key and pressing the right mouse button (or, if configured as detailed below, by simply clicking the right mouse button).

**Tip** By default a right click in Visual CADD brings up a popup menu with commands and settings related to the tool currently running. You can specify that a right click runs **NP** instead. On the *System2* dialog of Utilities>Settings, tick the SHIFT+RBUTTON POPUP MENU checkbox. Click [OK] to finish, and run the *Save Current Environment* command (**EN**) from the Utilities menu to make the change "stick" in the next session of Visual CADD. Now your middle mouse button will bring up the popup menu.

---



**The Snap Last tool (LP)** finds the last point placed.

### To draw using a quick snap:

1. With a tool selected, type the two letter command for the snap you want to use.
2. Continue drawing.

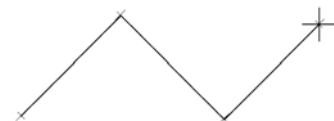

# The Constraining Snaps



**The Snap Perpendicular tool (SP)** sets a line or rectangle you are drawing to be perpendicular to another line, arc, curve, circle, rectangle, polygon, or ellipse.

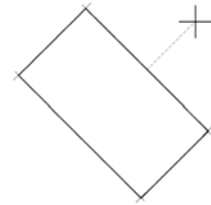

**The Snap Tangent tool (ST)** sets a line or rectangle you are drawing to be tangent to another line, arc, curve, circle, rectangle, polygon, or ellipse.

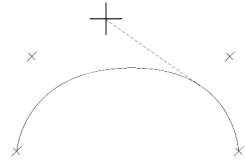

**The Snap Parallel tool (LL)** sets a line, rectangle, or polygon you are drawing to be parallel to another line, rectangle, or polygon.

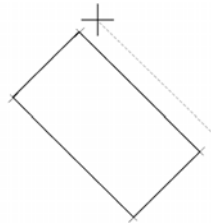

## To draw a line perpendicular to an object:

1. With a tool selected, click the Snap Perpendicular tool.



2. Click the entity you want to snap to, and then continue to draw.

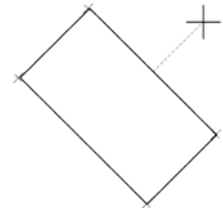

## To draw a line tangent to an object:

1. With a tool selected, click the Snap Tangent tool.



2. Click the entity you want to snap to, and then continue to draw.

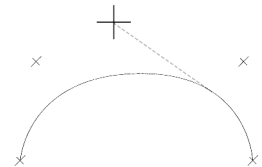

### To draw a line parallel to an object:

1. Start one of the line tools or the 3 Point Rectangle tool, and place the first point of the new line.
2. From the Snaps menu, click *Parallel* or type **LL** from the keyboard to start the Snap Parallel command.
3. Click anywhere on the object that you want to draw parallel to.
4. Drag your cursor to extend the new line, and it will draw parallel to the line that you selected in the step above.
5. Click to set the second point of the new line.

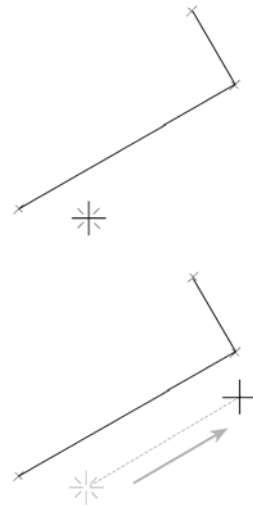

### To draw a line parallel to an object at a specific distance:

1. Start a line tool, but do not set the first point.
2. From the Snaps menu, click *Parallel* or type **LL** from the keyboard to start the Snap Parallel command.
3. Click anywhere on the object that you want to draw parallel to.
4. Enter an offset value on the snap parallel speedbar and then click [OK] or ENTER from the keyboard.
5. Place a starting point for the new line.
6. Drag your cursor to extend the new line parallel to the one selected in Step 3, and place a second point to finish.

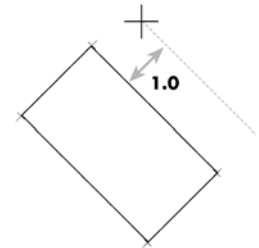
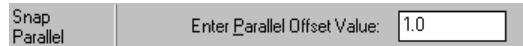

## Running Snaps

If you use one or more Snap tools frequently, you can set these snap tools as running snaps so that you don't have to select the same snap commands repeatedly. Running Snaps remain active until you turn them off in the Running Snaps dialog (or by using the keyboard shortcut **RS**. Type the shortcut again to quickly toggle running snaps on).

If you select the *Preview Snap* options, when the cursor moves within range of a point where a running snap is active, the icon for that snap is displayed beside the cursor, and the object you are snapping to is displayed in a color that you have set from the dropdown list on the Running Snaps dialog.

### To display the Running Snaps dialog:

1. Select Snaps>Running Snaps or type **RN**.
2. In the Running Snaps dialog, select the check boxes for the snaps that you want to set as running snaps.
3. To activate the selected running snaps, tick the *RN Snaps On* checkbox. You can also toggle Running Snaps on and off by typing the keyboard shortcut **RS**.
4. Select the *Show Preview* checkbox to have a snap icon displayed and the object shown in color when the cursor is within range of a snap point. Choose a color from the dropdown list.
5. The *Show Aperture* check box allows you to show or hide the aperture for the cursor. If Show Aperture is not selected then the cursor is displayed as cross-hairs without the circle. For more information on the aperture, see the following section.



---

**Tip** Hold down the ALT key to temporarily disable running snaps for any one instance when you left click the mouse to place a point.

---

### Using the Aperture

The aperture is a circle that is centered on the cross-hairs, shown to the right. The aperture provides a visual clue that your cursor is close enough to an entity to snap to it or select it. If the object is outside the circle it won't be selected and most snap commands will be ignored.

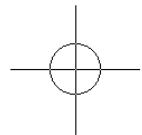

The size of the aperture circle is set by the Search Tolerance edit box on the Settings *System1* dialog.

### Displaying the aperture

1. Select Snaps>Running Snaps, *or*
2. In the Running Snaps dialog, check the Show Aperture check box.

You can also type **AP** from the keyboard to toggle Aperture on and off, or set it from a checkbox on the Utilities>Settings>General dialog.

---

**Note:** When you select the Show Aperture check box in the Running Snaps dialog, the aperture is visible even when Running Snaps are turned off.

---

### To change the size of the aperture:

1. Select Utilities>Settings.
2. In Settings, click the *System1* dialog.
3. In the Search Tolerance box, type a value to specify the distance you want snaps to be active. The size of the aperture will change to reflect the value in the Search Tolerance box.

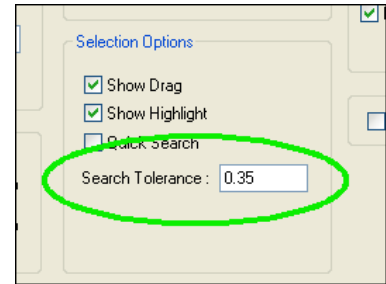

## Using Tracking to Place Temporary Points

---

Frequently while drawing, you might start constructing an object but don't know the precise location of the second or third point you need to place. Or you might start a line command, but before placing the first point, you decide you want the line to begin an exact distance from the endpoint of an existing object. Rather than cancel the operation, you can nest a command that enables you to interrupt the action temporarily until you locate the point, and then start or continue the drawing operation.

Tracking enables you to set the location of points before you place them. You can start the Track command at any time after starting a drawing tool, whether or not you have placed any points.

As soon as you select Snaps>Track, you draw a rubberband line that will vanish when you use the Track End or Pen Up (**PU**) commands, leaving the cursor in a location ready to place the next point in your drawing. When tracking, you can use any coordinate system, drawing constraints such as ortho mode, and snaps to aid you in finding a location in your drawing.

### Using Tracking to Locate a Point

Tracking is useful for finding the precise location where you want to break a wall to insert a window or door. It is also useful when inserting a symbol into a drawing, because you can track to an exact location, and a Pen Up will both end the tracking command *and* place the symbol.

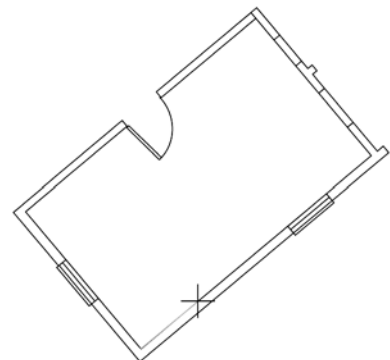

**To locate a point in your drawing using tracking:**

1. After starting a drawing command, select Snaps>Track, or *Track* on the right click popup menu, or type **TK**.
2. Begin “drawing” from a known coordinate in your drawing, using snaps, constraints, direct distance entry and any other drawing tools as aids to locate the first point.
3. Continue creating other points if desired.
4. When you locate the last point, right click and select *Track End* (or type **PU**).
5. The drawing command will continue from that point, prompting you with further instructions depending on which tool you are using and where you were at in the command when you started Tracking.

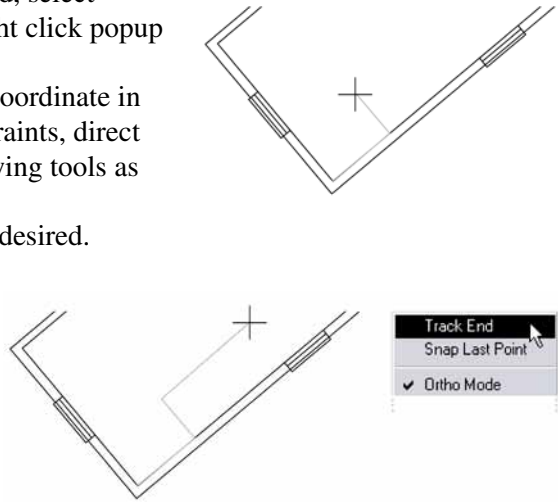

---

**Tip** See the Tracking topic in the Help file for a step by step example of using the Track command to find the center of a rectangle created with 4 single lines.

---

## VIEWING THE DRAWING

Because Visual CADD has an unlimited drawing area and you draw objects at actual size, you will often need to view an area of the drawing that is not on the screen.

You have several options for changing the view of your drawing:

- Zooming in and out to see more or less detail.
- Panning left and right or up and down to change the view.
- Bird's-eye view, to open a thumbnail view of your entire drawing.

Visual CADD offers a wide range of zoom and pan tools on the Zooms menu for navigating to a specific view of the drawing, including the new v6 AutoPan.

### Zooming and Panning

---

#### Using a Wheel Mouse

The most effective way to navigate around a drawing is by zooming and panning with a mouse wheel. Roll the wheel forward or away from you to zoom out and roll back towards you to zoom in. Hold down the SHIFT key and roll to pan the drawing right and left, and CONTROL key to pan the drawing up and down. New in Visual CADD 6: hold down the middle button and drag the mouse to pan the drawing.

You can change several settings on the Utilities>Settings>System2 dialog to modify how the mouse wheel works. These include reversing the wheel direction so that rolling forward zooms in, and setting values for the amount of zoom and pan with each click of the scroll wheel. See the Help file for more details on mouse settings.

#### Scrollbars

By default scrollbars are toggled on when you first open Visual CADD. Using a wheel mouse makes the scrollbars somewhat redundant --many people turn them off to increase the viewable drawing area. To toggle scrollbars off, right click on either one and untick the *Scroll Bars* option on the popup menu. To toggle them back on, right click on the status bar or one of the toolbars. Run the *Save Current Environment* command (EN) to make the change “stick” the next time you open Visual CADD.

## **Zoom Pan (PA)**

Centers the view around a point you choose by clicking in the drawing after you select Zooms>Pan from the menu. The magnification or zoom level of the drawing doesn't change. Pan is useful for viewing portions of the drawing that lie beyond your current view.

## **Zoom AutoPan (AA)**

Allows you to drag the drawing around onscreen by holding down the left mouse button after you start Zooms>AutoPan (or type **AA** from the keyboard). Release the mouse button to end the command and the screen will redraw with the current view you have selected. Press the scrollbar if you want to immediately repeat the command.

If your mouse has a middle mousewheel, you can just press and hold down the middle mousewheel without having to type **AA**. Drag the drawing to pan it and release the mousewheel when you are satisfied with the view and the screen will redraw.

## **Zoom All (ZA)**

Fills the screen with the entire drawing. It is useful when you want an overview of your work.

## **Zoom Window (ZW)**

Fills the screen with the objects contained in a selection frame you draw. Click to select the first corner point, drag the cursor and select the opposite corner point. The screen display will zoom to the window created by those two points.

## **Zoom In (ZI)**

Enlarges the view using the multiplier you set for Zoom Factor (set on the *System1* screen of the Settings dialog). You can also set Visual CADD to prompt you to click in your current view to locate the center of the new zoom view. If you do not set the prompt, the new view will use the same center of view as the current view.

## **Zoom Out (ZO)**

Reduces the view by the Zoom Factor (set on the *System1* screen of the Settings dialog). You can also set Visual CADD to prompt you to click in your current view to locate the center of the new zoom view. If you do not set the prompt, the new zoom view will use the same center of view as the current view.

## **Zoom Selected (ZS)**

Fills the screen with the objects that you have selected on-screen before starting the Zoom>Zoom Selected command. Zoom Selected is useful for focusing on specific objects. The objects remain selected after the zoom command finishes, so you can start another command, for example if you want to move or copy the objects.

## Zoom Previous (ZP)

Returns to the previous view. Zoom Previous is useful when you are editing at a close in view and want to return to an overview or adjacent view. Repeating the command will toggle between the two most recent views set by the other zoom and pan commands.

## Zoom Value (ZU)

Enlarges or reduces the view by a ratio of the actual size of the objects. You set the ratio on the ZoomValue speedbar, select [OK] (or ENTER) and then click to locate the new center of the window. A value of 2, for example, displays objects at twice their previous size. See the Help file topic for a more complete explanation.

# Birds-Eye View

---

From the View menu click on Bird's-Eye View (or type **ZB**) to open a small window displaying a thumbnail of your drawing. Click in the bird's-eye view window to center the new drawing view around that point. Right click for other options. You can "roll up" the dialog by double clicking on it so that only the title bar is displayed. Roll it back down again when you need to use Bird's-Eye View by double clicking on the title bar.

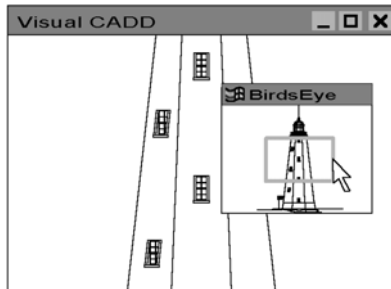
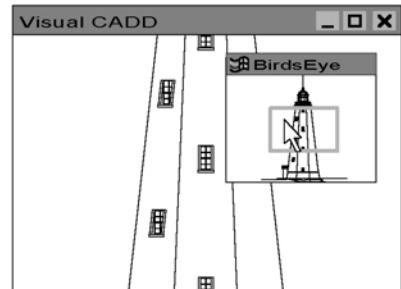

Click the left mouse button and hold it down to grab the selection frame in the bird's-eye window and drag it to a new location. To create a new frame, hold down SHIFT as you drag to draw a selection frame within the existing selection frame and release to set the lower right corner.

---

**Tip** Hold down the left mouse button and drag on any border to resize Bird's-Eye View.

---

# Naming Views for Easy Reference

---

If you find yourself returning to the same view repeatedly in a drawing, you can name the view and then quickly select it later from a list of saved views.

### To name the current view for later use:

1. Select Zooms>Name View or type **NV**.
2. In the speedbar, enter a name.
3. Click [OK] or press ENTER.

### To use a named view:

1. Select Zooms>Zoom View or type **ZN**.
2. Select a named view from the list, and then click [OK] or press ENTER.

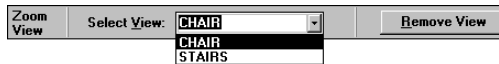

### To delete a named view:

1. Select the Zooms>Zoom View or type **ZN**.
2. Select a named view from the list, and then select the Remove View button.
3. Click [OK] or press ENTER to end the command.

## Working on a Drawing in Multiple Windows

---

In Visual CADD, you can open multiple windows to work simultaneously with several views of the current drawing. You can open up to 64 windows, depending on the amount of memory in your computer.

Having multiple views open is a good technique for working on different parts of a large drawing, such as a floor plan of a house or office building. You can start a tool in one view and end it in another. For example, begin a line in one view and move the cursor to the other view. The rubberbanding as you drag the mouse will show in the second window and you can place a point to complete the line.

When you save a drawing, you also save the number and arrangement of windows as well as the view each window displays, including layer information. When you open the drawing file again it opens to the same set of windows.

### Using Multiple Windows

Display different layer information in multiple windows.

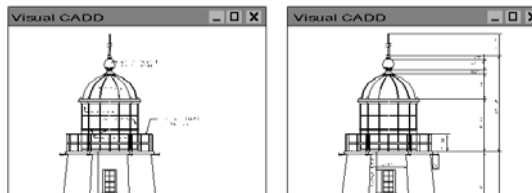

Use the Zoom In command to see enough detail to snap points precisely to each of the two opposite ends of a drawing.

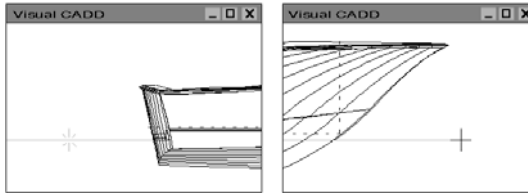

---

**Tip** Use Tile Horizontal or Tile Vertical from the Windows menu to arrange the views of your drawing. Drag the borders of a window with the mouse to resize the window.

---

**To open a new window displaying the active drawing:**

Select ZOOMS>Multiple Views>Create New View (VW).

**To do a Zoom All command on all open views:**

Select ZOOMS>Multiple Views>Zoom All Views.

**To refresh each open view of a the current drawing:**

Click the ZOOMS>Multiple Views>Redraw All Views, or hold SHIFT and perform a redraw by typing the 2 letter command **RD** or pressing the Redraw button on the toolbar. The views will be refreshed but the current zoom level of each view will not change.

---

**Tip** To delete a view, close it with the "x" button in the upper right corner of the window of the view, then save the drawing.

---



# MODIFYING OBJECTS

In conventional drafting, you hope to draw objects only once. But in fact, the old adage advises: draw no more in the morning than you can erase in the afternoon. It's quite different when drawing in CADD.

You tap the power of Visual CADD when you need to alter and manipulate objects. After drawing basic shapes, use the editing tools to quickly refine them.

As part of a building renovation, for example, you need to complete as-built drawings and reconcile some of the measurements. In Visual CADD, it is easy to stretch individual lines to change the drawing.

As part of a new building design, you will want to add windows or doors to the walls after first drawing them. In Visual CADD, you simply break the lines and then place the symbols for doors and windows where the lines break.

Perhaps you're ready to draw building elevations. In Visual CADD, you can extend construction lines from the plan into an adjoining area of the drawing and start to draw the elevations. Once completed, you can trim the construction lines back to the plan.

When drawing a complex mechanical part such as a cam, for example, you can draw the ellipses and arcs that make up the cam shape, and then use Booleans to create a smooth final shape.

In the hundreds of modifications you make in a drawing, the ability to quickly make editing changes greatly increases your productivity.

## Selecting and Deselecting Objects

---

Visual CADD provides tools to select only the objects you want to edit. You can select objects individually, in groups, and by type, properties or layer by using the Selection tool, the Group command, the Select commands on the Edit menu, or the buttons on the selection speedbar. Objects remain selected until you either edit them or explicitly deselect them. Select a set of objects to edit by repeating and combining selection commands to build a selection set. If you have not selected any objects before beginning to edit, Visual CADD prompts you to select an object and opens the selection speedbar. You can open the selection speed bar at any time by typing **S1**.

## Using the Selection Tool



The default selection tool selects an object when you click on that object. To select multiple objects, hold down the **SHIFT** button as you click additional objects, or when you draw a selection frame around a group of objects.

The selection tool deselects all objects when you click in an empty portion of your drawing, and a single object when you press **CTRL** and then click the selected object.

**Tip** To select most but not all the objects in your drawing, select **Edit>Select By>Select All** (or type **SA**), and then deselect unwanted objects.

## Selection Settings

### Search Tolerance

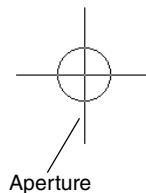
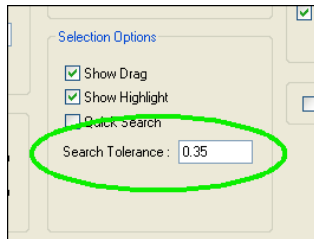

Search Tolerance, found on the *System1* screen of **Utilities>Settings**, specifies the maximum distance the cursor can be from an object for Visual CADD to snap to or select it. The Search Tolerance value also determines the size of the aperture. Anything within the aperture is

within the snap or select range specified by the Search Tolerance. Although it is a handy reference, the aperture does not need to be visible onscreen. Toggle it on/off from the Snaps menu, the Running snaps dialog (**RN**) or by typing **AP**.

### Quick Search

If *Quick Search* is checked, the object drawn earliest within the search tolerance of the cursor is selected when you left click.

### Backward Redraw

With *Backward Redraw* checked on the **Zooms** menu and *Quick Search* checked on the *System1* dialog, the object drawn most recently within the search tolerance of the cursor is selected when you left click.

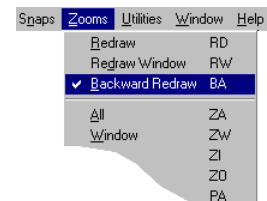

### Selection Color

By default, objects appear pink (Magenta) when selected with the cursor. You can change the color of selected objects from the *Selection* dropdown list in the *Display Colors* section of the *System1* dialog from the **Settings** menu.

## Selection Tools

---

The following selection tools are available from the Selection speedbar (**S1**), or from the Edit>Select By menu section.

### All (SA)

When you choose this tool, all objects in the drawing are selected.

### Window (SW)

The tool draws a box enclosing the objects that you want to select. Click and hold the left button and drag the mouse to the right and release the mouse to define the opposite corner. Objects whose endpoints are completely within the window will be selected.

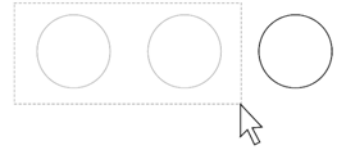

### Crossing (SX)

When you choose Crossing, you are prompted to draw a box from right to left that encloses or touches all of the objects you want to select. The tool differs from Window in that any object touched, regardless of whether the endpoints are within the crossing window, will be part of the selection set.

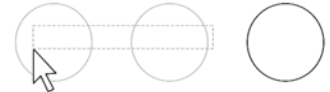

---

**Tip** If you are drawing with the Selection arrow as your default tool, simply click and hold to set first point and then drag the box to the right to enclose a window selection, or to the left to create a crossing selection. If you are drawing with single or continuous line as the default, type **SE** and these options will be available. 3 commands in one!

---

### Object (SB)

Selects a single object. When you start this tool you are prompted to select an object by clicking on it.

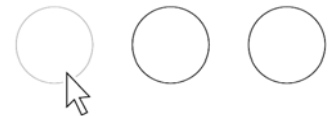

### Last (SL)

Selects the objects that were first selected during the last editing operation or before the last selection was cleared using the Clear List tool. If you selected 4 objects and copied them, this command will select the 4 original objects and not the copies.

### Modified (SU)

This command selects the last copied object or objects in the drawing. It is an alternate to Select Last, which only selects the original objects you first selected to use in creating the new copied objects.

## Last Object (LO)

Selects the last object placed in your drawing. This can be a new entity, such as a line just drawn, or a modified entity, such as a line or circle that is copied from an existing entity.

Note that this command is different from Select Last, which only selects the last unmodified entities in the drawing, and Select Modified, which selects the last copied entities.

Select Last Object doesn't care. It selects the last object placed in the drawing. To select multiple objects, press the spacebar to repeat the command.

## Adjoining (SJ)

When you click this tool you are prompted to select an object. When you click one of the objects in a series of objects that share end points all objects in that series are selected. Press TAB to display branching selection alternatives, and then click to select.



## Layer (SY)

This tool selects all objects on the layer you specify.

## Invert List (IS)

This tool deselects all selected items and selects all other items in the drawing.

## Clear List (CS)

This tool deselects all selected items.

# Selecting Objects by Properties and Type

---

Using the Selection Filter command, you can specify criteria for quickly selecting multiple objects to modify them. Select objects based on type of entity, color, linetype, linewidth, and/or layer. You can select text that uses a specific font. And you can select a symbol, hatch or Reference Frame by name to find all occurrences of that symbol or hatch or RF.

## Selection Filter Speed Bar

The Selection Filter speedbar opens when you select Edit>Selection Filter.

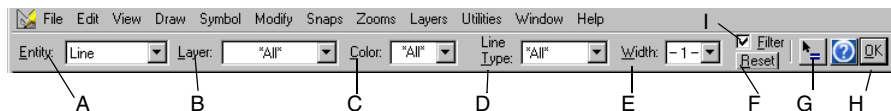

|   |  |
|---|--|
| A | Sets the type of object as a search criterion.   |
| B | Sets a layer as a search criterion.  |
| C | Sets the color of objects as a search criterion.   |
| D | Sets the line type of objects as a search criterion.   |
| E | Sets the line width of objects as a search criterion.  |
| F | Resets the selection filter speedbar criteria to All.  |
| G | When clicked, sets the selection filter criteria to match the properties of the next object you click. |
| H | Saves the new criteria and closes the selection filter speedbar.                                       |
| I | When checked, turns on the Selection Filter.   |

When you tick the Filter checkbox on the Selection Filter speedbar, or the Use Filter checkbox on the Selection speedbar (**S1**), and then apply a selection command, it selects only those objects that meet all of the filter criteria you have set on the selection filter speed bar. For example, you can select all red entities on layer 5, or all Bézier curves with line type 8.

Use the Selection Filter speedbar to quickly select specific objects in a complex drawing. See the Help file for additional details and a number of tips on how to get the most out of this tool.

**Tip** To select objects based on more than one set of criteria, set the selection filter for the first selection criteria, perform the selection, and then set the filter for another set of criteria and select again.

### To select objects by properties and type:

1. From the menu choose Edit>Selection Filter or type **SF** to start the command. Filter criteria from the last time the filter was used will appear. Click the Reset button to clear old data.
2. Select an Entity type and then other criteria from the drop-down lists, make sure the Filter checkbox is ticked, and then click [OK].

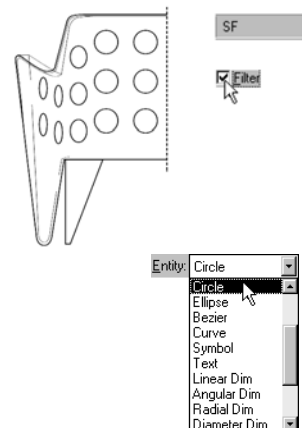

3. Use an appropriate selection command or tool, such as *Select All*, to select objects using the criteria of the selection filter.
4. Make changes to the selected objects as desired. For example, change the font of all selected text or the color or linewidth of all selected lines.

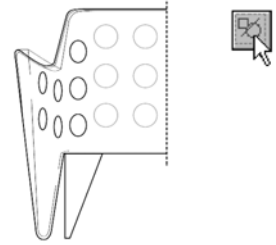

---

**Tip** To use an object in the drawing as a selection criterion, click Match  on the selection filter speedbar, and then click the object. Visual CADD will apply all properties of the object into the selection filter boxes.

---

## Creating Groups

---

The Group commands are powerful tools that will help organize your drawings. A Group is created when you select a collection of objects and run the Group command. Now, any time you select any object in the group, the entire group is selected in the drawing. A Group is saved with a drawing.

Groups are similar to Symbols in that several objects become one object, but they are also quite different. A Symbol has a name and can be saved to disk and then inserted into any other drawing via the Symbol Manager. A Group exists only in the drawing it was created in and cannot be saved to disk separately from its drawing. However, you can *Copy* and *Paste* a Group into another open drawing. And if you *Merge* a drawing into another drawing, any Groups that exist in the original drawing will also be merged into the other drawing.

One advantage Groups have over Symbols is that they can be easily modified. Once a Symbol is created, to make any changes you must explode it into individual objects, make the changes, and recreate the Symbol. With a Group you can modify all objects at once, or by pressing the ALT key, select an individual object in the Group and modify it without affecting other objects in the Group. Save the drawing to save the change in the Group.

Groups can be selected with all the usual selection tools. You can Ungroup any Group to return it to a collection of individual objects, and add or remove objects from an existing group. See the Help file for complete details.

## Deleting Entities and Undoing Actions

---

In Visual CADD, you can delete a selected object or group of objects, the last point placed, the last object drawn, or the entire drawing.

You can also undo drawing or editing actions. If you accidentally undo an action, you can redo it. Visual CADD doesn't limit the drawing actions you can undo and redo.

If you run the Pack Data command from the Utilities menu, you can only undo and redo the drawing actions that follow that command. The Pack Data command deletes all record of earlier changes from the drawing database, to free up memory.

We recommend that you use the Pack Data command occasionally on each drawing to clean up the drawing database. In order for undo/redo to function properly, each entity must remain in the database, even after it has been erased from the screen. File sizes can become quite large, and occasionally corrupted drawings result. Use Pack Data in each drawing when you are satisfied that you no longer need to undo/redo recent work.

### To Delete an Object or Objects:

1. Select the object or objects you want to delete.
2. Press the DEL key or type **ER**.

| To...  | Do this...  |
|--|---|
| Delete one or more selected objects  | Select the object(s) you want to delete, then select Edit>Erase, type <b>ER</b> , or press DEL.   |
| Delete the last object drawn or modified   | Select Edit>Erase Last or type <b>EL</b> .  |
| Remove the last segment drawn while drawing a continuous line, irregular polygon, a boundary hatch, or a boundary fill | Right-click and then select Undo Vertex or type <b>UV</b> .                                       |
| Undo your last operation   | Select Edit>Undo or type <b>OO</b> .  |
| Cancel the last Undo   | Select Edit>Redo or type <b>RE</b> .  |
| Delete the entire drawing  | Select Edit>Clear Drawing. Caution: Once you clear a drawing, you cannot retrieve any part of it. |

## Viewing the Results of Your Edits

When you move, delete, or change an object that overlaps another object, the screen displays a break in the remaining object. Selecting Zooms>Redraw or typing **RD** updates the screen display.

Redraw time for a complex drawing can be lengthy if you have an older machine, so you might want to redraw only the portion of the drawing on the screen.

By default, Visual CADD redraws objects in the order in which they were drawn. You can reset Visual CADD to redraw the newest objects first, which is useful when you want to update only the last few entities drawn.

### To redraw only a portion of a drawing:

1. Select Zooms>Redraw Window.
2. Draw a selection frame around the area you want to update.

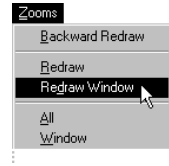

### To redraw newest objects first:

Select Zooms>Backward Redraw to check it.

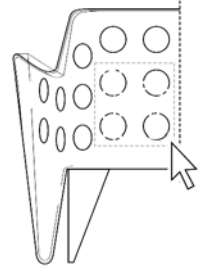

## Breaking Lines

---

Visual CADD has two break commands: Break and MultiBreak. Use them to create a gap in any object(s) except text, dimensions, symbols, attributes, hatches, and fills. For example, use MultiBreak to break the lines delineating a wall to insert a door symbol.

When you apply a break:

- Polygons and rectangles remain continuous lines.
- Circles become arcs.
- Ellipses become elliptical arcs.
- Open objects, such as continuous lines and arcs become two objects of the same type.

Break is a persistent command, enabling you to break any number of objects, one after another. Break repeats until you press ESC or choose another command or tool.

MultiBreak, on the other hand, is not persistent. To repeat this command, press the spacebar.

### How Far Can a Gap Span?

In lines drawn with the Continuous Line tool, the Continuous Bézier tool, and the Spline Curve tool, you can begin a break at any point in one segment and end it at any point in another segment.





### To insert a gap in a line:

1. Select Modify>Break from the menu or click on the toolbar button.
2. Click the object in which you want to create the break.
3. Place a point where you want the break to begin.
4. Place a point where you want the break to end. When finished, press ESC.

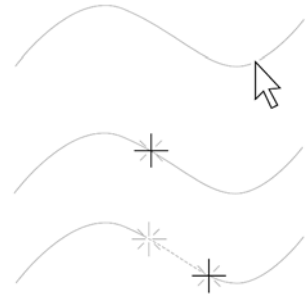

The same sequence applies to the MultiBreak command, except that you should select objects *before* starting the command, and since it is not a persistent command it does not require an ESC; it will end when you place the second break point.

---

**Tip** Any command in Visual CADD can be repeated by pressing the spacebar.

---

## Extending Lines to Objects

---

You can extend portions of already drawn lines to another object. You can extend any line, arc, or complex curve to any entity except text and attributes. Separate tools give you the option to extend one line or several lines at once.

*Extend Single* is a persistent command, enabling you to extend a series of lines, one at a time. It repeats until you press ESC or choose another command or tool. *Extend Multiple* is not, and ends after completing one instance of extending multiple lines.

### To extend one line to an object:

1. Start the Extend Single tool from the toolbar, and then click the line you want to extend.
2. Select the object to which you want to extend the line. Repeat on additional lines as desired then press ESC to exit the command.



### To extend several lines to an object:

1. Select the lines you want to extend, and then start the Extend Multiple tool.
2. Select the object to which you want to extend the lines.

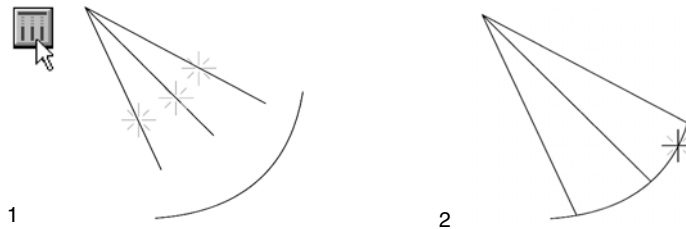

## Trimming Lines

You can quickly erase a portion of a line that extends beyond another simple line or complex object. Visual CADD has three Trim commands:

**Trim Single** deletes the portion of a line, arc, or complex curve that extends beyond another object. Trim Single is a persistent command, enabling you to trim a series of lines, one after another. Trim Single repeats until you press ESC or choose another command or tool.

**Trim Multiple** deletes the portions of more than one line, arc, or complex curve that extend beyond any other object except a complex curve.

**Trim Intersection** deletes the portions of crossing double lines that lie within their intersection.

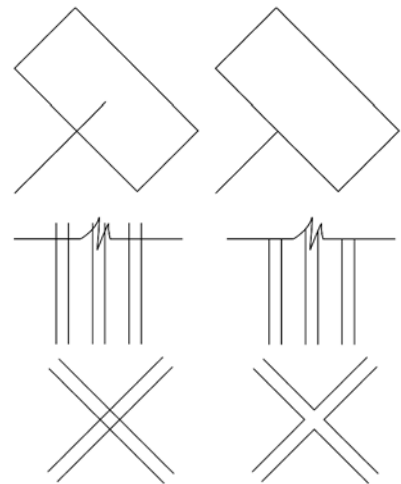

### To trim a single line:

1. Click the Trim Single tool from the toolbar, and then click the line you want to trim, on the end you want to retain.
2. Click the object that you want to trim the line to.
3. Continue steps 1 and 2 as desired to trim additional objects.
4. Press ESC or Pen Up to finish the command.

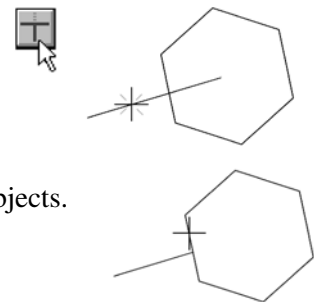

### To trim several lines at once:

1. Select the lines you want to trim, and then click the Trim Multiple tool from the toolbar.
2. Select the object to which you want to trim the selected lines.
3. Move your cursor from one side to the other of the object for a preview of trim options, and then click when you see the option you want.

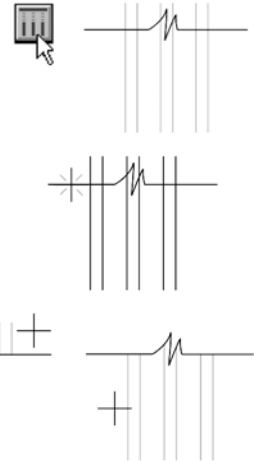

### To trim double lines at their intersection:

1. Click the Trim-Intersection tool from the toolbar.
2. Click inside the crossing of the two pairs of lines.
3. Move your cursor around the intersection for a preview of trim options, and then click when you see the option that you want.

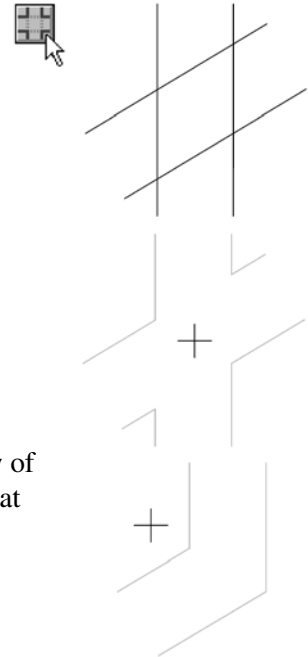

## Reshaping and Moving Objects

---

In Visual CADD, you can reshape any object except a symbol. When you reshape an object, you move some of its construction points without moving others. When you stretch an object, all selected construction points move. You can also move an object without changing its shape.

You can change the shape of an object by selecting one construction point and moving it with the Move Point command. Using Move Point in combination with the Near Point snap, you can also change the shape of multiple objects at one time if they each contain a construction point at a common location. Note that the Move Point command simply moves a symbol. You must explode a symbol before you can move points within it.

You can move an entire object precisely with the Move command. Move an object quickly but imprecisely by simply selecting it and then click and hold the mouse down as you drag it around the drawing.



### To reshape an object or objects by stretching:

1. Select an object or objects, select Modify>Stretch or click on the toolbar button.
2. Draw a selection frame around the points you want to stretch.
3. Place a reference point establishing the stretch's starting point.
4. Move your cursor to preview stretch results.
5. Place a reference point to establish the end point of the stretch.

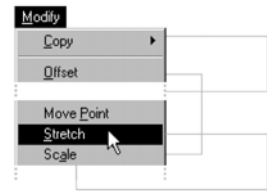

### To reshape an object by moving a point:

1. Select Modify>Move Point, and then select an object.
2. Place a reference point establishing the move's starting point.
3. Place a reference point establishing the move's end point.

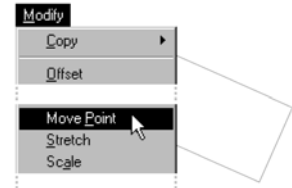

### To reshape multiple objects by moving a common point:

1. Select Modify>Move Point.
2. Move the cursor near the common point, and then type **NP**.
3. Place a reference point establishing the move's end point.



### To move an object or objects to a precise location:

1. Select an object or objects, and then select Modify>Move or click the button on the toolbar.

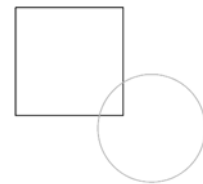

2. Place a reference point defining the move's starting point. Use a snap tool for precision placement.

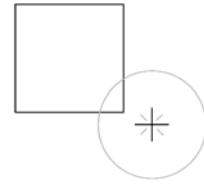

3. Place a reference point defining the move's end point. Here again, a snap tool will precisely place the move end point.

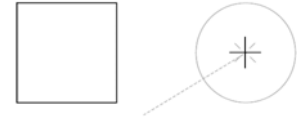

## Resizing Objects

---

When you draw an object and later want to resize it, or when you merge one drawing into another and want them at the same scale, you can use two scale commands.

The *Scale* command resizes an object at a ratio you specify. The *Fit Scale* command resizes one object to match the size of a second.

When you resize an object by using the Scale command, you can resize in both X and Y directions independently, thereby distorting the object. To avoid distortion and resize an object or group of objects proportionally, enter equal values for both X and Y axes.

Scale values of 1.0 are equivalent to full-size, or 100%. Values less than 1.0 reduce the selected object's size. Values greater than 1.0 increase the selected object's size.

In most cases, changing the X scale value for an object resizes the object in the horizontal direction, and changing the Y scale value resizes it in the vertical direction. The X and Y scale values of rotated text and symbols, however, rotate with them. For example, text rotated to a 90° angle resizes in the vertical direction when you change the X scale value.

### Changing Scale Values

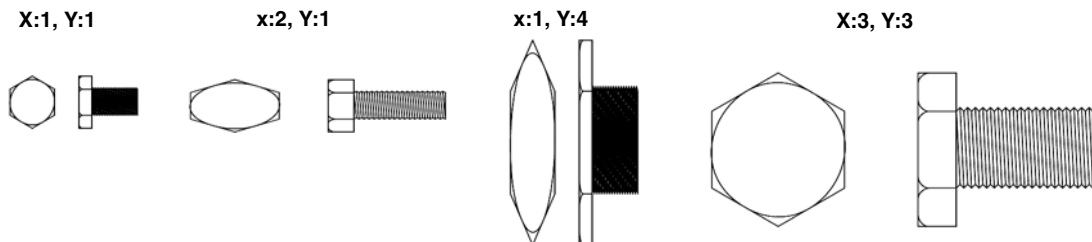

---

**Tip** Mirror an object around its X axis by entering a negative X value. Mirror an object around its Y axis by entering a negative Y value.

---



**To resize an object by changing X and Y scale values:**

1. Select the object or objects, select Modify>Scale or click the button on the toolbar.
2. Place a reference point establishing the point from which the object(s) will be resized.
3. Enter scale values for X and Y factors on the scale speedbar, and then click [OK].

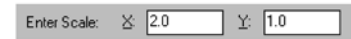

**To resize an object by example:**

1. Select the object or objects, select Modify>Fit Scale.
2. Place two reference points within the selection to serve as the base distance to resize.
3. Place two reference points anywhere in your drawing to establish the distance to which you want to resize the selected object or objects.

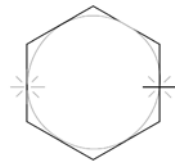

---

## Skewing an Object

---

Use the Skew command to change the shape of selected objects in the drawing. You will find the command useful on a wide range of objects, from rectangles and polygons to circles and arcs. The example shown is a rectangle that has had the Skew command applied.

**To skew a selection:**

1. Select the object(s) you want to skew.
2. Start the Skew command from the Modify menu or type **KW**.
3. Place an origin point. A speedbar will appear, prompting you for a Skew Angle.
4. Type in an Angle.
5. Click the [OK] button on the speedbar or press enter.

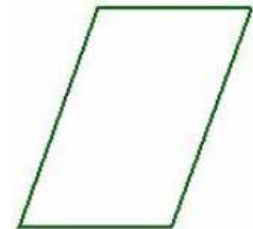

- As an alternate, with Ortho off, use the mouse to drag the object to set the angle. A dotted rubberband will show you a preview. Left click the mouse to set the skew angle.

## Rotating Objects

---

You can rotate an object or group of objects around any point that you place in your drawing. You can rotate precisely by entering an angle value; or you can rotate by moving the mouse (with *Ortho* off). The dotted rubberband will give a preview.

### Rotation Angle

Rotation angle  $0^\circ$  measures counter-clockwise from a 3:00 position.

If the object you want to rotate already lies at an angle, add the object's base angle to the angle of rotation for the new base angle.

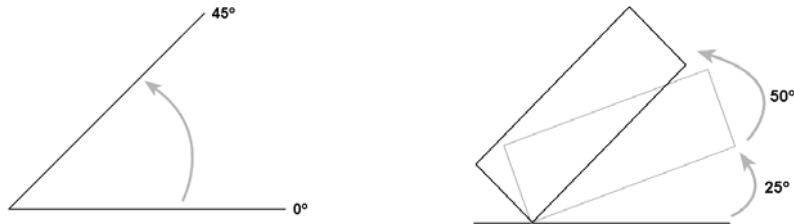

#### To rotate an object:

- Select an object or objects, and then select **Modify>Rotate** or click the Rotate button on the toolbar or type **RO**.
- Place a reference point for the center of rotation.
- Enter a Rotation Angle value in the rotate speedbar, and then click [OK], or move the mouse and then click to set the rotation.

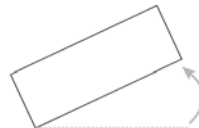
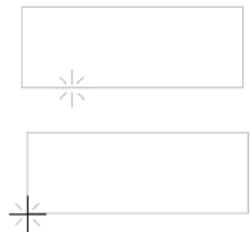

---

**Tip** Set the rotation angle quickly after Step 2 by clicking the match button on the speedbar and then select an object in the drawing whose angle you want to match. Press the [OK] button to finish.

---

## Moving and Rotating Objects in One Operation

---

To move an object(s) and change its angle at the same time, use the *Align* command. The *Align* command changes the orientation of an object or a group of objects to match that of an existing object *or* an angle that you create by placing points.

Moving and rotating is a three-step process. First, you define reference points on the selected object, then you define a target point to which the first reference point on the selected object(s) moves, and finally you define a target point that establishes the new angle of the moved object(s).

### To move and rotate an object:

1. Select one or more objects, then select *Modify>Align*.
2. Place two reference points on the selected object to define the move and rotation points.
3. Place a target point to establish where you want to move the first reference point on the selected object to. This can be a snap to an endpoint of an existing line, for example, or a click on a blank space in the drawing.
4. Place a second target point that defines the new angle of the selected object. Snap to the other end of an existing line, or click a second point in the drawing.
5. The first reference point of the object(s) will move to the first target point, and the object(s) will rotate to the angle specified by the second target point.

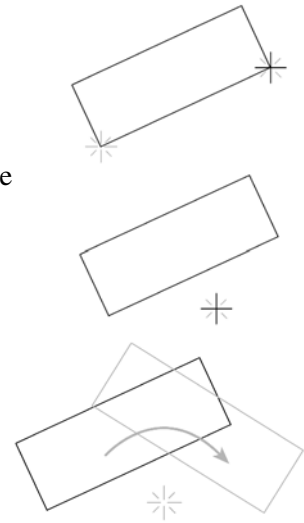

---

**Tip** To better understand *Align*, draw a rectangle at  $0^\circ$  and a line at  $45^\circ$  that is longer in length than the rectangle. Using the steps above, select the two reference points on the rectangle. Snap to the lower end of the line (first target) and then the upper (second target). The rectangle will move to the lower end of the line and match the angle of the line.

---

## Inserting a Chamfer or Fillet Between Two Lines

---

After you have drawn two lines that intersect, you can angle or curve the intersection. When you chamfer the intersection of two lines, a third angled line joins them. When you fillet the intersection of two lines, an arc joins them.

You can also set the double line tool to automatically fillet the corners of line segments as you draw. Do this by setting the *Auto Fillet* option from the menu *Utilities>Settings General* dialog or on the *Double Line Settings* speedbar.

**Note** Both the Chamfer and Fillet commands are persistent, repeating until you press ESC, select another tool, or choose another command



**To insert an angled intersection between two lines:**

1. Select the chamfer tool.
2. Right click, and then select *Chamfer Dist*.
3. On the Chamfer speed bar, set the Chamfer distance(s) using the TAB key, and then click [OK] or ENTER.
4. If only two entities intersect, click between them. If more than two entities intersect, click the two that you want to chamfer.

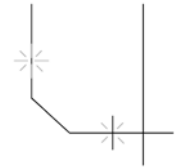
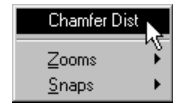

**To insert a fillet between two lines:**

1. Select the Fillet tool.
2. Right click, and then click *Fillet Radius*.
3. On the Fillet speed bar, set the Fillet Radius, and then click [OK].
4. If only two entities intersect, click between them. If more than two entities intersect, click the two that you want to fillet.
5. Move the cursor around the intersection for a preview of the fillet options, and then click when the preview fillet is located correctly.

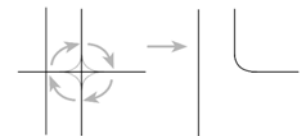
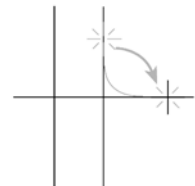
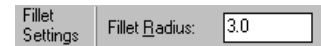

**To curve the vertices of a double line as you draw:**

1. Start the Double Line tool.
2. Right click, and then click *Fillet Radius*. Enter a value in the Fillet Radius box on the Fillet speedbar, and then tick the Auto Fillet checkbox.
3. Tick the Preview Fillet checkbox to see the fillets as you draw, and then click [OK] to close the speedbar and begin drawing.

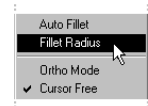

# Exploding and Joining Objects

---

When you want to edit an object contained in a compound or *complex* object, such as a symbol or dimension, you must first explode the object. You can join individual lines to create a single object.

## Exploding Objects into Their Basic Components

---

The various complex objects will explode in different ways:

- Continuous lines, rectangles, and polygons into collections of single lines
- Continuous Bézier and spline curves into collections of single Bézier curves
- Dimensions into lines, fills, and text blocks
- Vector text into lines and arcs
- Symbols and attributes into the objects and text blocks used to create them
- Hatch patterns into collections of individual lines
- Fills into the lines that bound them

You cannot explode basic objects, such as single lines, arcs, circles, ellipses, single Bézier curves, and TrueType text.

If the object you are exploding contains compound objects, you may need to explode it several times before you are able to select the entity you want to edit.

---

**Tips** Select exploded objects easily with the Select Adjoining tool found on the Edit menu.

Explode continuous lines, rectangles and polygons when you draw them by ticking the *Explode Cont. Lines* checkbox on the Utilities menu Settings>System1 dialog.

---



### To explode an object into its basic components:

1. Select the object that you want to explode.
2. Select Modify>Explode from the menu or click on the button in the toolbar.

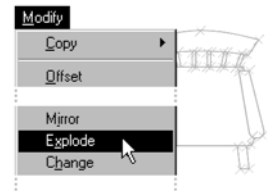

## Joining Objects

---

The Join command creates one object from a series of lines that are connected. For example, if you create a series of line segments using the Continuous Line tool, and then explode it to create separate segments, you can rejoin the lines using the Join command.

### To join a series of line segments:

1. Select the line segments you want to join.
2. Select Modify>Join.

## Creating Copies of an Object

---

Visual CADD provides you with several ways to copy a selected object or objects:

- Copying to and pasting from the Windows clipboard
- Using one of the Copy commands
- Creating a mirror-image copy

The Cut and Copy commands on the Edit menu place copies of selected objects on the Windows clipboard. When you choose Paste from the Edit menu, Visual CADD copies the object from the clipboard to your drawing. The Copy and Paste commands are the easiest way to copy part or all of one drawing into another open drawing (you can also Paste the clipboard contents into other Windows applications).

The Mirror, Multiple Copy, Linear Copy, Single Copy, Radial Copy, and Array Copy commands let you copy objects precisely in your drawings using the Snap commands.

A mirror-image copy is useful when you're drawing an object with axial symmetry; draw only half the object and use Mirror to create the other half.

Four copy commands—Multiple Copy, Linear Copy, Radial Copy, and Array Copy—can produce as many copies of an object or objects as your computer's memory allows. You provide spacing and angle parameters, and the objects are arranged as you specify. Single Copy makes one linear copy of the object or objects you select.

## Choosing a Technique for Creating Copies of an Object

---

### Multiple Copy

Multiple Copy places duplicates of selected objects wherever you click in your drawing. You continue placing copies of the original until you click *Pen Up* or press ESC.

### Linear Copy

Linear Copy arranges duplicates of selected objects in a line. You set the number of copies you want, define the distance and direction between the original object and the first copy, and then set the distance between each object.

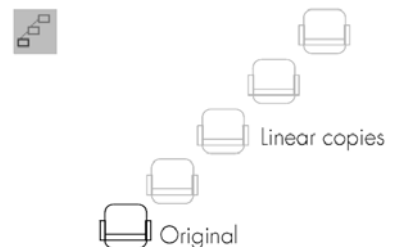

## Single Copy

Single Copy works the same as Linear Copy but duplicates the selection only once.

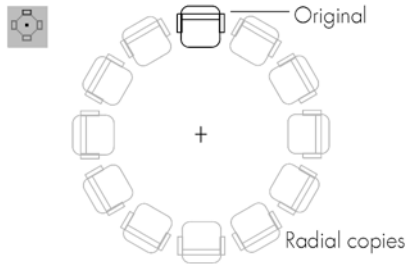

## Radial Copy

Radial Copy arranges duplicates of selected objects equidistant from a center point you place, rotating each to maintain the same relationship as the original object to the center point. You set the number of copies you want and the angle that the original and its duplicates will span.

## Array Copy

Array Copy arranges duplicates of selected objects in evenly spaced rows, forming a grid. You set the number of copies you want and the number of rows. You define the distance and direction between the original object and the first copy, and then define the distance and direction between rows.

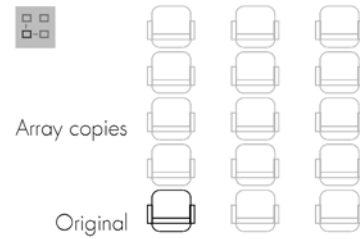

## Mirror

Mirror creates a mirror-image copy of selected objects around an axis you define.



### To create a mirror image copy:

1. Select one or more objects, and then click the Mirror tool from the toolbar.
2. Place a reference point defining the first point of the axis around which to mirror the object(s).
3. Place a reference point establishing the second point of the axis and setting the copy's position

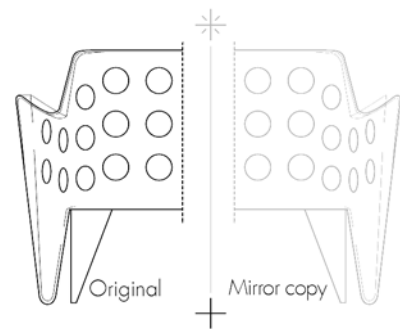

### To create multiple copies:

1. Select one or more objects, and then click the Multiple-Copy tool.
2. Place a reference point on the object(s) to create a handle.
3. Click in your drawing to place each copy. To finish, right click and then select Pen Up.



### To create a single copy:

1. Select one or more objects, and then click the Single Copy tool.
2. Place a reference point to define the starting point of the copy.
3. Place an offset point to define the location of the copy in the drawing.



### To create a linear copy:

1. Select one or more objects, and then click the Linear Copy tool from the toolbar.
2. On the Linear Copy speedbar, enter the number of copies (not including the original object), and then click [OK].



3. Place two reference points anywhere in your drawing to establish the distance between each.

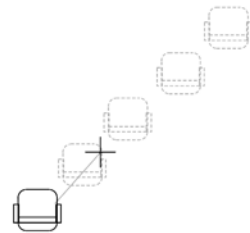

### To create radial copies:

1. Select one or more objects, and then click the Radial Copy tool from the toolbar.
2. On the Radial Copy speedbar, enter the number of copies (including the original object) and the span angle, and then click [OK].



3. Place a reference point anywhere in your drawing to define the center point of the circular array.

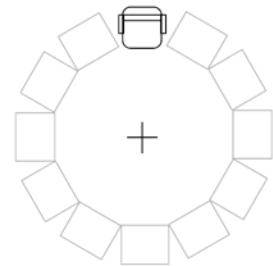

### To create an array copy:

1. Select one or more objects
2. Click the Array Copy tool from the toolbar.
3. On the Array Copy speedbar, change the number of copies to be in each row (not including the original object) and the number of rows, and then click [OK].

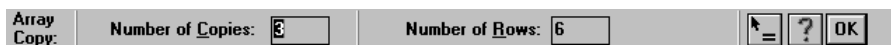

4. Place two reference points anywhere in your drawing to define the distance and direction between the original object and the adjacent copy.
5. Place a reference point to define the distance between rows.

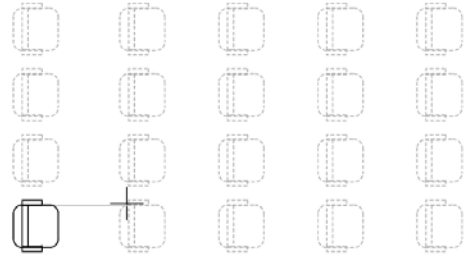

---

**Note** Copied objects always take on the properties of the object(s) you are copying from, no matter what settings are current in the drawing. Objects that are Offset (described below) always take on the current drawing properties.

---

## Offsetting Objects from an Original Object

---

Use the offset tool to create an object that is parallel to and around or inside the selected objects. The offset tool often makes a scaled copy of the original object, but it also frequently results in an object that is quite different from the original.

You can offset a single entity or an object composed of multiple entities. You also can set the distance of the offset copy from the original visually or numerically.

### Typical Offset Results

Use the offset tool to make scaled copies of many regular object.

Several entities change type when they are offset:

- Continuous bezier becomes a Single Bezier curve
- Ellipses becomes a Continuous Bezier curve
- Elliptical arc becomes a Continuous Bezier curve
- Spline curve becomes a Single Bezier curve



### To offset an object:

1. Select an object, and then click the Offset tool.
2. To preview more than two offset options, make sure *Fixed Distance* is unchecked. To specify a precise offset, enter a value in the Offset Distance box,



check *Fixed Distance*, and then click [OK].

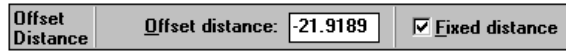

3. If *Fixed Distance* is unchecked, move the cursor inside and outside the original object to preview the offset options, then click when you see the option you want.



---

**Note** An object created by the Offset command takes on the current property settings, which may be different than the properties of the original object. This is different than the Copy command, in which the copy retains the properties of the original object regardless of the current settings.

---

## Dividing Objects into Equal Parts

---

With the Divide command you can divide lines, arcs and circles into any number of equal segments. You have the option of simply placing Points on the entity or actually breaking it into new objects of equal length.

There are many uses for this tool while drawing and editing. For instance, you could draw a line from floor to floor in a building section and then divide the line into equal spaces to locate where the stair treads and risers will be placed.

### To Divide objects:

1. Select an object or objects to divide.
2. Begin the command by selecting Modify>Divide from the menu or typing **IV**.
3. Input the number of segments that you want to divide the object into.
4. If needed, change the setting to either add points or actually break the object.
5. Click [OK] to complete the command.

## Combining Objects to Create a New Object

---

Sometimes creating an object by combining existing entities is easier than drawing it from scratch. The Boolean command joins two selected, overlapping closed objects of any type into a mixed entity path, enabling you to preview and choose from at least three variations. You preview these options by moving your cursor around the selected objects. The variations create an object that results from:

- The union of the selected objects, retaining all outer portions
- The intersection of the selected objects, retaining only those portions that intersect

- The subtraction of one object from the other, retaining portions that lie outside the limits of the other

## Boolean Variations

To create a new object from existing entities:

1. Select two overlapping closed objects, then select **Modify>Boolean**.
2. Move your cursor around the objects for a preview of Boolean options, and then click when you see the option that you want.

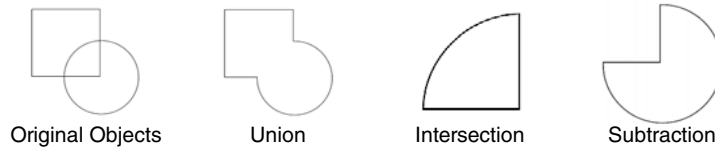

## Using Polygon Merge and Split

---

You can split or merge polygons using these commands.

### Polygon Merge

The Polygon Merge command joins together two polygons that are touching or overlapping.

#### To merge two polygons:

1. Select two polygons that are touching or overlapping.
2. Select **Modify>Merge Polygon**. The two polygons join to become one object.

### Polygon Split

The Polygon Split command, splits a single polygon into two or more polygons along one or more cut lines that you specify.

#### To split a polygon:

1. Select the polygon that you want to split.
2. Select **Modify>Split Polygon**. Notice that the Status Bar prompts you to enter a start point.
3. Click in the drawing area (or enter coordinates) to specify the start and end points of the line that will split the polygon.
4. If you want to split the polygon into more than two objects you can create more line segments to split the polygon.

5. When you have finished defining the cutting lines, double click or right click and select Pen Up. The polygon is split into two or more separate objects.

## Draw Order

---

The four Draw Order commands change the display and Print/Plot order of objects already placed in Visual CADD. In addition to moving objects to the "front" or "back" of the sort order, you can order objects relative to another object (that is, above or below a selected object).

As new objects are drawn, they are placed last in the draw order database, so they draw first, or in front of other objects. Draw Order maintains a separate list that keeps track of objects in relation to each other, allowing for precise placement when you modify an object with one of the four commands.

### **Bring to Front (DWF)**

Moves the selected object(s) to the top of the order of objects in the drawing, so that they draw last.

### **Send to Back (DWB)**

Moves the selected object(s) to the bottom of the order of objects in the drawing, so that they draw first.

### **Bring Above Object (DWA)**

Moves the selected object(s) above a specified reference object. After selecting an object and starting the command, the tool will prompt you in the status bar to specify the reference object that you want the selected object to draw above or on top of.

### **Send Behind Object (DWH)**

Moves the selected object(s) below a specified reference object. After selecting an object and starting the command, the tool will prompt you in the status bar to specify the reference object that you want the selected object to draw behind or under.

## Changing Properties

---

Use the Change command from the Modify menu to make changes to the 4 basic properties of selected objects: layer, color, linetype and width.

### To change the properties of selected objects:

1. Select one or more objects.
2. Start the Change command from the Modify menu or by typing **CG**.  
A speedbar appears with 4 dropdown boxes. If a single object or multiple objects with the same properties are selected, the current properties are displayed.  
If multiple objects with different properties are selected, three stars (\*\*\*) will be shown in the dropdown box. An example would be where one object has the color red and another the color blue.
3. Click on the dropdown box to expand the list of the property you want to change, and make a selection. Repeat for other properties if desired, then click [OK] or ENTER from the keyboard to complete the command.

---

**Tips** A quick way to change all properties of an existing entity to match those of another is to select an object(s), type **CG** then = sign, and click the entity that you want to match.

To change properties quickly from the keyboard, position the cursor on the Change speedbar, click the right mouse button, and click *Fast Properties*. The expandable dropdowns will disappear and are replaced by edit boxes. This allows you to type changes without having to move the mouse up to the speedbar. For example, typing *CL15* and then ENTER will immediately set the current layer to 15 without having to even look at the speedbar. In addition to **CL** for layer, other keyboard shortcuts to use with this method are **CP** for color, **TL** for linetype, and **WP** for linewidth.

You can also make changes to the properties from the dropdowns on the main toolbar. Select one or more objects, drop down a list and make changes. Repeat to change other properties. When finished, click in a blank area of the drawing or start a command to deselect selected entities.

---

## DIMENSIONING AND MEASURING

Dimensions enhance the clarity of graphical information in a drawing. They provide a sense of scale, and they define geometric relationships.

To create dimensions in hand drafting, usually the dimension is scaled to represent lines and other objects that are often much larger or smaller in the real world. In Visual CADD, you always draw at real-world scale, also known as 1:1, so you do not need to think of scale when creating dimensions. Simply define the points or objects to dimension, and Visual CADD creates an accurate dimension. You can override Visual CADD's measurement and provide your own dimension values if needed.

Dimension settings and properties allow you to match your Visual CADD drawings to your drafting standards. You can also adjust all or part of a dimension for legibility, after they are placed.

Visual CADD's dimensions update when you make changes to your drawing. You can stretch or scale objects, and their dimensions will update to reflect the changes, as long as the dimension is also part of the selection set. This is called associative dimensioning, and it makes it easy to revise drawings.

You can create Leaders, sometimes referred to as callouts, to describe an object or assembly. A leader is a text block with a line and arrow pointing to the objects.

Visual CADD has several tools for quickly finding distances, areas, and angles, so you can make measurements in a drawing without creating permanent dimensions.

Visual CADD 6 introduces the new Multiple Dimensions command, allowing you to quickly dimension several objects at once with a single command.

### Adding Dimensions to a Drawing

---

Adding dimensions to your drawing doesn't require knowledge of dimension settings; you can use the default Visual CADD settings to get started, and you can also change dimension settings before, during, or after creating a dimension.

Selecting points and objects precisely is crucial to accurate dimensioning. While creating dimensions, use the snap commands to select precise points on the drawing geometry rather than estimating endpoints or intersections.

### To create a single linear dimension:



1. Click the Linear Dimension tool.
2. If it is not already set, right click and select *Dim Mode : Single* from the popup menu.
3. Click anywhere on a line, or snap to the start and end points of the line for the dimension.
4. Drag the dimension away from the line with the mouse and click where you want to place it.

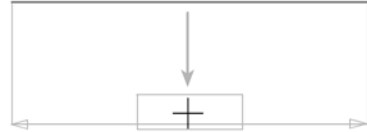

### To create a chain of linear dimensions:



1. Draw 3 horizontal lines that share common endpoints.
2. Click the Linear Dimension tool.
3. If it is not already set, right click and select *Dim Mode : Partitioned* from the popup menu.
4. Click on the first line or the start and end points for the first dimension of the chain, and then click where you want to place the dimension line.
5. Snap to the endpoints of the remaining lines and the dimensions will be automatically placed.
6. Right click and select *Pen Up* to end the command.



### To draw a baseline dimension:



1. Draw 3 horizontal lines that share common endpoints.
2. Click the Linear Dimension tool.
3. If it is not already set, right click and select *Dim Mode : Cumulative* from the popup menu.
4. Click on the first line or the start and end points for the first dimension of the chain, and then click where you want to place the dimension line.
5. Snap to the endpoints of the remaining lines and then place the dimension lines.
6. Right click and select *Pen Up* to end the command.

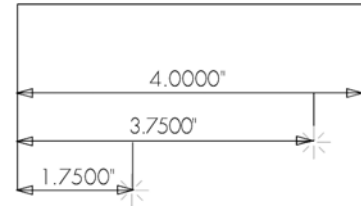

### To Dimension an angle:



1. Click the Angular Dimension tool.
2. Click the arc or the three points that define the angle.

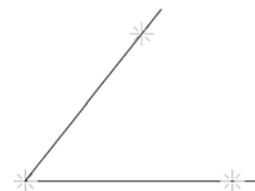

3. Drag the cursor and then click where you want to place the dimension arc.

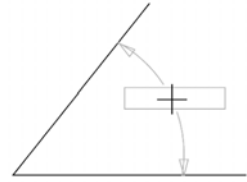

**To dimension the radius of an arc or circle:**



1. Click the Radial Dimension tool.
2. Click on the circle or arc that you want to dimension.

3. Drag the cursor and click where you want to place the dimension.

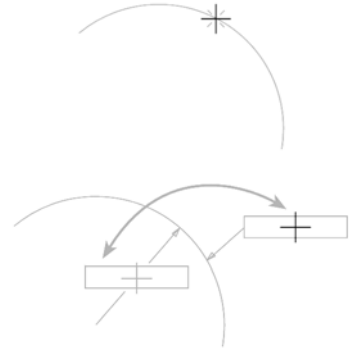

**To dimension the diameter of an arc or circle:**



1. Click the Diameter Dimension tool.
2. Click on the circle or arc that you want to dimension.
3. Drag the cursor and then click where you want to place the dimension.

**To dimension a series of offsets from a basepoint:**



1. Click the Ordinate Dimension tool.
2. Snap to establish a basepoint from which to measure the subsequent dimensions. In this example it is the lower right corner of the window sill.
3. Drag the cursor in the direction that describes the positive axis of your measurements and click to set the direction. A rubberband appears with the first dimension. Drag it to the desired location and click to set.
4. Snap to or click the points that you want for the remaining dimensions, then right click and select *Pen Up* to finish.

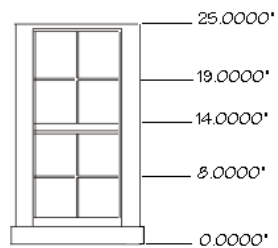
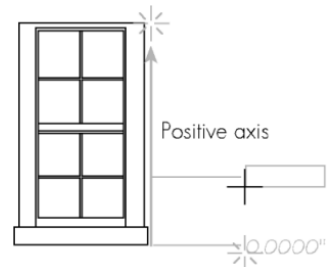



### To create a datum dimension

1. Click the Datum Dimension tool.
2. Snap to or click the point to dimension.
3. Click additional points to draw the leader, right click, and then select *Pen Up* to complete the leader line.
4. Press [OK] on the speedbar or press ENTER twice to place the datum text and complete the command.
5. If you want to flip the datum text before completing the command, as shown in the illustration at right, click on the dimension, drag the cursor left or right, click again, then [OK] or double ENTER.

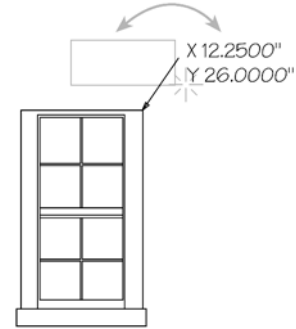

### To Place Multiple Dimensions

1. Select the number of lines you want to dimension and then start the Multiple Dimension command from the Draw>Dimension menu or type **MM**.
2. The first dimension will appear with a prompt to place it. The cursor will then 'jump' to your next selected line and prompt you to place a dimension.
3. Continue placing dimensions. The command will end when you've placed the dimension of the last selected entity.

To get an idea how the tool works, draw a rectangle, use a *selection window* to select the entire rectangle, type **MM**, and place dimensions as prompted.

---

**Tip** When placing a dimension, the Dim String tab on the speedbar shows the current actual value of the dimension. You can overwrite this value. After starting the dimension, tick the overwrite dimension checkbox in the speedbar, then type in a new dimension value. Clicking OK or pressing ENTER key updates the value and closes the speedbar. Finish placing the dimension with a left mouse click.

---

## Modifying Existing Dimensions

---

In addition to modifying the properties associated with a dimension, you can also move dimension lines and text.

To find the commands for modifying dimensions, right click after you select the dimension that you want to change. The options will vary according to the type and number of dimensions you select.

### To modify dimension properties:

1. Select one or more dimensions that you want to edit.
2. In the drawing area, right click and select *Dimension Edit*, or type **ED**.
3. Modify the dimension properties that you want to change and click [OK].

### To move dimension text:

1. Select the dimension.
2. In the drawing area, right click, and then select *Dimension Text Move*.
3. Drag and then click where you want to relocate the dimension text.

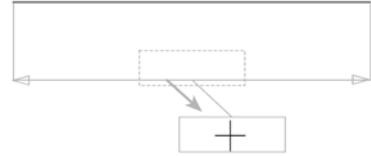

### To slide dimension text along a dimension line:

1. Select a linear, ordinate, diameter, angular or radial dimension.
2. Right click, and then select *Dimension Text Slide*.
3. Slide the dimension text along the dimension line, and click where you want to relocate it.



### To move a dimension line:

1. Select a linear dimension.
2. Right click, and then select *Dimension Line Move*.
3. Drag and then click where you want to relocate the dimension line.

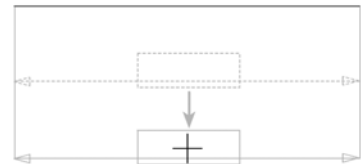

### To move a dimension arc:

1. Select an angular dimension.
2. Right click and then select *Dimension Arc Move*.
3. Drag and then click where you want to relocate the dimension arc.

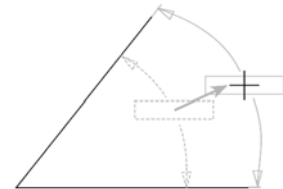

## Adjusting Dimension Settings

---

Dimension settings control dimension and extension lines, dimension text, and numeric formats. Adjusting dimension settings enables you to match dimension objects to your drafting standards. Each element of a dimension can be modified individually.

Because Visual CADD works in real-world scale, consider your final output when adjusting dimension text and elements. Set the size of properties such as text and arrows so that the elements are legible when they are scaled for printing.

If you place all dimensions on one layer, you can easily control when dimension information is visible or printable.

# Anatomy of a Dimension:

## Mode

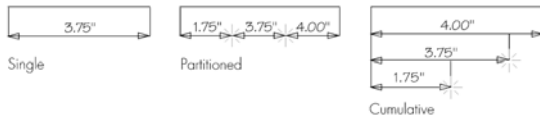

## Text Alignment

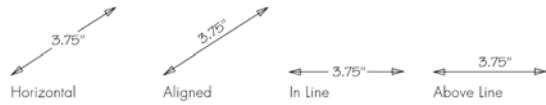

## Extension

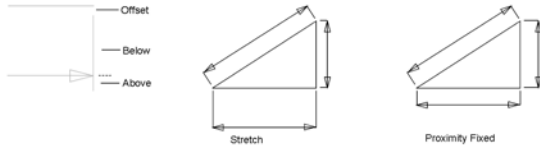

## Arrow Types

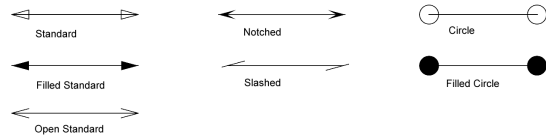

## Prefix/Suffix

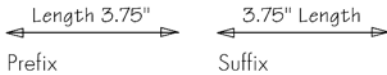

## Tolerance

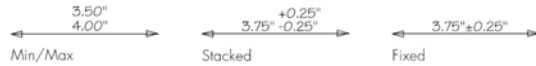

# Dimension Settings

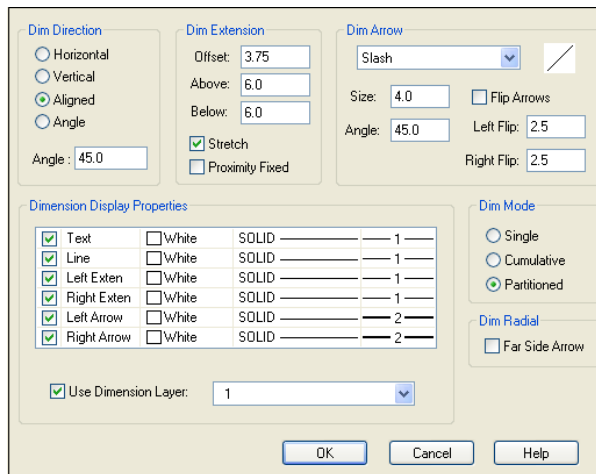

This section provides a general explanation of the settings on the Dimension dialog. For more detailed and specific info about each setting please see the Help file.

## Direction options

The dimension direction is the orientation used to measure a distance when adding dimension lines. This direction is usually but not always aligned with the object being dimensioned. Measured distances on an object can be projected onto the

dimension direction. For example, the horizontal dimension of a line drawn at a thirty degree angle represents the horizontal component of the true length of that line. The actual length of the angled line will be longer than the horizontal dimension.

The four direction options are Horizontal, Vertical, Aligned and Angle. The first two constrain the dimension to the stated orientation. Aligned sets the dimension direction to parallel the object selected or the points at each end of a line or other object you snap to. Angle sets the dim line to a specific angle you choose, regardless of the angle of the line or other object you are dimensioning.

### Arrow options

Visual CADD has 7 different arrow types, as shown in the illustration on the previous page. Note that Leaders, discussed later in this chapter, have the same arrow choices, and that the Dimension and Leader arrow types can be set independent of each other.

You can set both the size and angle of most arrows (the circle options don't have an angle).

The Flip Arrows option flips or reverses the dimension line and the arrows so that they are outside the extension lines. Use this option when you have a short dim string and need more room to display the dimension text between the extensions.

The Left Flip and Right Flip options set the length of the dimension line segment outside the extensions when the arrowheads are reversed.

---

**Tip:** Many users set the arrow size the same as the text size.

---

### Extension options

Extension lines visually connect the ends of the dimension line to the object being dimensioned. They are always drawn perpendicular to (and usually beyond) the dimension line. Extensions typically have an *Offset* that creates a space between the end of the extension line and the object being dimensioned.

The *Above* setting adjusts the distance that the extension extends past the dimension line and away from the drawing object.

The *Below* setting adjusts the distance of the extension from the dimension line and towards the drawing object, when *Stretch* is unchecked.

When *Stretch* is checked, the extension lines stretch to reach the drawing object (minus the Offset distance). When unchecked, the Offset setting is ignored, and the extension lines follow the setting of the Below distance.

*Proximity Fixed* when checked places the dimension line at a fixed distance (Offset plus Below) from the drawing object.

With *Proximity Fixed* unchecked, you can place the dimension line at any distance away from the object by dragging it with the mouse before setting it with a left click. This means that either the Offset distance or the Below distance must "give." If *Stretch* is checked, the Below section of the extension line will stretch to fill the gap

between the Offset distance and the dimension line. If Stretch is unchecked, the Below distance will remain constant and the Offset distance will "give" to fill the gap.

### Mode options

There are three mode options: *Single* places one dimension and ends the command. *Cumulative* places a sequence of dimensions, each originating from the first point. *Partitioned* places a string or chain of connected dimensions, placed end-to-end.

An ESC or *Pen Up* is required to end the Cumulative and Partition options.

### Display options

The elements that make up each dimension include the dimension line, left and right extension lines, left and right dimension arrows, and the dimension text. Visual CADD gives you total control over the visual properties of each dimension element independent of the others. Changing the properties of dimension elements will not affect previously drawn dimensions.

Visual CADD 6 introduces a tree control for setting dimension display options. Single click anywhere on a line to select an element, then click again to dropdown an arrow to change settings for each element. Untick the checkbox if you do not want to display an element of a dimension.

Select all elements in the tree by selecting the first item in the list, hold down the SHIFT key, and click on the last item. Hold the CTRL key and left click to select only some of the items in the tree. An example: if you want to change the line width of the arrows, select Left Arrow, hold CTRL key and select Right Arrow, then from the line width dropdown of either arrow change the setting, and it will change for both arrows.

### Dim Radial

**Far Side Arrow** - for Radial dimensions where the dim is placed outside of a circle or arc, this gives you the option of having the arrow point to the far side. For example, draw a circle and place a radial dim outside the circle. It will look much like a Leader. Select the dimension and type either ED or DE to open the Dimension Edit command. Tick the Far Side Arrow checkbox and ok to close the dialog. The dimension line and arrow has stretched to the far extent of the circle.

### Layer

By default dimensions are placed on the layer that is current in a drawing. If the *Use Dimension Layer* box is checked, Visual CADD will maintain a separate layer for dimensions, independent of the current layer.

The drop-down list to the right of the checkbox is used to choose the layer on which dimensions will be placed.

# Dimension Text Settings

Click on *Settings* in the Utilities menu, then click on the Dimension Text dialog option to change settings.

## Text Settings

Sets standard text characteristics for dimensions. Visual CADD supports both TrueType and vector fonts, and some settings will apply to one type and not the other. See the Help file for more specific information on each item.

## Dimension Text Offset and Placement Options

You can place dimension text to be *horizontal*, regardless of the angle of the object and dimension line, or always *aligned* parallel to the dimension line.

The Vertical Position options define where the dimension text sits in relation to the dimension line. *In-Line* places the text in the dimension line, and *Above-Line* always places the text directly above the dim line, no matter the angle of the dimension.

*Outside* specifies that dimension text is placed parallel to the dimension line, but never between the dim line and the object being dimensioned.

The *In-Line Distance* sets the offset distance of the dimension line from the text. *Above Distance* sets the offset of the text above the dim line.

*Centered* places the text at the midpoint of the dimension line. Unchecked, you can drag the text with the mouse and left click to place it at any point on the line.

When *Alt Rotate* is checked, dim text on aligned or angled dimensions will be rotated as necessary so when printed output is read from the right side, no dim text will display "upside down".

## Dimension String & Prefix/Suffix

Checking the *Overwrite* box replaces the calculated dimension text with text that you type in the adjacent edit box. Dimension text is no longer associative if you stretch the objects(s).

The Prefix/Suffix options let you add a custom prefix and/or suffix to the angle or distance that Visual CADD calculates, without losing the associative property of the dimension. This text is placed on the same line as the dimension text.

You can edit a dimension after it is placed so that the suffix text is displayed on a separate second line below the dimension text and dimension line. Use the text settings on the Edit dialog to further change the suffix, for example to center text under the dimension string or increase the line spacing.

### Tolerance options

Tolerances specify allowable variations in dimensions, and are often used in high-precision work. Visual CADD lets you specify and display tolerances, with four choices: Basic, Min/Max, Stacked and Fixed. The Basic option draws a box around the text. For an illustration of the other three, see the illustration earlier in this chapter. **Text Settings** - sets standard text characteristics for leaders. See the Help file for more detailed information.

### Other Options

**Dim Scale** - sets the factor by which dimension values are scaled from the standard drawing units. Used when details or drawings of mixed scales are plotted on the same sheet. This factor allows details to be enlarged beyond real-world size, and dimensioned correctly without having to reset size-related dimension properties.

**Distance/Angle Display** - new in v6, it sets the display of the dimension text with regards to distance and angle. There are four options. The first is *Default*, the legacy setting from earlier versions, and it varies depending on the dimension command. For example, default for Linear Dimension is the distance, and the default for Angular Dimension is the angle.

The fourth option, *Opposite of Default*, flips these settings. A Linear Dimension will show the angle rather than distance. An Angular Dimension will show the length of the arc rather than the angle.

The second and third options are Angle then Distance and Distance then Angle. These are used when you want to show both the distance and the angle as part of the dimension text string. Note that Visual CADD 6 adds several new choices to the existing Angular Format on the Numeric dialog, including Surveyor, Radians and Grads.

**Flip the Reference** - toggles the angle in the setting above to its opposite state. This can be useful if you are placing surveyor labels. For example, toggle between N23:34:45W and S23:34:45E, or 44 degrees and 224 degrees.

---

**Note** Dimensions also have numeric settings that affect their appearance in a drawing. Settings include the unit (for example, inches or millimeters), number of decimal places, and the format for display of angular dimensions. For complete details, see *Numeric Settings* in Chapter 3.

---

**Tip** You can save dimension settings as a Style and then retrieve them to quickly adjust all settings for the next dimension you will place. See Chapter 4 for more information.

## Drawing Leaders

A *Leader* is an arrow and lines with a text string attached, and allows you to visually connect text information to drawing objects and/or assemblies.

Use leader settings to adjust the arrow, line and text properties of the leaders in your drawing. Leader settings also control the format of datum dimensions.

Because of the new Settings dialog introduced in version 6, along with some new Leader features, Leader Settings has been expanded from a single dialog to two: *Settings*, dealing with arrows and lines and display properties; and *Text*, where you set font, height, alignment and other Leader text settings.

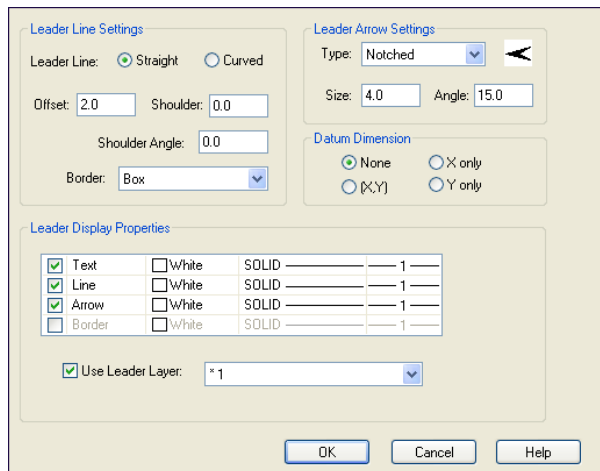

### Leader Settings

Click on *Settings* in the Utilities menu to open the dialog.

**Leader Line Settings** - choose a straight or curved leader line, and set options for offset to text and length and angle of the shoulder, illustrated below. A new v6 feature lets you draw a border around the leader text.

**Leader Display Properties** - A new v6 feature gives you total control over the visual properties of each leader

element independent from the others. Tick the checkboxes to control display of text, line, arrow and border, and specify different color, linetype and linewidth for each if desired. Tick the User Leader Layer checkbox and select the layer if you want all leaders to be placed on a single layer.

**Leader Arrow Settings** - sets the type, size and shape of the arrowhead. In the illustration at right, note the the shoulder that is discussed in the leader line section above.

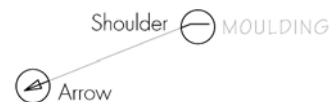

**Datum Dimension** - instructions for placing a datum dimension were described earlier in this chapter. Click on a button to set the datum dimension style to display X values, Y values, both or none.



### To draw a leader:

1. Click the Leader tool or type **LE**.
2. Click the start point for the leader. This places the leader arrow.
3. Click additional points to draw the leader line, then right click, and select *Pen Up*.
4. Type the leader text and it will appear onscreen as well as in the speedbar. Click [OK] or press ENTER twice to complete the command.  
If you want to flip the leader text before completing the command, click on the leader, drag the cursor left or right, click again to set it, then [OK] or double ENTER.

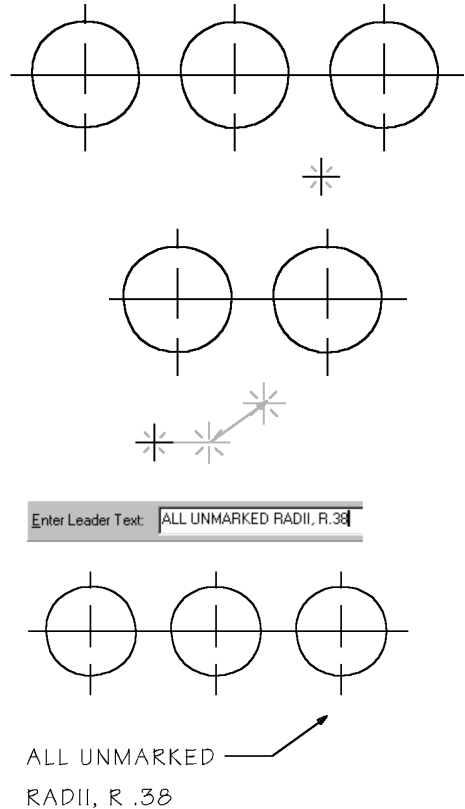

### To reshape a leader:

1. Select Modify>Move Point.
2. Click anywhere on the leader line, and then click the point that you want to move.
3. Click the new location of the point.

### To flip text of an existing leader:

1. Select an existing leader in the drawing.
2. Type **LE** or click the Leader tool on the toolbar.
3. Click on the leader, drag the cursor left or right, click again to set it, then [OK] or double ENTER.

### Tip

To modify a leader in the drawing, select it, right click and click *Leader Edit* to bring up the edit dialog. Or right click and click *Leader* (or type **LE**) to edit the text onscreen and change settings from the speedbar tabs. Changes made to the speedbar will update onscreen in real time.

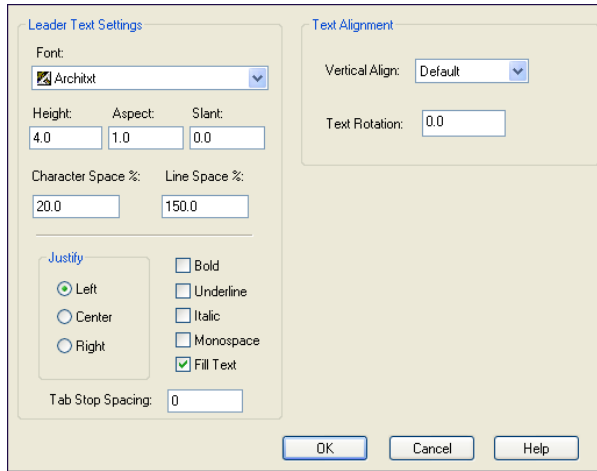

## Leader Text Settings

Click on *Settings* in the Utilities menu to open the dialog.

**Text Settings** - sets standard text characteristics for leaders. See the Help file for more specific information on each item.

**Text Alignment** - the *Vertical Align* option determines the relationship of the leader shoulder line to the text. Use it on a leader with multiple text lines to control the appearance

of the text.

*Text Rotation* is a new v6 feature, and determines the angle of the text to the shoulder line, Note that you can also set a shoulder angle on the Leader Settings dialog, so it is possible to have both leader text and shoulder line at the same angle to the main leader line. An illustration of these new features is shown at right.



## Making Measurements and Getting Object Information

### To measure the distance between two points:

1. Select Utilities>Measure Distance & Angles.
2. Select two points, and then read the distance from the speedbar.

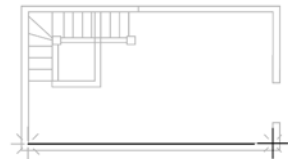
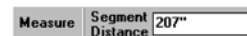

### To measure the distance along a perimeter:

1. Select Utilities>Measure Distance & Angles.
2. Select points along the perimeter, and then read the distance from the speedbar.

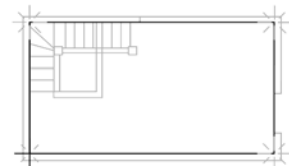

### To measure the angle between two points:

1. Select Utilities>Measure Distance & Angles.
2. Select two points defining the line, and then read the angle from the speedbar.

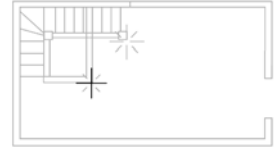

### To measure the angle between two lines:

1. Select Utilities>Measure Distance & Angles.
2. Select three points defining the angle to measure, and then read the angle from the speedbar.

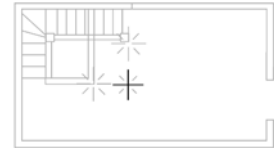

### To measure the area of a region:

1. Select Utilities>Measure Area.
2. Select the points defining the perimeter of the area to measure, and then read the area from the speedbar.

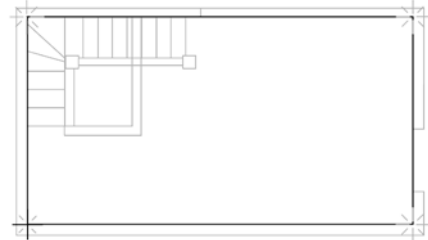

---

**Tips** Use the snap commands to place accurate points when measuring distances, angles and areas.

To avoid selecting more points than you want when measuring an area, hide layers that aren't needed, or make the layer you are measuring the current one, then type **AL** to toggle *All Layers Off* so that you can only pick objects on the current layer.

---

## Basic Information About an Object

---

### To see basic information about an object:

1. Select an object and place the cursor over it.
2. Read the information displayed on the status bar.

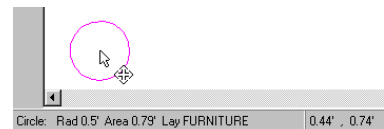

The information will vary depending on what type of entity is selected. In all cases you will see the name of the object type and the layer it is on. In the illustration above a Circle also shows radius and area. Other examples: a Single Line will show length

and angle; a Text block shows font name, height, rotation and justification; and a Hatch object will display the hatch name, length of perimeter, area and hatch scale.

## Getting Additional Information About an Object

The Object Information window opens when you select Utilities>Object Info or type **OI**.

The Object Information window displays the order of each selected object in the drawing database, the coordinates of points, the lengths of segments, the object's area, and all object properties. For example, the object information for a circle includes not only coordinate data, layer, color, linetype and linewidth, but radius and diameter as well. The information for text includes its starting point, font, font height, justification and character spacing.

If no entities are selected, the Object Information window displays information about the current drawing window, such as the total number of entities in the drawing (including deleted entities available from memory for undo operations), valid (undeleted) entities in the drawing, and the extents of the drawing, with coordinates of the lower left and upper right corners.

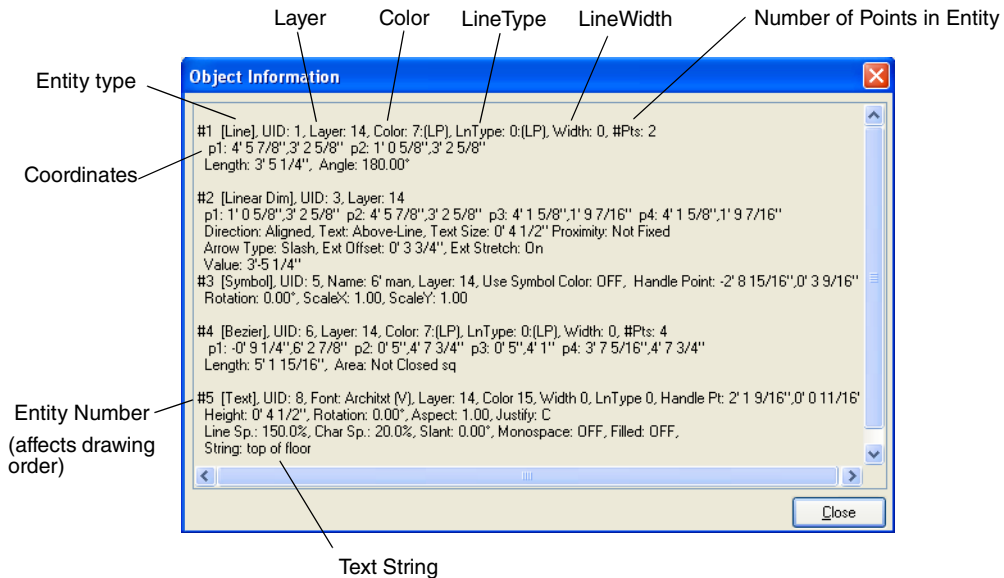

Information from this window can be copied and pasted into other Windows applications. Select the desired text, right click and choose Copy.



## WORKING WITH TEXT

Text has many uses in a drawing. For example, you might use it to clarify details and label objects, provide building specifications, or to create title blocks,

Visual CADD offers an easy to use set of tools for creating and modifying text, importing text from other applications, checking spelling, and converting AutoCAD and Generic CADD fonts into Visual CADD vector fonts.

Each block of text that you add to a drawing has properties that define its appearance such as font, size, angle of rotation, color and layer. You can set these properties before you create the text or while you are creating it, and you can edit both the properties and the text string after you have added it to the drawing. Text properties apply to all text within a text block rather than individual characters.

Visual CADD ships with a number of vector fonts that are optimized for plotters and other vector output devices. Although the TrueType fonts supplied with Windows tend to redraw faster than vector fonts, they are less accurate and can cause problems with many older output devices.

Some text elements of your drawing require specialized tools. Dimensions, Leaders, and Attributes include text, but you use dimensioning and attribute commands rather than text commands to create and edit them.

### Adding Text to a Drawing

---

Two different text tools are available: the Text Line and the Text Editor. Both tools allow you to place and edit text, but they do so in very different ways.

The Text Line tool displays text onscreen in real time while you type (as well as one line at a time in the speedbar). You edit already placed text while viewing it onscreen.

The Text Editor tool opens a dialog that displays multiple lines of text along with their associated settings. This tool is good for editing longer text blocks. The Text Editor tool also provides an option for importing text from sources outside Visual CADD.

While using either tool, you can adjust properties at any time. Properties can also be set before using either tool by selecting *Settings* from the Utilities menu and then the Drawing>Text dialog.

## Working with Text

You can set Visual CADD to place all new text blocks on the current layer, or on a specific text layer regardless of the active current layer. You can also choose to set any combination of text color, linetype and linewidth settings to be either on the current layer or a specific layer you choose.

### To set the properties display of text blocks:

1. Select Utilities>Settings.
2. In the Settings dialog, click the Drawing>Text option.
3. Change settings for *Text Display Properties* as desired by clicking the arrow and selecting from the dropdown list for each of the four properties. Selecting <current> means that the text will take on the property that is current in the drawing when a text block is placed.

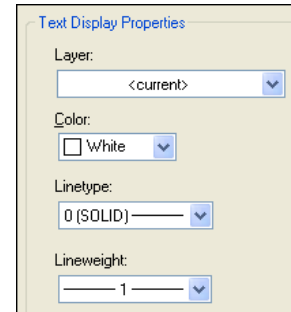

## Placing Text in Your Drawing

### Drawing Scale and Text Size

Because text size is in real-world units, you will need to adjust it to be legible when printed, especially at smaller scales. For example, if text height is set at 4 and Numeric units to inches, text will print 4” tall on paper when the output scale is 1:1. If scale is 1:48 (1/4”=1’), text will print at 5/64” (4 divided by 48). This size is legible for general text at the 1:48 output depending on the font used. A bit of experimenting will help you decide the best text sizes for your output.

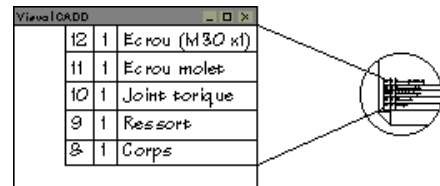

### Cursor Size

When you select a starting point for your text, the cursor becomes an I-beam. The size of the I-beam represents the actual size of the text. If you zoom in too far, the I-beam is too big to fit on the screen. If you zoom out too far, the I-beam appears as a tiny dot on the screen. Zooming in or out will make the text appear at a more manageable size.

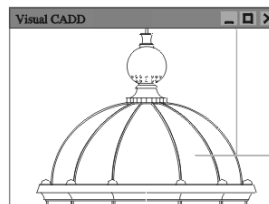

Text (represented by the I-beam) is too large when zoomed in too far.

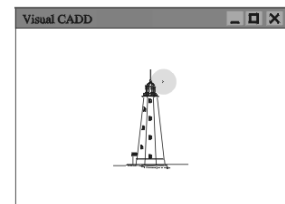

Text is almost invisible when zoomed out too far.

# Setting Text Properties

---

You can set text properties from several different places: on the Text Editor dialog, in the Text dialog accessed from the Utilities>Settings menu, and from the speedbar at the top of screen after starting the Text Line tool.

The two dialogs may be a better choice if you are making wholesale changes to text properties, because all settings are visible in one place, whereas with Text Line you will have to click a few different tabs to access all settings. But the Text Line tool offers one powerful feature the others don't have: changes are updated onscreen in real time. If your text height is set to 4" and you change it to 8" on the speedbar while placing text, it doubles in size onscreen. If you change the rotation to 45 degrees, the text rotates immediately when you click in the drawing after typing in the change.

Below we will look at setting text properties on the Text Line speedbar tabs, but as mentioned all these settings are available on the other dialogs.

## Text Line Tab



This tab opens when you start the Text Line tool and left click to place the insertion point for the text block in the drawing. As you type, text will appear in the edit box as well as onscreen. If you click the match button  on the right side of the bar, and then click on another text block in the drawing, all properties of that text block will be applied to the new text line.

## Text Settings Tab:

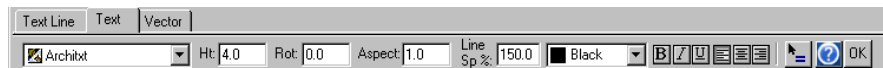

The Text Settings tab contains some settings that affect text placed with all fonts and other settings that affect only text created using a TrueType font.

**Font** - sets the font of the current text block from the dropdown list.

**Height** - sets the height of the text.

**Rotation** - adjusts the rotation angle of the text block.

**Aspect** - adjusts the height-to-width ratio of characters. An aspect of 1.0 yields characters that are as tall as they are wide and is the default setting.

**Line Spacing** - sets spacing between text lines as a percentage of the text height. For example, 200% yields double spacing.

**Color** - sets the color of the text block from the dropdown menu.

**Format** - with TrueType fonts, adds Bold or Italic. With both TrueType and vector fonts, adds Underline to the text block.

**Justify** - sets the alignment of the text to left, center or right.

## Vector Settings Tab:



The Vector Settings tab contains settings that affect text placed with a vector font.

**Character Spacing** - spacing between characters, as a percentage of character size, 100% creates one full character width between each character in the text block.

**Slant Angle** - similar to italics in a True Type font, except that you can slant text to any degree and also backwards by entering a negative number.

**Fill Text** - when unchecked, characters are displayed in outline, which makes redrawing and printing faster. Does not apply to single stroke vector fonts.

**Monospace** - when checked, all characters are the same width, Unchecked, wide characters (M, W) take up more space than narrow ones (I, L).

The match button on these last two tabs works a bit differently than on the Text Line tab. Click the button on the speedbar, click in one of the edit boxes or dropdowns, then click on a text block in the drawing to match *only* that one property. For instance, clicking in the Rotation box on the Text Settings tab, then on a text block in the drawing, matches only the rotation angle while leaving all other properties unchanged.

### To create a short text block:

1. Click the Text Line tool, then click in the drawing to place the start of text line.
2. Type the text. It will appear in the drawing and in the speedbar.
3. Press ENTER once to start a new text line.
4. Hold down the CTRL key while pressing ENTER twice if you want to insert a blank line and then begin a new paragraph.
5. When done typing text click [OK] or press ENTER twice to finish the command. The cursor must be at the end of the text block to use the double ENTER.

### To create a longer text block:

1. Click the Text Editor tool.
2. Click where you want to locate the text in the drawing.
3. In the Text Editor dialog, type the text to be added. Adjust properties if needed. Click [OK] to complete the command and close the dialog.

See the *Text Editor* topic in the Help file for more detailed information on the settings at the bottom of this dialog.

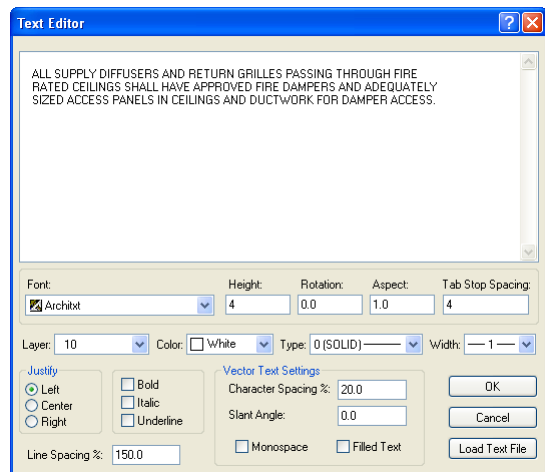

---

**Tip** To see cut, copy, and paste functions inside the Text Editor tool, right click inside the large text box area of the Text Editor dialog.

---

## Modifying Text

---

When modifying existing text, you can change the text string, the properties of the text block, or both. The same tools that you use to create text are also used to modify it.

### Choosing a Tool to Modify Text

Often the Text Line tool is used to modify shorter text blocks, while the Text Editor is used for longer blocks. The main reason is that on the Text Editor dialog you can navigate quickly through large amounts of text using the scrollbars or scroll wheel as well as the mouse to jump to different sections, or to highlight a portion of the text to copy or delete.

With Text Line, you can edit text directly onscreen and see the results in real time, but are limited to keyboard navigation with the arrow keys, Backspace, and Home and End.

If you are changing properties such as text height or rotation, using Text Line will show you those updates on the screen in real time. With Text Editor, you make changes in the dialog and updates are not applied until you click [OK].

Both tools apply to a single text block that you have selected. If you select 2 or more text blocks, the Text Change command is used instead. With multiple selections you can change text properties but not the text string itself.

#### To modify a short text block:

1. Select the text block that you want to modify.
2. Click the Text Line tool.
3. In the text speedbar, make changes to the text properties. Modify the text string directly onscreen or in the speedbar edit box.
4. Click [OK] on the speedbar or press ENTER twice to finish. If you use ENTER to end the command, the caret (cursor) must be at the end of the last line of the text block.

#### To modify a longer text block:

1. Select the text block that you want to modify.
2. Click the Text Editor tool.
3. In the Text Editor dialog, make changes to text and properties.
4. Click [OK] to finish.

## To change the properties of multiple text blocks:

1. Select the blocks of text that you want to modify, then click the Text Change tool from the Draw menu or the side toolbar. You can also type **ED** to open the dialog. Edit (**ED**) is a powerful command, as it will open the relevant dialog of any object you select to modify.
2. Modify the text properties and click [OK].

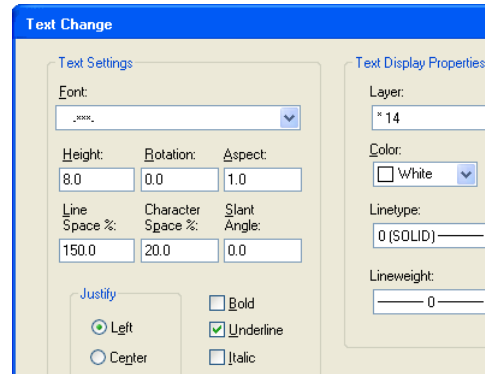

---

**Note:** The Text Change dialog displays the symbol -\*\*\*- when the properties for a particular text setting are different among the selected text blocks.

---

## Checking Spelling

---

You can check the spelling of text blocks and leaders in your drawing. By default all of the text and leaders in the drawing are spellchecked when you run the command. If you instead select one or more text blocks or leaders, *only* those selections are checked.

Text blocks and leaders within a symbol, and text that is part of an overwritten dimension, are not spellchecked.

Start the command from the *Utilities* menu or type **SK**, and a dialog pops up when the spellchecker first encounters a word that is not in a Visual CADD dictionary. The word is displayed in an edit box at the top of the dialog. There are several choices at that point: you can ignore the message and retain the spelling, add the word to a custom dictionary, or change the word to one in the Suggestions list. If the list doesn't contain the word you want, type it directly into the top edit box.

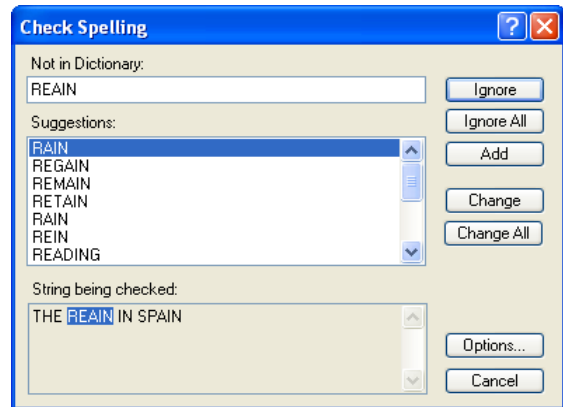

**Spelling Options** allows you to specify various choices, such as how to handle words that begin with a capital letter or words that contain *only* capital letters. You can also change to a main dictionary in a different language if alternates are shown in the dropdown list (if not you can check the Support section of our website to see if there are others available for download). The Spelling Options dialog can be called up from the main spellcheck dialog or directly from the Utilities menu. A complete description of each option can be found in the Help file.

## Editing the User Dictionary

---

When the spellchecker encounters a word that is not found in one of the supplied dictionaries, it gives you the option of clicking the [Add] button. When you do so the word is added to a custom dictionary and is “remembered” in all subsequent documents that you spellcheck.

You can directly edit this custom dictionary by clicking on the [Edit User Dictionary] button on the Spelling Options dialog.

Pressing the button opens a dialog with a scrollable list of all words in the dictionary. You can add a word directly to the list by typing it in the top edit box and clicking [Add Word]. Delete a word by selecting it from the list and clicking the [Delete Word] button.

Use the [Import] button to add the contents of a .txt file to your custom dictionary. All words in the file will be added to the list. Press the [Export] button to save the contents of your dictionary to an external .txt file.

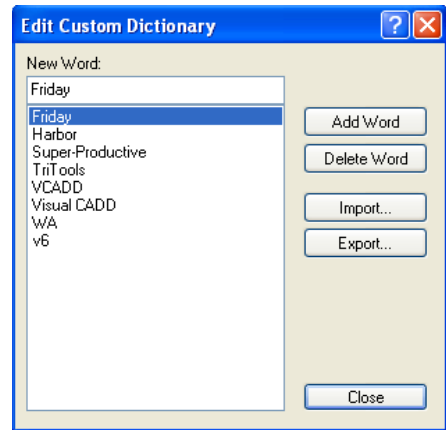

## Choosing Fonts

---

In Visual CADD, you can use two types of fonts to create text—standard Windows fonts (TrueType and printer fonts) and vector fonts. TrueType (TT) fonts redraw more quickly and appear smoother on the screen, but vector fonts have several advantages:

- **Vector fonts are accurate.** They’re defined by the same mathematics that define CADD entities. Fitting text within a particular space and aligning it precisely is easier with vector fonts. With standard Windows fonts, what prints may not exactly match what you see on the screen.
- **Vector fonts are flexible.** You can control the spacing between vector font characters, adjust the fill of the text (solid, transparent, or color), assign a slant angle (simulating italics), and choose between fixed or proportional spacing. These

options provide variations not possible with a standard Windows TrueType font. The new Font Manager gives you the option to convert TT fonts to Vector on-the-fly to use these features in Visual CADD drawings.

- **Vector fonts are predictable.** Some plotters and other output devices that use a shape description language—such as PCL—make a reasonably accurate representation of standard Windows fonts. Those using a vector language—such as HP-GL/2—attempt to assign each Windows font to an internal plotter font, which can have unpredictable results. To avoid discrepancies, use vector fonts in your drawing, and the vector output device will plot them accurately.

Visual CADD comes with a number of vector fonts, including several filled fonts that emulate TrueType fonts.

## Types of Fonts



Visual CADD vector fonts. Slant is user defined.

TrueType fonts. Slant is typeface defined.

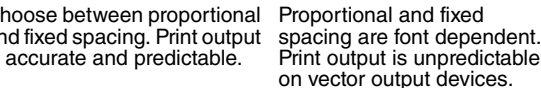

Choose between proportional and fixed spacing. Print output is accurate and predictable.

Proportional and fixed spacing are font dependent. Print output is unpredictable on vector output devices.

## Font Manager

---

Visual CADD 6 introduces a Font Manager to better control font settings in your drawings. You can control the fonts that are listed in the font list. You can designate a few fonts as your favorites so that you don't have to wade through all of the Windows fonts to find the ones that you want. You can choose to display only vector fonts (VCF) or TrueType fonts.

Fonts used in a drawing are always shown in the list, whether VCF or TT, so you can find out what fonts are used in a drawing by clearing the three filter checkboxes at the top.

All of the columns on the dialog can be sorted by clicking on the column headers.

### Displayed Fonts

There are three choices. Favorites are the fonts you select. The other options will display all the TrueType fonts and/or Vector fonts.

## Draw TrueType fonts as Vector fonts

Visual CADD 6 can convert TrueType fonts to vector fonts on-the-fly. That means that you can use a TT font and still take advantage of some of the font features that are specific to VCF vector fonts. To enable "Draw as Vector" for a TT font click on No in the Vector column so that it changes to Yes.

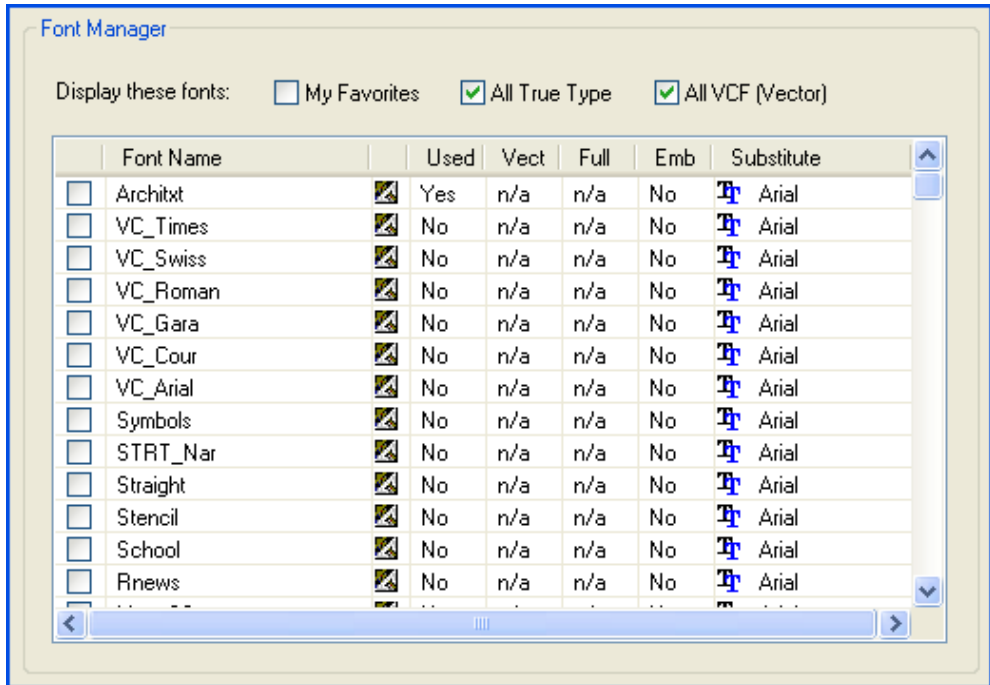

## Draw TrueType Fonts at full height

Visual CADD does not draw TrueType fonts at their full nominal height, which causes a slightly different appearance in drawings. Visual CADD 6 has an option to draw a TrueType at full height. Click on the *Full* column to change the setting to Yes.

## Embed VCF fonts

VCF vector fonts can be embedded in drawings so that the VCF font files don't need to be shipped when sharing drawings with others. Click Yes in the column to embed the fonts with a drawing.

## Substitute font

Earlier versions of Visual CADD always substituted the Arial font when a missing font was encountered. In Visual CADD 6, you can specify both the type and name of the font to be used as a substitute. Click on the font type icon under Substitute to toggle it. Click on the Substitute name to choose the substitute font from a list.

The font filtering feature of the Font Manager is useful, but there are occasions when you may want to use a font that is filtered from the list. To avoid having to go to the Font Manager to change the filter settings, you can right-click on the font list combobox in any of the text/font dialogs. A popup menu will appear with both the filter settings and the sort order.

## Converting AutoCAD and Generic CADD Fonts

---

You can add more vector fonts to your system by translating fonts created for use with AutoCAD or Generic CADD.

If you have AutoCAD or Generic CADD vector fonts and want to use them with Visual CADD, you can use the Font Converter to create a vector font in the .vcf format. The Font Converter converts AutoCAD font files (.shx) or Generic CADD font files (.fnt), but it cannot convert AutoCAD's big-font files.

### To convert an AutoCAD or Generic CADD vector font:

1. Select Utilities>Font Converter.
2. From the Files of Type list in the Font Converter dialog, select the type of file that you want to convert.
3. Select the font files to convert, and then click [Open].

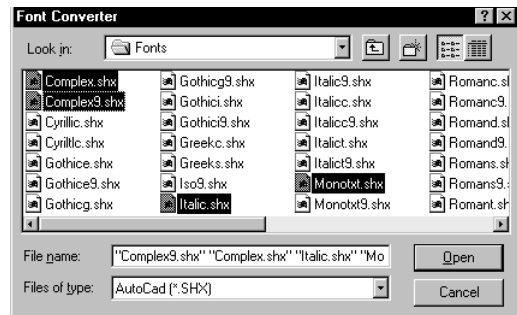
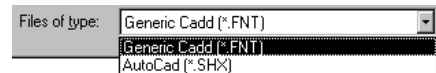

**Note** The VCADD 6 Font Converter does not support Unicode fonts. Most .shx fonts in later AutoCAD releases are Unicode and will not convert. You can find earlier versions (R12) of most .shx fonts with the same name at the various AutoCAD shareware sites on the Internet.

---

# SYMBOLS AND HATCHES

Symbols are a group of objects you can insert repeatedly in a drawing. They save you from having to draw the same objects over and over. You can create new symbols and add them to Visual CADD's symbol libraries, or modify existing symbols. You can create and attach Attributes as text information associated with a symbol.

Hatch patterns and fills give texture to a drawing, and help objects or assemblies stand out from surrounding objects, making them easier to identify.

## Using Symbols to Keep Drawing Elements Together

---

Symbols have advantages beyond not having to always draw the same thing:

- Using symbols can reduce the file size of your drawing. Each symbol is defined only once in the drawing database, even when you insert it at different sizes and at different angles.
- In one step, you can delete all occurrences of a symbol in your drawing, or replace all occurrences of one symbol with another.
- You can attach attributes to a symbol (for example, manufacturer, model number, and size of equipment).

You can apply the current color to a symbol as it is placed, but you can't change the line type or width unless the symbol is exploded. You can choose to explode a symbol into its individual components as it is placed. You can then edit these objects, but you can't attach an attribute to an exploded symbol. Exploded symbols also enlarge the drawing file.

### Using Symbols in your Drawing

Use a symbol as a company standard detail. A project team can work with a single library of symbols to standardize drafting conventions.

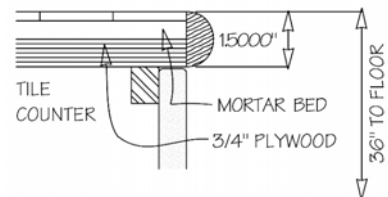

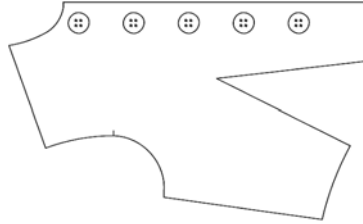

Use a symbol to group a collection of objects that you draw frequently.

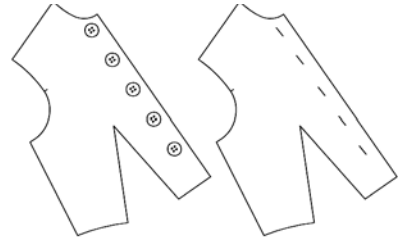

Use a symbol to search for and replace an existing symbol.

## Symbol Manager Options

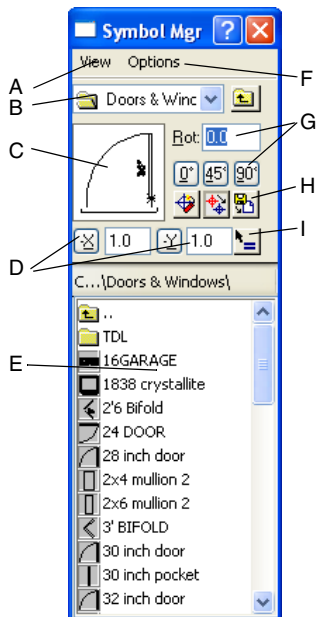

Open the Symbol Manager from the main toolbar or the *Symbols* menu. Use the manager to drag and drop an existing symbol directly into your drawing, or create a new symbol by selecting a group of objects in the drawing and dragging them into the Symbol Manager.

**A** - the View menu provides options for changing the icon view in the Symbol Manager list, and lets you view already loaded symbols or symbols on a hard drive.

**B** - with *Symbols on Disk* option selected in the View menu, shows the selected folder containing symbols.

**C** - previews a symbol selected from the symbol list.

**D** - sets the size of the symbol when you place it. A scale value of 1.0 is equivalent to full size or 100%. A negative value flips the symbol horizontally or the -Y button to flip it vertically.

**E** -displays a list of symbols and subfolders if they exist in the selected folder.

**F** - the Options menu provides several choices for specifying the behavior of a symbol when it is placed.

**G** - sets the symbol's angle of rotation. Enter a value in the text box, or click buttons to add 45° or 90° to the current angle, or reset the angle to 0°. Positive values rotate symbols counterclockwise. Negative values rotate clockwise.

**H** - when pressed, these buttons will, from left to right, autoexplode symbols on placement, use placement color (current color), and show a view in the list of the symbols loaded into Visual CADD memory rather than those on your hard drive.

**I** - sets the angle and other properties of the selected symbol to match those of the next object you click in your drawing, before you place the symbol.

---

**Tips** Double-clicking the Symbol Manager title bar rolls the dialog up or down.

Right click in the symbol list to see different display options.

In the symbol list, double click on the Up folder icon at the top of the list to view the next folder up. If you click in the list to give it focus, the Backspace key will do the same thing. To open a folder, click on it and press the ENTER key, or double click.

---

## Placing Symbols

---

You can place symbols in Visual CADD by dragging them from the Symbol Manager into your drawing. A symbol is automatically loaded into memory when it is placed in a drawing. Any symbols that are already in an existing drawing that you open are also loaded into Visual CADD's memory. If you have multiple drawings open you can use any of these loaded symbols in any and all drawings until you exit Visual CADD .

### **To place and load a symbol in your drawing:**

1. If the Symbol Manager is closed, open it by selecting Symbol>Symbol Manager, or click the main toolbar button.
2. If necessary use the dropdown list in the upper part of Symbol Manager to navigate to the drive or folder that contains your symbols. By default this will be the *Symbols* folder the first time you use Visual CADD.
3. In the main list of the Symbol Manager, double click a folder of symbols to open a subfolder that contains symbols.
4. When you reach the desired folder, a list of symbols is displayed. Click a symbol from the list to display it in the highlight box.
5. If needed, use the controls in the top part of the Symbol Manager to rotate or scale the symbol before you place it.
6. Click in the highlight box and an outline of the symbol is attached to your pointer. Drag the symbol into your drawing to place it, using snaps and/or the Tracking command if required for accuracy.

---

**Tip** If you don't need to scale or rotate the symbol, and don't need to view it in the larger preview window, just click on the symbol in the list and drag it into the drawing.

---

## Loading Symbols

---

Symbols are automatically loaded into memory when you place them in your drawing. As an alternate to Symbol Manager, you can load symbols without first placing them by using the Symbol>Load Symbol command.

You can also choose to specify that only loaded symbols be displayed in the Symbol Manager.

### To load a symbol:

1. On the main menu, click Symbol>Load Symbol (YO).
2. Select the symbol or range of symbols that you want to load, and then click [OK].

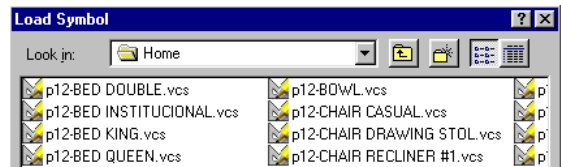

### To view only symbols that are loaded:

1. If the Symbol Manager is closed, open it by selecting Symbol>Symbol Manager.
2. In the Symbol Manager, click View>Symbols Loaded or press the View Symbols Loaded button in the Settings area at the top of the dialog.

---

**Tip** Once a symbol is loaded, you can also use Symbol Place (YP) to place the symbol in the drawing. This displays the Symbol speedbar where you can click a symbol in the picture box after selecting it from a drop-down list, and drag it into the drawing. You can also rotate and scale the symbol before placing it. The advantage of placing symbols this way is that the speedbar doesn't take up any room in the drawing area.

---

## Creating and Working with Symbols

---

### To create a symbol:

1. Select the objects that will form the symbol.
2. Select Symbol>Create Symbol (YC).
3. In the speedbar, enter a name for the new symbol, then click [OK]. The selected objects in the drawing that form the new symbol can be converted to that symbol if you check the box on the speedbar.
4. You are prompted in the status bar to enter a Handle Point for the symbol. Any of the snaps can be used to accurately place the handle point on an object.
5. The symbol is now loaded into memory. If you open the Symbol Place speedbar (YP), or the Symbol Manager and select View>Symbols Loaded, the name of your new symbol is displayed in the list.

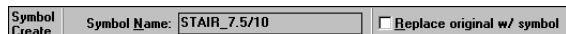

---

**Note** A Symbol Handle is the point on a symbol that is attached to the cursor when you place the symbol in the drawing. You can change this handle during placement by right clicking and selecting New Handle (or type NH), click to temporarily place the symbol, snap to a different point on the symbol, then place the symbol (typically using a snap).

---

**To Save a symbol to disk for use in other drawings:**

1. Select Symbol>Save Symbol.
2. Select the symbol from the Symbols list at the right of the dialog, and then select a folder to store it in. Select multiple symbols by holding down the SHIFT key for a range of symbols, or CTRL key to pick multiple symbols not in a range.
3. Click [Save] to finish.

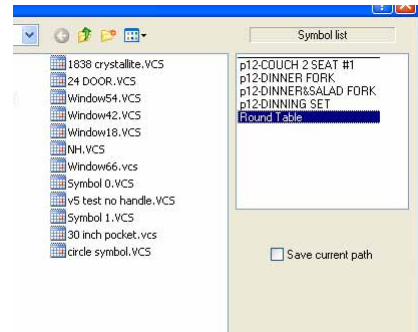

**To replace all occurrences of one symbol with another loaded symbol:**

1. Select Symbol>Replace Symbol (YR).
2. On the symbol replace speed bar, select the symbol you want to replace from the *Replace Symbol* list.
3. Select the name of the symbol you want to replace it with from the *With* list. For a symbol to be available, it must be loaded into memory.
4. Select [Replace], then click [OK].

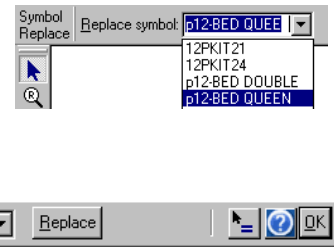

**Tips** Replace only certain occurrences of a symbol by selecting each copy of the symbol you want to replace before clicking Replace on the Symbol Replace speed bar.

To both create and save a Symbol in one step, select objects for the new symbol and drag them onto the open Symbol Manager. You will be prompted for name and handle.

To snap the cursor to any point or entity within a symbol, make sure Symbol Snap is checked on the Symbol Manager Options menu or Utilities>Settings>General.

**To explode a symbol into its basic components upon placement:**

In the Symbol Manager, select Options>Auto Explode on Placement. Now any symbol you place on your drawing will be exploded into its component parts.

**Note** Note: You can specify the layer on which to place the components of an exploded symbol in the General section of the Settings dialog. Access this dialog by selecting Utilities>Settings.

**To remove all occurrences of a symbol from all open drawings:**

1. Select Symbol>Remove Symbol (YV).

2. Select a symbol or symbols from the list, and then click the [Remove] button, *or*
3. Click the [Select Unused Symbols] button.
4. Click the [Close] button to finish.

## Creating and Attaching Attributes to Symbols

---

An attribute is textual information relating to a symbol. This information can be the model number, price, color, and manufacturer of the fitting, fixture, or equipment that the symbol represents. Only symbols can have attributes. You can display or hide attributes in the drawing.

You must either create an attribute within the current drawing or load an existing attribute file into the drawing before you can attach it to a symbol. You can attach an attribute to one symbol in your drawing, or you can embed it in the symbol definition, so that it attaches automatically each time you place that symbol.

### Parts of an Attribute

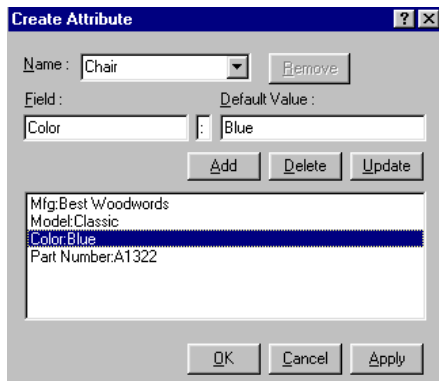

Each attribute can contain up to 128 lines of text. Each line consists of a field (sometimes referred to as a *label*), a punctuation separator (typically a colon), and a value. Each field and value can contain up to 79 characters. Enter text in each edit box, add the separator, and then click [Add ] to add it to the preview list below the edit boxes.

You can edit an attribute after you have attached or embedded it to a symbol.

---

**Tip** Delete an attribute field and default value when creating an attribute by selecting the field and then clicking [Delete].

---

### Displaying Attributes

Attributes are visible in your drawing when Display Attributes is checked on the Symbol dialog of the Utilities>Setting menu. Labels are visible when both Display Attributes and Display Fields are checked. The display of attributes is further affected by choosing either Global or

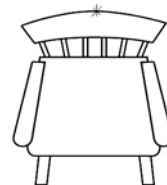

Mfg: Best Woodworks  
 Model: Classic  
 Color: Blue  
 Part Number: A1322

Local display. See the Help file for more information.

## Positioning Attributes

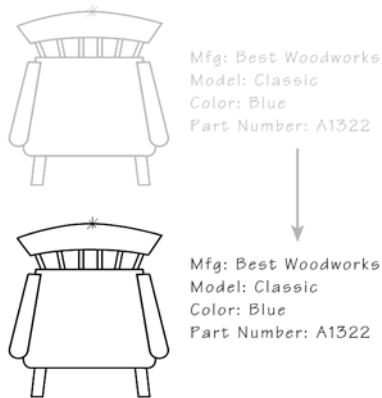

Once you have attached an attribute to a symbol, it maintains its position relative to the symbol, even when you move the symbol. You can however move the attribute separately, by selecting a symbol, right clicking and selecting Attribute Move, then clicking on the attribute to drag it to a new location.

## Changing the Properties of Attributes

When you change the font of attributes on the *Symbols* dialog on the Settings menu, the change applies to all attributes in your drawing. Changes made to other properties apply only to those attributes placed after you have made the changes.

## Creating an Attribute

---

### To create an attribute:

1. Select Symbol>Create Attribute (**TC** is the keyboard shortcut).
2. In the Create Attribute dialog, in the Name box, type a name for the attribute.
3. In the Field box, type a label for an attribute.
4. Type a colon or other separator in the box between Field and Default Value.
5. In the Default Value box, type text or numbers that you want to appear beside the label. For example, a field labeled Color might be followed by a colon (:) and the color Blue as the default value.
6. Click [Add] to add the item to the list of attributes.
7. Continue adding fields and default values to the attribute, and then click [OK].

### To save an attribute or attributes for use in other drawings:

1. Select Symbols>Save Attribute (**TS**).
2. In the Save Attribute dialog, select an attribute file or files, locate the folder in which you want to save it, and then click [OK].

### Load an attribute or attributes:

1. Select Symbols>Load Attribute (**TO**).
2. In the Load Attribute dialog select an attribute file or files (.VCA), and then click [OK] to load the file into memory. The attribute can now be attached to any symbol in any drawing open in Visual CADD.

### To attach an attribute to one occurrence of a symbol:

1. Select a symbol in your drawing.
2. Select Symbol>Attach Attributes (**TA**).
3. Select an attribute from the Attributes list. (If necessary, make changes in the Values text box, and then click [Update].)
4. Click [OK] and then place the attribute in your drawing next to or on the symbol.

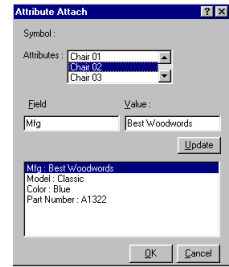

### To attach an attribute to a symbol definition:

1. In your drawing, select the symbol to which you want to attach the attribute.
2. Select Symbol>Embed Attribute (**TD**).
3. Select an attribute from the Attributes list. (If necessary, you can make changes in the Values text box, and then click [Update].)
4. Check Prompt Values if you want to be able to edit attribute values each time you place the symbol. Check Prompt Insert Point if you want to manually position the attribute each time you place the symbol. Click [OK].
5. Place the attribute in your drawing to set its default location, select Symbol>Save Symbol, enter a name for the symbol, and then select a folder to save it in.

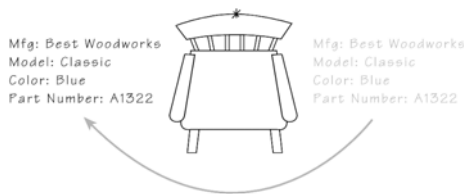

### To move an attribute after it is attached to a symbol:

1. Select the symbol with the attribute you want to move.
2. Right click and select Attribute Move.
3. Click the attribute you want to move, and then drag it to a new location.

### To edit an attribute after you have placed it:

1. Select the symbol with the attribute you want to edit.
2. Right click, and then select Attribute Edit.
3. In the Attribute Edit dialog, make any changes and click [OK].

## Rendering Objects with Hatch Patterns and Solid Fills

Use hatch patterns and fills to differentiate between solid and hollow objects and between different types of materials. They can help an object or objects stand out in a crowded drawing. When you hatch or fill an object, you create a new entity with the same shape as the selected object. Each hatch or fill entity has its own properties, such as color, layer and linewidth.

You can define new hatch settings and a fill color with the Hatch/Fill dialog on Utilities>Settings. Alternately, use the Hatch Settings command (**HT**) to set hatch options from a speedbar. Once placed, you can change basic properties of a fill or hatch pattern using Modify>Change. Edit other hatch settings as well as the basic properties with the Hatch Change command.

## Hatch and Fill Settings

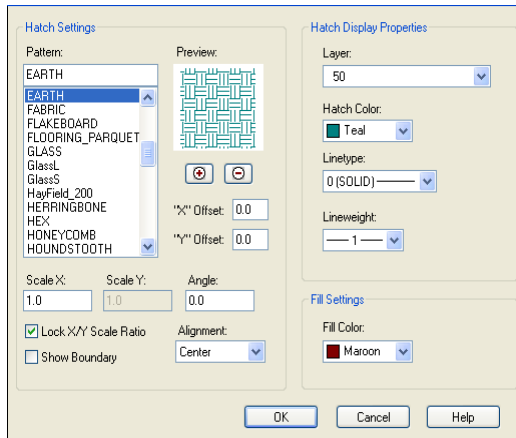

**Pattern** - lists the available hatch patterns. A Preview window shows the selected pattern. The buttons zoom in and out on the preview only and do not affect the hatch scale.

**Offsets** - offsets the hatch pattern in the X or Y direction when you type in a positive or negative value.

**Scale** - sets the scale of the selected hatch pattern (1.0=100%). X and Y scales can be set differently, and also locked so that both are the same ratio.

**Boundary** - displays fill and hatch boundaries as lines on the screen.

**Angle** - sets the selected hatch angle.

Type a positive or negative value between 0 and 360.

**Alignment** - offers four options to set (or edit) the starting point of a hatch pattern: Center, Origin, Lower Left corner and First Point. Use these option to align hatch patterns of the same type that are placed adjacent to each other.

**Hatch Display Properties** - set any or all settings for layer, color, linetype and lineweight to a specific setting so that they apply to all hatches drawn. You also have the option to set any property to <current> so that it takes on the setting that is current in the drawing when the hatch is placed. See the Help file for complete details.

**Fill Settings** - sets the fill color for the next fill drawn. If you select <current> the fill will be drawn with the color current in the drawing when the fill is placed.

### To hatch a closed object with the current hatch:

1. Select an object or objects.
2. Click the Hatch Selection tool.

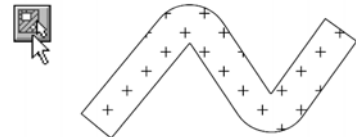

### To fill a closed object with a solid color:

1. Select an object or objects.
2. Click the Fill Selection tool.



### To draw an irregular polygon and add a hatch pattern or solid fill:

3. Click the Hatch Boundary tool or the Fill Boundary tool.
4. Place points defining the vertices of the closed polygon.
5. To finish, right-click, and select Pen Up (PU) from the local menu.

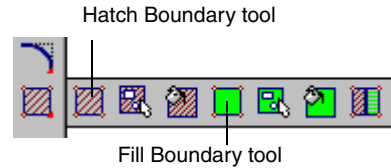

**Tip** To use the Selection and Seed tools for hatches and fills, the objects you select **MUST** have a closed boundary. Otherwise you will get an error message and the hatch will not be applied. Use the Trim and Extend tools to create a closed boundary before hatching.

## Changing the Hatch Pattern of a Hatched Entity

Materials and finishes sometimes change in the life of a project. To change the rendered material in your drawing, you change the hatch pattern and perhaps some of the properties associated with it. In Visual CADD you can change a hatch pattern after it is applied to an object. Use the Hatch Change dialog to change the pattern, angle, scale, alignment, offset, and basic properties such as layer, color or linewidth. You can change one or several properties of more than one hatched object, even if the objects contain different hatch patterns.

### Hatch Change Dialog

Select a hatch and start the command from the Draw menu or type **HC** (or **ED**). The same settings described earlier for the Hatch/Fill Settings dialog apply to the Hatch Change dialog. If you drag the dialog to the side of the screen so that the hatch is visible, you can see the result of your changes by clicking the Apply button. When you are satisfied, click [OK] to finish.

You can enter offset values to incrementally “bump” adjacent hatches of the same pattern along the X and Y axis so that they align with each other.

### To change the hatch pattern of a hatched entity:

1. Select one or more hatched objects.
2. Select Draw>Hatch>Hatch Change.
3. Make changes to the hatch settings, and then click [Apply]. Click OK when you are done with the changes.

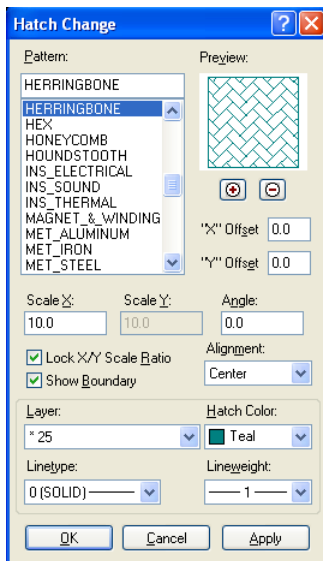

## PRACTICAL & ADVANCED TECHNIQUES

In conventional drafting you use a variety of techniques to draw quickly and efficiently. Beyond the basic drafting commands such as lines and rectangles, Visual CADD offers many advanced tools to speed up your work.

You can match some or all properties of an object already in the drawing and apply them to the next object you draw. You can quickly change an existing object to match another in the drawing. Other tools allow you to quickly set distances and angles.

A new v6 feature is the ability to add graphic images such as JPG or GIF into your drawings.

By using Reference Frame entities, you can combine information from one or more drawings into another drawing, at varying scales. You can control the scale and the layer visibility of each reference frame entity that you insert into another drawing. For example, you can create a larger detail within a main drawing that might contain a floor plan or building section at a smaller scale.

Use a Digitizer to create drawings in Visual CADD based on existing hand drafted ones, by tracing the geometry of the paper drawing to create a CADD file. You can also use a digitizer as a Windows pointing device instead of a mouse.

### Setting Properties and Drawing Tools by Example

---

When you want to draw an object with the same properties as an existing object in the drawing, you can use the existing object as an example. You can also match the properties *and* start a drawing tool in one step.

This is an easy way to set properties for all subsequent objects you draw. For example, if you select a line, use the *Match Entity* tool to set the current layer and line color, type, and width. If you select a dimension, use the Match Entity tool to make all dimension settings match a dimension already in the drawing, including arrow types and styles, offsets, text size, aspect, and spacing.

You can use the Match button on the Change and Ortho Angle speedbars to change all or selected properties for existing entities and to set an angle for the next object you draw.

**Note:** If you match the color, linetype, or linewidth of an object whose properties are set to **LP** (layer properties, see chapter 4), the properties may appear to be different than those of the object you match, depending on the layer properties of the new layer.

## Matching Properties and Tools

*Match Tool* sets the properties and then starts the tool of the next entity you draw based on an object you select in the drawing.

The *Match Entity* tool sets the properties of the next entity you draw based on an entity you select.

The Match Entity tool on a speedbar sets the selected property of the entity you are drawing based on an entity you select.

When you click the Match tool or Match Entity tool, the cursor appears with an equal sign (=) until you click on the entity you want to match.

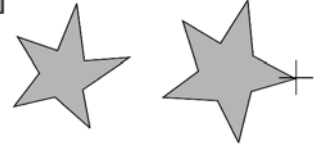

### To...

### Do this...

Set all properties of the entities you are about to draw to match another entity's properties:

Click a drawing tool, click the Utilities menu, click Match Entity, and then click an entity whose properties you want to match.

Change a single property of an existing entity or entities to match another entity's property:

Select an object in the drawing, then select Modify>Change, click the Match Entity button on the speedbar, and then click in the property box you want to change on the speedbar. Now click an entity in the drawing whose property you want to match.

Use the angle of a line as an example for the line you are drawing:

While drawing, select Snaps>Ortho Angle, click the Match Entity tool on the ortho angle speedbar, click the object whose angle you want to match, click [OK] to close the speedbar, and then continue drawing.

**Tip** A quick way to change all properties of an existing entity to match those of another is to select an object(s), type **CG** then = sign, and click the entity that you want to match.

# Setting Distances and Angles Quickly

---

When you want to use an example to enter or change a setting for a length, height, or angle in a speedbar, but the object with the desired length, height, or angle doesn't exist in your drawing, you can use distance, angle, and vertex input options. You can only use distance, angle, and vertex input options within other commands, settings, and any distance or angle text boxes.

## To enter a distance by creating an example:

On a speedbar, click the distance, height, or length text box, type **D**, and then place two points in your drawing that establish the distance you want. When you type **D**, it is not shown in the box, but the Status Bar prompts you to enter a start point and then an end point.

For example, to specify an offset distance by creating an example, select an object in the drawing and then select **Modify>Offset**. Then in the speed bar, type **D** for the offset distance. The **D** does not appear, but the Status Bar prompts you to enter a start and end point. You then set two points to define the distance.

## To enter an angle by creating an example:

On a speedbar, click the rotation angle box, type **A**, then place two points in your drawing to show the angle.

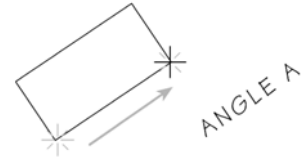

## To enter a vertex angle by creating an example:

On the Radial Copy speedbar, click the *Span Angle* box, type **V**, then place three points in your drawing to show the vertex angle you want.

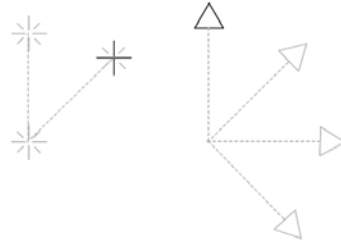

---

**Note** When you enter a **D**, **A**, or **V** in a speedbar edit box, the letter is not shown. After you type the letter, the Status Bar prompts you to specify points.

---

# Inserting an Image

---

With the new *Image* command in version 6 you can import raster image files such as JPG or GIF directly into the program. An imported Image is a Visual CADD object and as such you can use any command to modify it. Select an existing image in a drawing and you can move, copy, rotate and scale it. You can assign it to any layer. If it has a border you can set the color, linetype and lineweight for the border.

## To use the Image command:

1. Start the command from the Draw menu, or by typing **IG** from the keyboard.
2. From the dialog, select the Image file you want to open. If necessary, change the path and drive in order to locate the file. Use the arrow keys or the mouse to scroll through the list and view the images in the Preview window.
3. If you want to change properties of the image before placement, click the Settings button to open a dialog. See below for details on Settings.
4. In the list box, double-click the file name, or select the file name and click Open.
5. The status bar prompts you to place the upper left corner of the image location. Left click the mouse to set the point.
6. Drag the mouse to the right and down to view a bounding rectangle. You are prompted to place the lower right corner point to complete the Image placement. A mouse click sets the size of the Image.

## Image Settings:

---

When placing an Image from the Draw menu you can click the Settings button to make changes before placement. If you do an Environment Save (EN) after making these changes they are saved for all subsequent new placements.

When you select an existing Image in the drawing and then type ED (or right click and select Image Edit from the popup), any editing changes only affect that image. They do not change the prior settings you chose for placement of any further new images.

---

**Tip** When you want to edit or modify an existing image, click near the border to select it rather than in the middle.

---

**Embed Image** - saves the image with the drawing file. Note that this increases the file size.

**Image Path** - for an image that is not embedded, Visual CADD must know where to find the image file. The path to the image can either be an absolute one that completely specifies the file location - e.g. "C:\Images\MyImage.jpg" - or it can be relative to the drawing file location - ".\MyImage.jpg". An absolute path is useful

when one image is used in many drawings. A relative path is useful when a drawing may be shared between computers that have different folder names.

**Lock Aspect Ratio** - only applies to placement of a new image in Visual CADD, to allow for odd sizing. To resize the image after it is placed, use the *Scale* command.

When the checkbox is ticked the X/Y ratio is locked so that the drawing will appear with the original aspect. Unticked, you can drag the bounding box on placement to control different X and Y ratios.

**Rotation** - only applies to placement of a new image in Visual CADD. The *Rotate* command in VCADD can be used to modify the image, but it is not available when first placing the image.

**Flip horizontal** - flips the image 180 degrees.

**Flip Vertical** - flips the image 90 degrees.

**Show Image as Greyscale** - displays the image with no color.

**Display Border** - shows a border around the image using color, linetype and linewidth that are current in the drawing. You can change these properties by selecting the image and making changes in the property dropdowns on the mainsbar.

**Display Image** - unticking the checkbox will cause the image to not display in the drawing. If you have a border set to display the border will still be visible.

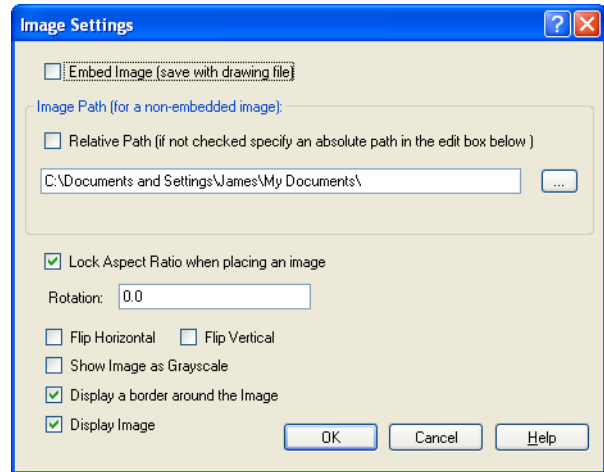

## Bearings

---

Visual CADD versions 4 and 5 offered the *Bearing Tools*. They included an alternate to the normal method of entering polar coordinates, a tool to quickly add uncommon dimension labels to lines, and a settings dialog that offered angular format options not found elsewhere in Visual CADD: surveyor, radians and grads for example.

That dialog also provided an option to change the default base angle and direction of angles entered. Visual CADD uses a default base angle of 3 o'clock and then draws positive angles in a counterclockwise direction. This default does not always reflect real world conditions --for instance a surveyor might want to use 12 o'clock as a base angle with positive angles drawn in a clockwise direction. *Bearing Settings* gave you the option to make this change.

But the Bearing tools had limitations, especially with the base angle. Although you could *set* the angle to 12 o'clock and clockwise and then use *Bearing/Distance* to draw a line from left to right (which should be 90° from 12 o'clock), Visual CADD would still report it as 0° because internally the base angle was still read as 3 o'clock.

In addition, the *Bearing Labels* were *overwritten* dimension strings, meaning that they were no longer associative. If you stretched a line, the dimension string would not change to properly reflect the new length.

Visual CADD 6 has removed the bearing tools and incorporated all the Bearings features and improved them to fix the problems described above. An overview:

1. Enhanced polar coordinate entry now recognizes polar input without needing to use a comma before the less-than symbol required in earlier versions. For surveyor input you can now eliminate the less-than symbol and use only a comma if desired. Inputs of “1,<45”, “1<45”, “1,<N45W”, “1,N45W” and “1<N45W” all now work for polar input. Using the comma both replicates and improves the input behavior of the old *Bearing/Distance* tool for surveyor input.
2. On the Angular Format dropdown of the Numeric dialog you now have several new choices including Radians, Grads and Surveyor. Coupled with the ability to set the base angle as described below and the polar input methods mentioned above, it opens up new options for quickly creating site and plot plans and other types of drawings.
3. The new Base Angle setting on the Numeric dialog is saved with each drawing. The default setting of 0 degrees at 3 o'clock can be changed to any angle, and the coordinates in the status bar will reflect this. Replaces and enhances the old *Bearing Settings* dialog.
4. The Multiple Dimension (MM) command has been added to the Draw menu to quickly add linear dimensions to selected objects. Replaces the old *Bearing Labels* command.

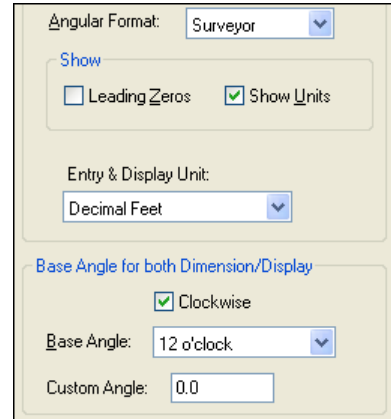

To give you an idea how all this works in v6, the following example uses Surveyor settings to draw a simple rectangle that might represent a site plan for a building lot. Check first to see that you are using Relative entry (**MR**), Ortho Mode Off (toggle **OR**), Grid Snap Off (toggle **SG**). Any of these can have a negative effect on your intended input.

### To draw the building lot:

1. On the Numeric Settings dialog, choose “Surveyor” from the *Angular Format* box on both the Numeric Dimension and Numeric Display sides of the dialog. Set both

*Decimal Places* at two (0.12) . For the *Unit* choose Decimal Feet for both. In *Base Angle*, set it at 12 o'clock and tick the Clockwise box.

2. Start the Continuous Line tool (**LC**) and place the first point of the property line.
3. To place the second point, type **100,n45e** with a comma separating the distance and bearing, and press ENTER.
4. Type **100,s45e** and press ENTER.
5. Type **100,s45w** and press ENTER.
6. Type **100,n45w** and press ENTER.
7. Select Pen Up from the right mouse menu or type **PU** to finish.

#### To dimension the lot lines:

1. On the Dimension Settings dialog, in the Display Properties section untick the line and arrow and extension checkboxes so that only Text is displayed when placing a dimension.
2. On the Dimension Text dialog, set Font and Height and other settings as desired. In the lower right of the dialog, set the *Distance/Angle Display*. The default setting shows only the distance, but you can change it to display “Angle then Distance” or “Distance then Angle”. Using the latter setting in our example the first line will be labeled **100.00' N45d00'00"E** in the drawing.
3. Select the four lines and start the Multiple Dimension command from the Draw Menu or by typing **MM**.
4. Drag and place the dimensions for each line. The labels will be placed in the order that the lines were drawn. See the Help file or Chapter 9 of this guide for step by step instructions on running the Multiple Dimension tool.

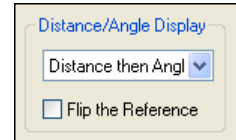

---

**Tip** Use the Save Style command in Visual CADD to set up and implement settings to draw plot plans or other drawings with specific Numeric settings. Note that Visual CADD 6 includes a sample style named PropertyLines.vcsty that has some settings described in the example above.

---

**Note** The old Bearing Tools are still available as part of our v6 Toolkit at the TriTools website.

---

## Adding Reference Frame Entities to Your Drawing

---

Adding a reference frame to a drawing lets you display a selected part of a drawing within the frame. It is a great way to organize details of different scales in one drawing, or to set up layouts for printing. You can insert multiple reference frames into the current drawing, and these frames can be used to reference either several different files or different views of one file.

Previous versions of Visual CADD only allowed you to insert the content of a separate file into a reference frame in the current drawing. In Visual CADD 6 you can create reference frames that contain objects from the same file.

A reference frame is a Visual CADD object, same as a line, polygon or leader. When inserted it is placed on the current layer, but this can be changed later. If you choose to display a boundary around the frame, it can be modified with a different color, linetype and linewidth.

When you add a reference frame, you can either define the size of the frame and the referenced drawing will fit into it, or you can specify the location of the frame and it will be sized to display the entire referenced drawing at full scale.

You can choose either *Bind Data* to insert the contents of the referenced drawing into the current drawing, or *Link File* to link the content. If you link to the referenced drawing, any changes made to it will be updated in the reference frame. Linking will also greatly reduce the size of the drawing containing the reference frame, because bound data is added to the current drawing file.

Reference frames are also sometimes used when converting an AutoCAD file to Visual CADD. If the DWG has Layout Spaces and/or XREFs, they will appear as reference frames in the converted drawing.

Reference frames can be displayed as opaque, or as transparent, so that grids or other Visual CADD objects such as lines or circles under the frame in the current drawing will also display with the latter option.

## Using Reference Frames to Display Information

---

### Placing A Reference Frame

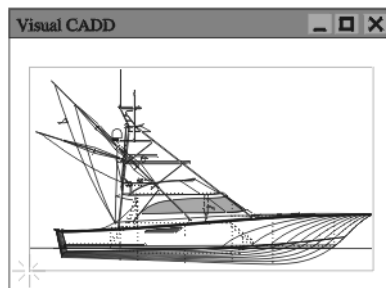

Click once in the current drawing to locate a frame that is sized to fit the entire drawing.

### Creating a Reference Frame

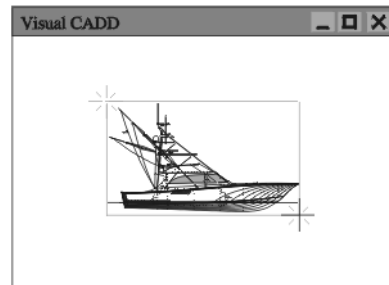

Click both corners to size the drawing to the frame.

### To create a reference frame in which to fit a drawing:

1. Select Draw>Reference Frame>Create.

2. Click two points representing the corners of the reference frame.
3. Click [Browse] to find a drawing file on a drive, *or*
4. Click to check the box *Insert a File already Open in Visual CADD* and select a file from the dropdown list.
5. Click [OK] to insert the file.

**To place a reference frame that displays an entire drawing at full scale:**

1. Select Draw>Reference Frame>Place.
2. Click [Browse] to find a drawing file on disk, *or*
3. Click to check the box *Insert a File already Open in Visual CADD* and select a file from the dropdown list.
4. Click the point in the drawing where you want to place the lower left corner of the frame.

---

**Tips** To add objects from the same drawing into a Reference Frame, use the *Insert a File already Open in Visual CADD* option then click on the name of the current file.

A new feature in Visual CADD 6 is the Elliptical Boundary option to set the boundary of the reference frame containing objects to an ellipse shape. You can set this before adding the Reference Frame or edit to change the shape after placement of the RF.

---

## Adjusting a Reference Frame Entity

---

Once you have added a reference frame entity to your drawing, you control its contents.

You can zoom in or out by using the reference frame zoom commands. Or use a Bird's-eye view to display the whole drawing to which the reference frame is connected.

If you don't want to see all of the drawing information within a reference frame, you can hide layers without affecting the original drawing.

You can also change an existing reference frame to display a different drawing. This is useful if a drawing name changes during revisions.

---

**Tip** See Reference Frame entity commands and options by selecting an existing Frame and right clicking to display the RF popup menu.

To create accurate details within a drawing without copying or recreating entities, set a Reference Frame to display its contents at an exact scale by using the RF Zoom Scale command.

---

# Controlling What is Visible in a Reference Frame

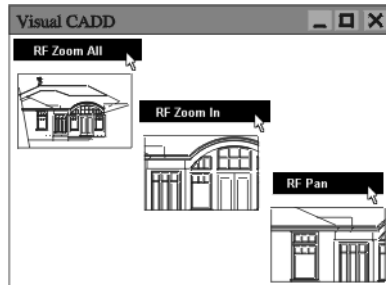

Use RF zoom commands to control the scale at which reference frames are displayed

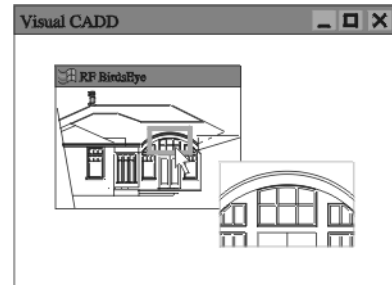

Use the RF Bird's-eye view to quickly zoom to a different part of the reference frame.

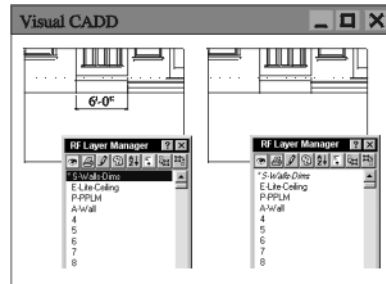

Use RF *Layer Manager* to display and hide layers of information within a reference frame.

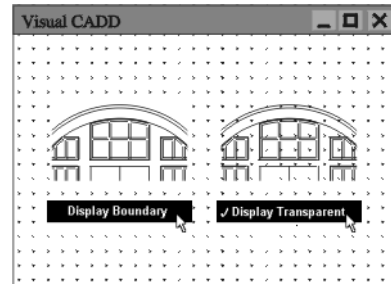

Uncheck Display Boundary on the right mouse menu to hide the reference frame border. Check Display Transparent so that entities and grid marks in the current drawing show through a reference frame.

## To resize a reference frame:

1. Select a reference frame.
2. Right click and select *RF Resize* from the popup menu.
3. Drag the rubberband line up and to the right to expand the frame size, down and to the left to reduce it.
4. Click to set the upper right corner and the new size of the reference frame.

## To change the zoom scale or view of a reference frame:

1. Select a reference frame.
2. Right click, and select one of the *RF Zoom* commands or the *RF Bird's-Eye View* command from the popup menu.
3. Reposition the contents of the reference frame as you would with any Visual CADD zoom command.

**To adjust layer visibility in a reference frame:**

1. Select a reference frame.
2. Right click and select *RF Layer Manager*.
3. Use the icons to display or hide selected layers within the reference frame.

**To change the file that a reference frame displays:**

1. Select a reference frame.
2. Right click and select *Change Reference*.
3. Select the new file that you want the reference frame to display.

**To change display properties of a reference frame:**

1. Select a reference frame.
2. Right click and then click on *Display Boundary*, *Display Transparent* or *Use Elliptical Boundary*. This will change the state of that particular item.

## Using a Digitizer

---

With a digitizer, you can create drawings in Visual CADD based on pre-existing hand drafted ones. You create the drawing by attaching the paper copy to your digitizer and tracing its geometry. For Visual CADD to read the input from your digitizer, you must first align your drawing.

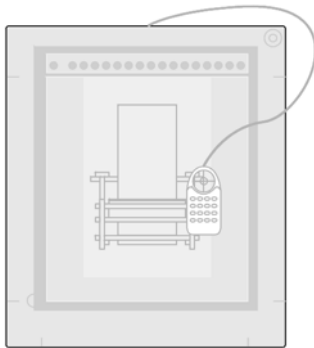

Your digitizer can be used as a normal Windows pointing device when Visual CADD is in mouse mode. When in tablet mode, however, you cannot point to screen menus or buttons with the puck. Instead, you must use digitizer buttons, function keys, keyboard commands, and scripts. Tablet mode only affects the digitizer's functioning in Visual CADD, not in other applications.

In addition to activating tablet mode, you must specify the relationships between the paper and the electronic drawings when using a digitizer.

You can adjust the digitizer scale by overriding the scale calculated by the Align Drawing command with a value of your own. For example, the Align Drawing command might calculate a scale of 47.65:1. If you know that the actual scale is 48:1 ( $1/4'' = 1' - 0''$ ), you can override the calculated value.

---

**Note** You must have a Wintab-compliant digitizer with a Wintab32 driver to use Visual CADD's tablet mode functions. Your digitizer manufacturer can supply the appropriate driver.

---

## Digitizing a Drawing

Use a digitizer to precisely transfer a paper drawing to editable electronic form.

### To digitize points from a paper drawing:

1. Select Utilities>Digitizer>Tablet Mode (or type **GM**).
2. After using the Align Drawing or Digitizer Scale command, click points on the digitizer to draw scaled entities in Visual CADD.

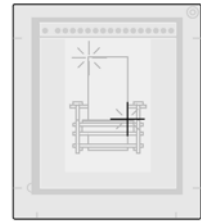

### To align a drawing for digitizing:

1. Securely attach your paper drawing to the digitizer.
2. Select Utilities>Digitizer>Align Drawing (or type **GA**).
3. Draw a line that represents a line on the paper whose length and angle you know.
4. Align the digitizer crosshairs at each end of the line on the paper and click at the end-points, noting the dimensioned length of the line.
5. In Visual CADD, move the cursor to one end of the line, type **NP** (Near Point Snap), move the cursor to the opposite end of the line, and then type **NP** again.
6. Confirm the displayed scale value or type a new value on the trace scale speedbar.



or

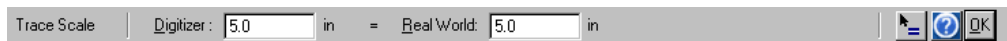
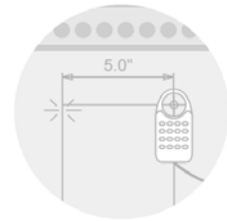
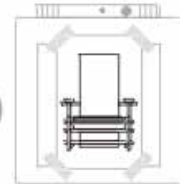

### To adjust the digitizing scale:

1. Select Utilities>Digitizer>Dig Scale (or type **GZ**).
2. Enter a reference distance as measured on the surface of the paper.
3. Enter the real-world distance represented by the previous measurement.

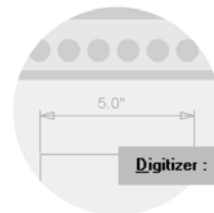

Digitizer : 5.0 In

Real World: 5.0 In

# Running Visual CADD at Top Speed

---

**Turn off unnecessary display elements.** Construction points, line types and widths, handle points, fills, hatches, and fonts containing fills are all elements that must be redrawn. You can hide these elements on the *System1* section of the Settings dialog (many of them also have keyboard shortcuts for toggling on and off). Turning off the display of attributes on the Symbol dialog on Settings can also speed redraw time.

**Work at a close in view, and change views using Bird's-Eye view.** Because Visual CADD searches through only the entities on the screen when you snap to a point or an object, the greater the magnification of your view, the faster Visual CADD will snap to a point. Draw a selection frame in the Bird's-Eye View window to select the view and level of magnification in one step.

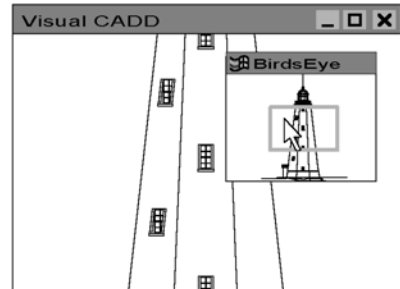

**Hide layers containing objects you don't need to see.** Only display the layers on which you need to work so that Visual CADD doesn't redraw unused objects.

**Stop redraw after Visual CADD redraws what you want to see.** Shorten the time it takes to zoom in on the most recently drawn entities in your drawing by selecting *Zooms>Backward Redraw*. When you next choose a zoom command, wait until what you want appears on the screen, and then press ESC to stop the redraw.

**Use the Pack Data command periodically to delete all record of objects that have changed, freeing memory and restoring optimal system performance.** When you modify objects with commands such as Move and Erase, the objects are not deleted from the database; they simply don't display in the drawing. They remain in the database so that the Undo and Redo commands can be used to bring these objects back into the drawing display if desired. As the database grows in size it can affect the performance of Visual CADD and of your computer. Pack Data compacts the database by deleting these objects.

---

**Note** Newer computer systems have enough horsepower so that many of these suggestions may not be necessary. Try them if you have performance problems. No matter the computer power though, we recommend running the Pack Data command often to keep file size small and avoid possible data corruption.

---



## CUSTOMIZING VISUAL CADD

CADD software “out of the box” may not conform to your unique drawing style and needs. In Visual CADD, you can customize most of the drawing interface, including menus, buttons, toolbars, and keyboard shortcuts. You can create new linetypes and hatch patterns. And you can create scripts and custom commands that run a series of actions with a couple of keystrokes.

Some customizing is done in standard Visual CADD dialogs. In some cases you will need to edit files, but version 6 gives you new tools to do this from within the interface. v6 also introduces the new XML file format as described in this chapter.

### Automating Actions with Scripts

---

If you repeat actions often when drawing in Visual CADD, you can write a script and assign it to a single key or a combination of keystrokes. The next time you want to repeat those actions, press the key combination you have assigned to it.

Using the Assign Script command, you can assign a script to function keys, key combinations, and mouse and digitizer buttons. The Assign Script dialog lists all Visual CADD native commands. To write a script, enter either the native command name or the equivalent keyboard shortcut. If you will trade scripts with others, use the full command name. Keyboard shortcuts can be customized and might have a different meaning on another person's system, so the script may not run correctly.

Some of the elements you need to add to scripts are not listed with the native commands on the Assign Script dialog. These you type directly in the Edit Script text box; see the tables on the following page. Be sure to write a script that incorporates all steps to complete an operation. For example, many native commands require a parameter --a number or text string-- to change a setting in Visual CADD (the native *MultiLineStyle* shows one example in the table). The Help file has much more detailed information and examples about scripts, including script parameters.

You can initiate a script when Visual CADD starts by adding a script to the Startup section at the bottom of the Assign Script dialog, or via a Windows shortcut dialog for Visual CADD. You might use this to start Visual CADD with a specific menu or drawing file, or to load a completely different System folder with customized settings.

## Script Examples

| This script...                               | Results in this action...   |
|--|---|
| CS;SX;@;@;CO;                                | Copies objects you first select using a crossing window.  |
| MulLineStyle;1;MultiLine;                    | Sets the Style to 1 and starts the MultiLine command.   |
| SYMROT;\$SYMROT+15;                          | Sets Symbol angle to 15° more than current angle.   |
| CS;SB;@;LE;NP;                               | Prompts to select a leader and flips the text of the Leader.  |
| TextRot;=;TL;@;                              | Sets text angle to the angle of an object you pick in the drawing and then starts the Text Line command.              |
| SetLayer;3;SetColor;12;SetType;6;SetWidth;1; | Sets the properties for layer, color, linetype and linewidth. The next object you draw will take on these properties. |

## Common Script Elements

| This element...  | Does this...  |
|--|---|
| ;  | Separates the commands in a script. Scripts must end with a semi-colon (;) as well.                           |
| @  | Tells Visual CADD to wait for you to type the coordinates of a point or for a click on the drawing screen.    |
| @ @  | Tells Visual CADD to wait for a Pen Up command to finish a continuous tool before moving to the next command. |
| \$   | Retrieves the current value of the variable it precedes.  |
| =;@  | Matches the entity you select.  |
| Uloff  | Closes the specified speed bar.   |
| Ulon   | Opens the specified speed bar.  |
| exename;<br><path to external applica-<br>tion>;run;                           | Tells Visual CADD to run an external application from within Visual CADD.                                     |
| dllname;<dll filename>;<br>dllfunname;<functionname within<br>the dll>;dllrun; | Runs a function defined in a .dll file.   |
| <b>NOTE:</b> Scripts never contain quotation marks (").                        |   |

### To assign a script:

1. Select Utilities>Assign Script and make sure the *Assign Script* tab is current.
2. In the *Assign Script to a Key* dropdown, click the down arrow and choose a mouse button or key to assign the script. Key options include FUNCTION keys, SHIFT+FUNCTION or CTRL+FUNCTION keys, and CTRL+NUMBER or CTRL+LETTER keys.

- Highlight a native command from the Command List and click the double arrowed button to add it to the Edit Script box to the left; or type it directly in the box (you can also double click a command to add it to the box).

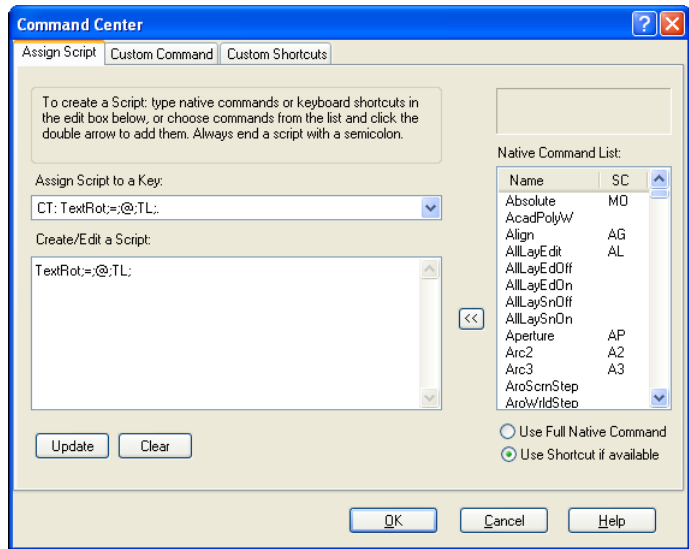

- Repeat the step above to add additional commands to the script. By default each command added from the right side list will include and end with a semicolon.
- To introduce other elements as described in the table, you will need to manually add them. For example, the script shown in the graphic above has an equal sign and an @ sign that must be manually added, with a semicolon after. All scripts must end with a semicolon.
- Press [Update] to save your work and then either create or edit additional scripts, or press [OK] to exit the dialog.

### To create a script that will run when you start Visual CADD:

- Start the Assign Script command from the menu or toolbar (or type AS).
- Click the arrow at the right of the Assign to Key dropdown box.
- Scroll to the end of the list and select the item labeled Startup. If the Startup entry has already been assigned a script and you want to use a different one, select to highlight the script in the edit box and then press the [Clear] button.
- Type the command sequence you want to program into the Edit Script box, or select a command from the Native Command List to the right and click the [<<] button to add it to the script.
- When you are satisfied with the script, click [Update] to save the startup script.
- Click [OK] to close the Assign Script dialog box.
- The next time you start Visual CADD the script will be applied.

For more information and some example scripts, see the *Startup Scripts* topic in the Visual CADD 6 Help file.

# Custom Commands

As described above, a script can be assigned to a mouse button, function key or a combo of Windows shortcut keys. By wrapping a script in a Custom Command, you can also assign the script to a Visual CADD menu, a toolbar, or a 2 or 3 letter shortcut of your choosing. You can designate a bitmap if you decide to add the command name to a toolbar.

Custom Commands are also used by developers writing add-on tools. One example is shown at right.

This is the OrthoMatch command from our TriTools toolkit (available for free at our website for all v6 customers).

As you can see, it includes the command name, keyboard shortcut, menu and status bar descriptions, and the script that runs the command.

The script here is very different from the earlier example. It references external filenames and functions. When dealing with these external commands, it is important that you do not change the command name or the script as it will cause the command to no longer function. You can safely change the shortcut and the text descriptions, as well as the optional bitmap if included (there isn't one for the OrthoMatch command).

When creating your own Custom Commands however you have complete control over all elements. In the example below we use the same script described earlier. That script sets a new text rotation angle with this sequence: press CTRL+T to start the script, then you are prompted to click on an object in the drawing to match its angle, and finally the Text Line command starts at the ortho angle of the matched object.

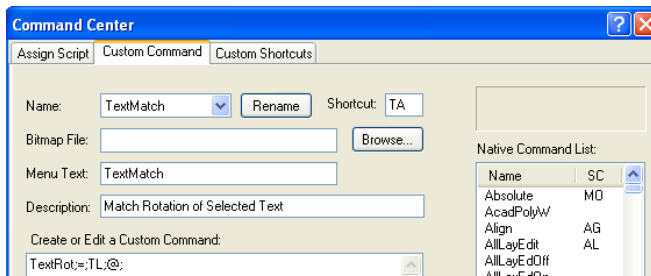
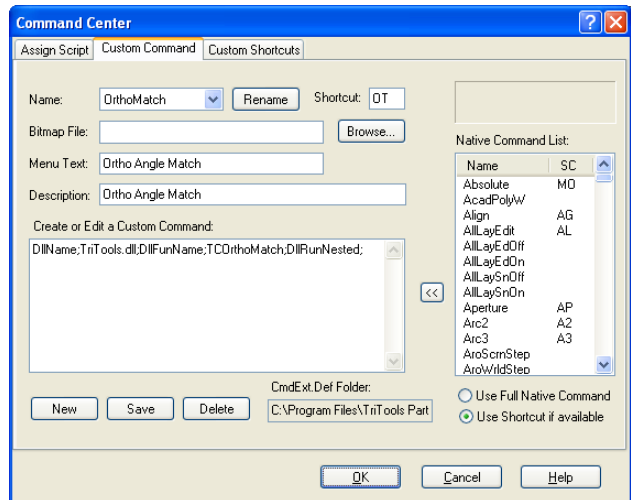

To create a command to run this script, click the New button and type in a name that is between four and twelve characters long. Add a 2 or 3 letter shortcut if desired. Be careful not to duplicate any shortcuts that already exist.

Add a bitmap file and menu description if desired. The former will display on a toolbar and the latter will appear on a menu if you add the custom command name to a toolbar or menu file. If you add a description the text appears on the Status Bar when you run the Custom Command.

Add the script as described in the earlier section, then save the new command and click [OK] to exit the dialog.

See the *Customizing* section of VCADD 6 Help for detailed info on Custom Commands.

---

**Note** Custom Commands take precedence over internal native commands. If you create a custom command with the same name or keyboard shortcut as a native command, the latter will not work and the custom command will run instead. Be careful not to duplicate existing shortcuts or native command names.

---

## Customizing Keyboard Shortcuts

---

One of the more powerful time saving features in Visual CADD are the keyboard shortcuts. You can quickly start commands from the keyboard rather than mousing up into menus or toolbars.

You can also modify these shortcuts. The Custom Shortcuts tab option available with the Assign Script command is a new feature in version 6. It allows you to change the 2 and 3 letter keyboard shortcuts for the native commands in Visual CADD directly from within the interface. In previous versions this had to be done in an external file.

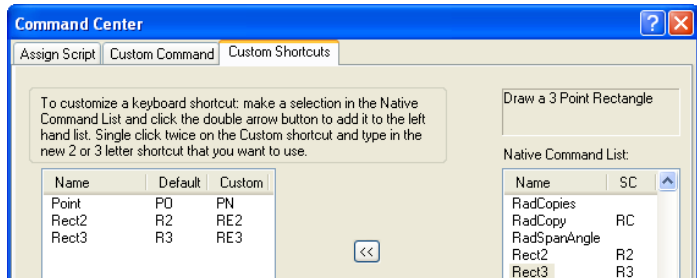

### To customize a keyboard shortcut:

1. Start the Assign Script command from the menu or toolbar (or type **AS**).
2. Click the Custom Shortcuts tab if it is not already open.
3. Scroll the Native Command list until you find the native command that you want to add or modify a shortcut and select it.
4. Click the double arrow button to add it to the left hand list. Double clicking on the native will also add it to this list.
5. Left click anywhere on the new item, in the Name, Default or Custom columns to select and highlight it.

6. Click again in any of the columns of the selection and a bounding text box will appear in the Custom column, with the custom shortcut highlighted.
7. Change the shortcut, and click [Update] if you want to continue changing other native shortcuts, or [OK] if you want to keep the change and end the command.

---

**Tip** Many native commands change individual settings in Visual CADD instead of starting a tool. The native *DimTextSlant* is an example. This command works only as part of a script --for example "...DimTextSlant;10;..." sets the slant to 10 degrees. Assigning a keyboard shortcut to this command doesn't work, because there is no dialog or other way to specify the angle "on the fly"; it must be hardcoded in a script.

---

## The Configuration Editor

---

Customizing of menus, toolbars, hatches and linetypes are done in external files. All v6 customizable files are now in the XML format rather than the old ASCII text.

XML is a text based document format that uses *elements* to group information. Because of its flexible, hierarchical structure it is ideally suited to VCADD's configuration files. The new Configuration Editor in v6 is an XML editor that has been customized to work with VCADD files. Note that you can use any XML editor or text editor with XML files. The two main advantages of the VCADD editor is that it knows where to find VCADD 6 configuration files and that it will convert older customization files to the new format.

### To Open the Configuration Editor:

1. From the Utilities menu, select Configuration Editor.
2. From the File menu of the editor, you can choose to create a new XML file, open any XML file, or open a specific Visual CADD file. Select the latter and you will see a flyout with options for the System Folder, where most of the customizable files are located, as well as specific file types such as Menus, Styles, Toolbars, Hatches etc.
3. If needed, change the File of Type in the dropdown. By default the new v6 XML format will be displayed (it adds a *vc* to the front of the older file extensions, for example *mnu* is now *vcmnu*). You can change the type to choose to open an older file and convert it to the new XML format for use in v6.
4. If needed, change the path to the file. Select the filename you want to open.
5. Click [Open] or press [Enter] to complete the command.

---

**Tip** For detailed information and options on converting your older files to the new v6 XML format in the Config Editor, see the Tips section of the Configuration Editor topic in the v6 Help file.

---

# Creating Custom Menus

---

Menus can be altered by adding, deleting or rearranging either Native or Custom commands. New menus can be created either from scratch or by using an existing file as a starting point.

In Visual CADD 6 custom menus are saved as XML files with the .VCMNU extension. This is a big change from v5 and earlier versions where the file was in ASCII text format with an extension of .mnu. You open and edit XML menu files in the new Configuration Editor.

Place any new custom menu files in the *Menus* folder, which is on the same level as the *System* folder and by default is installed to a Visual CADD 6 folder in *My Documents*. When you right click on the top menu bar in Visual CADD these menus will display in the list. Left click on a menu to make it current. Run the Save Current Environment command (EN) to use it as the default in the next drawing session.

What follows is an example of the new XML format showing the first several commands in the *Custom.vcmnu* file located in the *Menus* folder. Also included is the very last command of the menu (in the Help section), and the tags that complete the XML file. These tags are typically referred to as *elements* and add a structure to identify each line of the file:

```
<MenuFile>
<Menu>
<Popup Label=" &File">
<Item Label=" &New\^aCtrl+N" Command="FileNew"/>
<Item Label=" &Open...\^aCtrl+O" Command="FileOpen"/>
<Item Label=" &Close" Command="FileClose"/>
<Separator/>
<Item Label=" &Merge..." Command="FileMerge"/>
<Separator/>
<Item Label=" &Save\^aCtrl+S" Command="FileSave"/>
<Item Label="Save &As..." Command="FileSaveAs"/>
<Item Label="Save All" Command="FileSaveAll"/>
<Separator/>
<Popup Label=" &Import">
<Item Label=" &CADD Files" Command="ImportCAD"/>
<Item Label=" &XML File" Command="ImportXML"/>
</Popup>
....
....
....
<Item Label=" &About Visual CADD 6.0" Command="HelpAbout"/>
</Popup>
</Menu>
</MenuFile>
```

**Popup Label** - signifies the start of a discrete menu section (File, Edit, Modify) and also any flyout menu item within the section (with File for example it is used for the Import flyout, which has two commands, and the Export flyout which has four).

**Item Label** - the first item is the menu description that appears on a menu. Most will be preceded by *&amp;*, which is a code that signifies the command can be opened from the keyboard. For example, "&File" means that if you hold down the ALT key and press F it will open the File menu. Then for "&Print" you would press the P key to open the Print dialog (not ALT+P as the ALT key is only required to open a menu). If the label also includes a CTRL+ option it will list a string such as *\aCtrl+N*. In the example menu section here pressing CTRL+N would create a new file in Visual CADD.

Note that earlier versions of Windows displayed the underlined character on the menus by default. Newer Windows versions hide them until you press and hold the ALT key.

The second item lists the native command that is run when you choose that command from a menu in Visual CADD, for example *FileNew* or *FileOpen*.

**Separator** - creates a separator line in the menu.

## Standard Menu Elements

Standard menu elements are used in all configuration files that define menus. These files include *vcmmu* files, *vcpop* files and *MouseMnu.vcdef*.

There are two standard elements. The `<Menu>` element is used to define the contents of menus. The `<Command>` element defines native and custom commands that are available while the menu is loaded.

The `<External>` element can be used to insert the content of an external menu file (the TriTools toolkit menu is one example) to an existing menu. If only the file name is specified and the file's path is not, the current Menus folder is searched for the file. If the name has no extension then *.vcmmu* is appended. If an Addon attribute is specified, the folder where the addon is located is searched for the file.

```
<Menu>
<Item Label="Menu Text" Command="Native"/>
<Separator/>
<Popup Label="MenuText"/>
<Item.../>
...
</Popup>
<External File="File name" Addon="Addon name"/>
...
</Menu>
<Commands>
standard command elements
</Commands>
```

# Customizing Context-Sensitive Right Mouse Menus

---

Context-sensitive popup menus display when you right click with the mouse while a tool is running (another option is to specify SHIFT+RIGHT CLICK from the *System2* dialog on the Settings menu if you want to assign a snap or other tool to the right mouse click). These menus contain a list of commands that are specific to the tool you are using. For example, with the Single Line tool popup you can toggle Ortho constraint on or off, set the Ortho Angle, start the Tracking command, and run any of the Zoom and Snaps commands.

In earlier versions, there were dozens of *pop* files, one for each command. In version 6 they have been consolidated in the XML file *Mousemnu.vcdef*, to make customizing popups easier to manage. The format is generally the same as the main menu file discussed earlier, with a couple of differences as described below. The following example shows the start of the *Mousemnu.vcdef* file and the popup menu for the Leader command, and then the elements that close the file:

```
<PopupMenu>
<Command Name="LEADER">
<Menu>
<Item Command="Penup"/>
<Item Command="DimLeadSet"/>
<Item Command="DimArrowSet"/>
<Item Command="DimTextset"/>
<Separator/>
<Popup Label="&Zooms">
<Item Label="&All" Command="ZmAll"/>
<Item Label="&Window" Command="ZmArea"/>
<Item Label="&In" Command="ZmIn"/>
<Item Label="&Out" Command="ZmOut"/>
<Item Label="&Pan" Command="ZmPan"/>
<Item Label="&Selected" Command="ZmSel"/>
<Item Label="Previo&us" Command="ZmPrev"/>
<Item Label="&Redraw" Command="Regen"/>
</Popup>
<Popup Label="&Snaps">
<Item Label="&Object" Command="SnObject"/>
<Item Label="&Midpoint" Command="SnMidPt"/>
<Item Label="&Intersection" Command="SnIntersect"/>
<Item Label="Perpendic&ular" Command="SnPerp"/>
<Item Label="&Tangent" Command="SnTangent"/>
<Item Label="&Closest" Command="SnClosestPt"/>
<Item Label="&Percentage" Command="SnPercent"/>
<Item Label="Ce&nter" Command="SnCenter"/>
<Item Label="&Quadrant" Command="SnQuad"/>
<Item Label="Paralle&l" Command="SnPara"/>
```

```
</Popup>
</Menu>
</Command>
....
....
</MouseMenu>
```

The elements `<MouseMenu>` and `</MouseMenu>` respectively define the start and end of a popup menu.

The `<Command Name>` tag starts a new popup menu section and `</Command>` ends it.

## External Popup Files

Although we encourage you to put all popup information in one file, you can create external popup menus and add them to the end of the *MouseMenu.vcdef* file. Third party developers use this for their custom commands (the TriTools Toolkit is one example).

Right-click popup menus can be defined in three ways:

1. Popup menu is defined inline in *mousemenu.vcdef*.
2. Popup menu is defined in an external *vcpop* file. The first `<PopupMenu>` element encountered in the file is used.
3. Popup menu is defined in an external *vcpop* file and a user selected `<PopupMenu>` element is used.

The XML structure is:

```
<MouseMenu>
<Command Name="Native" File="Mypop.vcpop" PopMenu="MyMenu">
Standard menu elements
....
....
</MouseMenu>
```

The `Name` attribute is required and specifies the `Native` or `Custom` command that the popup menu applies to.

The `File` attribute is optional and specifies an external *vcpop* file that contains the popup menu. If `File` is not included, standard menu elements can be used to define the popup menu.

The `PopMenu` attribute is optional and specifies which specific `PopupMenu` element in the *vcpop* file should be used. If `PopMenu` is not included, the first `PopupMenu` element in the external *vcpop* file is used.

# Customizing Toolbars

---

You can easily rearrange or add new command icons on the main toolbar and side toolbar. The commands displayed on these bars are listed in the files *mainsbar.vcmbr* and *toolpal.vctbr*, respectively. These files are found in the Visual CADD 6 *Systems* folder, installed by default to My Documents.

To edit the toolbars, start the new Configuration Editor on the Utilities menu. Select File>Open VCADD File and then either Main Speedbars or Toolpals (the side menu).

You can create custom mainsbars and toolbars and change between them and the default from within Visual CADD by right clicking on the particular toolbar. To do this, create a new XML file with the *.VCMBR* or *.VCTBR* extensions, and add the file to the *System* folder. Then, whenever you right click on the mainsbar or toolbar, the new toolbar will show in the list. Select it and the toolbar is now the active one.

## Main Toolbar

The following listing in *mainsbar.vcmbr* or your custom *.vcmbr* file would first display a row of command icons for the File New, File Open, File Save, and Print commands, respectively. The Separator adds a vertical bar between sets of commands. The Group element denotes a flyout, where the display of all buttons in the group expands when you hold down the left mouse button while hovering over the icon:

```
<ToolbarFile>
<Toolbar>
<Item Command="FileNew"/>
<Item Command="FileOpen"/>
<Item Command="FileSave"/>
<Item Command="FilePrint"/>
<Separator/>
<Group>
<Item Command="CBCut"/>
<Item Command="CBCopy"/>
<Item Command="CBPaste"/>
</Group>
....
....
</Toolbar>
</ToolbarFile>
```

The first two items define the toolbar format required with XML. Note the corresponding tags at the end of the file (with the "/" preceding the tags). This is the method to complete and close XML files.

The other items apply a tag or *element* preceding the Visual CADD native File commands.

## Side Toolbar

The following listing in *toolpal.vctbr* or a custom *.vctbr* file create command icons in the side toolbar. Here again, the Group element denotes a flyout, where the display of all items in the group expand when you hold down the left mouse button while hovering over the icon:

```
<ToolbarFile>
<Toolbar>
<Group>
<Item Command="LineCont"/>
<Item Command="LineSingle"/>
<Item Command="LineDbt"/>
<Item Command="MultiLine"/>
<Item Command="MIDLINE"/>
<Item Command="Point"/>
</Group>
....
....
</Toolbar>
</ToolbarFile>
```

You can rearrange buttons, or add as many command buttons in the vertical toolbar and flyout menus as will fit on the screen.

---

**Tips** See the Help file topic *Customizing Command Buttons* and the tips section there for a wealth of detailed information on setting up and using custom toolbars.

---

### To edit an existing or create a new custom toolbar or mainsbar:

1. Open the Configuration Editor from the Utilities menu.
2. From the File menu select Open VCADD File and then click either Main Toolbars or Toolpals for a list of the top or side bars respectively.
3. Open a file to edit and make changes, or use one of the existing *.vcmb* or *.vctbr* files as a basis to create a new file, using SaveAs to create the new file and file-name.
4. Rearrange, add and/or delete commands in the the file. For a list of Native Commands, see Appendix A. For a list of Custom Commands, see the tab of the same name on the Utilities>Assign Script dialog.
5. Save the file when you have completed making changes.
6. Open Visual CADD. Depending on what type of toolbar you created, right click on either the top or side toolbar, and you will see your new toolbar listed.
7. Click on it and it will be loaded as the current toolbar.
8. To make the new toolbar “stick” the next time you open Visual CADD, run the *Save Current Environment* (EN) command from the Utilities menu.

# Creating New Hatch Patterns

---

You can rename and modify existing hatch patterns, or create your own from scratch.

All of the hatch pattern definitions are contained in an XML file named *hatches.vchat*, located in the *System* folder. To create a new hatch or add an existing one from other sources, you would edit this file and format the new hatch info with the pertinent settings as described below.

In Visual CADD 6 all customizable files have been changed from the old ASCII format to the XML format. You open and edit XML hatch files with the new Configuration Editor found on the Utilities menu. If you have a customized hatch file in the old format (*.hat*), the editor includes the option of converting your earlier ASCII files into the new format. You can also convert the many hatch files available in the public domain (see the Tip at the end of this section), and then copy and paste the information for a particular hatch that you want into the *hatches.vchat* file.

A Visual CADD hatch definition consists of a family of dashed or solid lines, each at a user-defined angle. These lines are then copied and extended (and the dashed pattern repeated as necessary) to fill the hatched area. The hatch definitions are in the following format (hatch definitions define the hatch pattern as it would appear if drawn at a hatch scale factor of 1 and hatch rotation of 0°):

```
<Hatch Name="goes here" Verbatim="">
<!--a comment line to describe the hatch-->
<Line StartX="" StartY="" Angle="" OffsetX="" OffsetY="">
<Dash>1</Dash>
<Space>2</Space> ...
</Line> ...
</Hatch>
```

Note that the hatch name and comment line precedes the actual hatch line definitions, which are enclosed within the set of brackets. There is no limit to the number of lines that can be included in a hatch definition, although more lines means slower hatching times.

The hatch definition parameters are defined as follows:

**HatchName** - name of the hatch pattern. Up to 32 characters are allowed.

**Verbatim** - while hatch names are often used to represent patterns of no real world size or scale, often they are used to represent real world items that have a scale, such as bricks, tiles, or rocks. Visual CADD typically "normalizes" any hatch pattern unless the Verbatim option is used in the definition. Normalizing a hatch involves reducing all numbers in the hatch definition to numbers less than 1. In the case of an 8" brick however, this is not necessarily a good thing, so the Verbatim option is supplied to instruct Visual CADD to use the hatch definition as is, i.e. to not normalize

it. To declare a hatch pattern as verbatim, include a "Verbatim" attribute with a value of "Yes" in the hatch definition.

**Comment** - can be added anywhere using standard XML comments. Note the `!--` preceding the comment, which means that the text following will not be used in calculating the hatch.

**StartX** - is the X coordinate (in "real world" inches) of the start of the line relative to the "origin" of the hatch pattern.

**StartY** - is the Y coordinate (in "real world" inches) of the start of the line relative to the "origin" of the hatch pattern.

**Angle** - is the angle of the line ( $0^\circ$  is at the "3 o'clock" position, and positive is counterclockwise).

**OffsetX** - is the the X component (in "real world" inches) of the offset between copies of the line, in the frame of reference of the line. If the line is rotated  $90^\circ$  (to vertical), for example, then the X offset of the line is equivalent to the Y offset in the "absolute" reference frame of the overall hatch pattern.

**OffsetY** - is the Y component (in "real world" inches) of the offset between copies of the line, in the frame of reference of the line. If the line is rotated  $90^\circ$  (to vertical), for example, then the Y offset of the line is equivalent to the X offset in the "absolute" reference frame of the overall hatch pattern.

**DashLength** - is the length (in "real world" inches) of a solid line segment making up part of the line pattern. The total number of dashes and spaces cannot exceed 16. You can start the line pattern with a dash or space. Note: if this hatch line is a solid, continuous line, skip this and all subsequent parameters on this line.

**SpaceLength** - is the distance (in "real world" inches) between the end of one dash segment and the beginning of the next. The total number of dashes and spaces cannot exceed 16.

### Example:

The following hatch pattern is for standard brick in running bond pattern:

```
<Hatch Name="StdBrickRun" Verbatim="yes">
<!--Standard brick (running bond, 8" long, 2-2/3" high)-->
<Line StartX="0" StartY="0" Angle="0" OffsetX="0" OffsetY="2.666667"/>
<Line StartX="0" StartY="0" Angle="90" OffsetX="2.666667" OffsetY="4">
<Dash>2.666667</Dash>
<Space>2.666667</Space>
</Line>
</Hatch>
```

The first line after the name and comment is the continuous, solid horizontal line that represents the top and bottom of the bricks. It starts at the origin of the hatch pattern (thus the first two 0's) and is horizontal (angle = 0). This line is repeated vertically every 2-2/3" (hence the 2.666667 offset). Because the line is solid, there are no parameters for dash and space segment lengths.

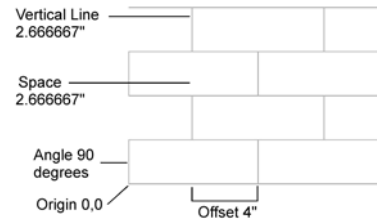

The second line represents the vertical faces of the bricks. This line starts at the origin (thus the first two 0's) and is vertical (angle = 90). The line is copied horizontally every 8" (hence the 4" offset). The line pattern is defined by a solid segment 2-2/3" long (hence the first 2.666667), and a "blank" or space segment also 2-2/3" inch long (hence the final 2.666667).

The best way to understand how hatches work is to open and print the *hatches.vchat* file, and compare the individual hatch definitions with the appearance of the hatch onscreen in Visual CADD.

---

**Tip** You can find a great assortment of custom hatches at the Yahoo user group website. Go to <http://groups.yahoo.com/> and type Visual CADD in the Search box.

---

## Creating New Line Types

---

You can rename or modify the line types that come with Visual CADD, or create new ones. A maximum of 256 line types is available.

All line type definitions are contained in an XML file named *linetype.vclnt*, located in the System folder.

The line type definitions do not have to appear in order in the *linetype.vclnt* file, as the index number specifies where it appears in the list when loaded into Visual CADD.

Here is an excerpt from the default XML file that ships with v6 showing the format using a *dashed* line as an example:

```
<Linetype Name="DASHED" Index="10" Ref="Device" Align="Balanced">
<Line>
<Dash>0.24</Dash>
<Space>0.08</Space>
</Line>
</Linetype>
```

**Linetype Name** - the name of the pattern to be displayed in all Linetype list boxes in the interface. Up to 32 characters are allowed. Spaces are not permitted in the name. The name must be unique. If a name is used multiple times, the index and definition associated with the *last* appearance of the name will be used.

**Index** - the linetype number (0-255). While line names are optional, all linetypes must have a unique number.

**Ref** - reference frame for measuring the lengths of the solid and blank segments that make up a custom line type. Choices are the *world* reference frame or the *device* reference frame. If the world option is chosen, then the segment lengths are measured in the same reference frame as the drawing objects themselves. Thus the apparent "size" of a world-reference pattern will change when you zoom in or out on-screen, or when you plot or print at different scales. If the device option is chosen, then the segment lengths are measured in the reference frame of the computer screen, printer, or plotter. The apparent "size" of a device-reference pattern will remain constant on-screen and on paper regardless of the zoom factor or print scale.

All of the 49 linetypes that ship with Visual CADD 6 are the device type.

**Align** - during different views or when lines are drawn at specific lengths, the ends of line segments may not fall on a solid segment of a line definition. Because of this there is a provision built into Visual CADD that allows the explicit line type definition to be overridden in these cases. By using the *Balanced* option, Visual CADD will always "cap" the ends of lines with a solid segment regardless of the line definition and where the end of the line falls within that definition.

**DashLength** - the length in inches of a solid line segment making up part of the pattern. The length is measured in "real world" inches if the World reference is specified, and on-screen or printed inches if the Device reference is specified (see Ref, above). A dash is indicated as a positive length. To include a dot as part of the pattern, specify a length of 0. The total number of dashes, dots and spaces cannot exceed 16. You can start any line type with a dash, dot or space, and the pattern will begin at the starting point of any line you draw with that line type.

**SpaceLength** - the distance between the end of one dash segment or dot and the beginning of the next. The length is measured in "real world" inches if the World reference is specified, and on-screen or printed inches if the Device reference is specified (see Ref, above). Spaces can either be defined with a <Space> element, in which case the value should be positive or with a <Dash> element, in which case the value should be negative. There is no difference between the two formats. To include a dot as part of the pattern, specify a length of 0. The total number of dashes, dots and spaces cannot exceed 16. You can start any line type with a dash, dot or space, and the pattern will begin at the starting point of any line you draw with that line type.

## Example:

The following custom line type is for a property line. The line type definition is as follows:

```
<Linetype Name="PROPLIN" Index="51" Ref="Device" Align="Balanced">
<Line>
<Dash>2</Dash>
<Space>.06</Space>
<Dash>.03</Dash>
<Space>.06</Space>
<Dash>.03</Dash>
<Space>.06</Space>
</Line>
</Linetype>
```

We have named it PROPLIN as it is a pattern often used when drawing property lines in survey work and plot or site plans. The index number of 51 means that it will appear at the end of the list of the 49 default linetypes shipped with Visual CADD 6.

The pattern starts with a 2" long solid segment followed by a .06" long blank space, then a .03" long solid segment, then another .06" long blank space, then a .03" long solid segment, then another .06" long blank space. This is a *Device* reference line type, which means that it will always appear the same size on screen and on paper. The *Balanced* alignment instructs Visual CADD to always end lines with solid segments.

---

**Tip** For a complete listing of the 49 predefined linetype definitions in Visual CADD, see the *Guide to Linetypes* topic in the Help file. It provides some background on the history and/or intended use of each linetype.

---



## WORKING WITH OTHER APPLICATIONS

In hand drafting, using information from one drawing in another involves drawing it again, or duplicating a portion of the drawing and then cutting and pasting on a layout table. Visual CADD provides tools that allow you to share information with other drawings and with other Windows applications outside the VCADD environment quickly and easily.

You can exchange drawings with users of AutoCAD and Generic CADD, and you can create graphical illustrations to export for use in other applications. You can also import text created in other applications directly into your Visual CADD drawings.

Using the Windows clipboard is the easiest way to share information among applications.

With the Microsoft feature Object Linking and Embedding (OLE), you can link Visual CADD drawings to files in other applications so that changes you make to the Visual CADD file are updated in the file it is linked to. Alternately use the clipboard Copy command to embed CADD objects by Pasting them directly into the other application.

You can also use OLE to embed or link other files such as word processing documents and spreadsheets with Visual CADD, displaying the contents of those files in your drawing.

### Copying Objects Between Visual CADD Drawings

---

Because Visual CADD allows you to have multiple drawings open at the same time, sharing information between them is easily done via the clipboard.

#### **To copy Visual CADD objects to another drawing:**

1. In the first drawing, select the Visual CADD entities you want to duplicate.
2. Select Edit>Copy.
3. Switch to the second open drawing from the Window menu or by pressing CTL+TAB, and select Edit>Paste.
4. A bounding box will be attached to the cursor. Place the copied objects at the desired location with a mouse click.

## Merging Two Visual CADD Drawings

---

Use the Merge command to combine the contents of two drawings. The name and drawing environment of the first drawing loaded are preserved, although symbols and attributes of the second drawing are added to those of the first (conflicts such as duplicate symbol names are resolved in favor of the first drawing).

### To merge another drawing file into the current drawing:

1. Select File>Merge. The files that you are trying to merge must both be *VCD* files.
2. If necessary, change the path and drive in order to locate the file you wish to merge.
3. In the list box, double click the file name, or select the file name and click [Open].
4. A bounding box containing the contents of the merged file will be attached to the cursor. Place the merged drawing at the desired location with a mouse click.

## Copying Between Visual CADD and Other Applications

---

Incorporating parts of Visual CADD drawings into other Windows based documents is simple. You can use the standard cut, copy, and paste commands to add Visual CADD illustrations to your spreadsheets or word processing documents. You can also use layout and publishing software to combine Visual CADD drawings with other text and graphic elements for visually appealing publications.

To share text between Visual CADD and another application you use the Text Editor tool.

### To copy Visual CADD objects to another application:

1. Select the Visual CADD entities you want to use in another application.
2. Select Edit>Copy.
3. Switch to the other application, and select Edit>Paste.

---

**Note** Visual CADD entities copied to the clipboard are pasted into other Windows applications as a Visual CADD 6 Object (OLE). This results in a high quality image at different resolutions.

---

### To import text from another application:

1. Within the other application, select the text you want to use.
2. Select Edit>Copy.
3. Switch to Visual CADD, and then click the Text Editor tool. 

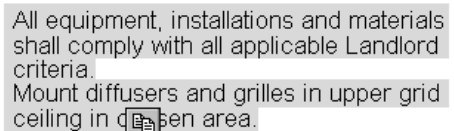

All equipment, installations and materials shall comply with all applicable Landlord criteria.  
Mount diffusers and grilles in upper grid ceiling in dashed area.

4. Select a point on the drawing at which to insert the text.
5. In the Text Editor box, right click and select Paste.
6. Click [OK] to place in the drawing.

Alternately you can load the entire contents of an ASCII file (for example a *.txt* file) from within Text Editor. Start the tool, click on a placement point in the drawing, and then click the [Load ASCII File] button in the dialog. Choose a file and click [OK]. The file content is now loaded into the Text Editor window, ready for editing and/or placement in your drawing.

To bypass Text Editor and load the text file directly into the drawing instead, select *Load Text File (LA)* from the Text section of the Draw menu. Choose a file, click [OK] to close the dialog, and a bounding box containing the text is attached to your cursor. Left click to place it in the drawing.

---

**Tip** You can use OLE to import non-ASCII text from programs such as Word and Wordperfect.

---

#### To use Visual CADD text in another application:

1. In Visual CADD, select a text block, and then click the Text Editor tool.
2. In the Text Editor box, select the text you want to export, then right click and select *Copy*.
3. Open the other application, and then select Edit>Paste.

All equipment, installations and materials shall comply with all applicable Landlord criteria.  
Mount diffusers and grilles in upper grid ceiling in  open area.

## Linking and Embedding Objects (OLE)

---

OLE is a method to transfer and share information between Windows applications by including data created in one application into a document created in another application. Visual CADD 6 works with OLE in both directions; you can paste or insert VCADD drawings into another application *if* it supports OLE, and you can paste or insert the contents of a graphic, spreadsheet or word processing file into Visual CADD.

The application that sends the information to the second app is often called a *server*. The application receiving the information is called a *client*, or *container*.

Data from other applications can be brought into Visual CADD using one of two methods. *Paste Object* takes objects on the clipboard and pastes them into Visual CADD as an OLE object. Examples might include several selected paragraphs of a word processing document, or a range of cells in a spreadsheet.

Use *Insert OLE Object* to insert the entire contents of a file from another application into Visual CADD. You choose an object type (for example, an Excel or WordPerfect file), and whether to insert an existing file on disk or a brand new file.

Both commands work only if the application you are copying data from supports Object Linking and Embedding (OLE). If you copy information to the clipboard from the non-OLE program and then try to paste it into Visual Cadd, *Paste Object* will be greyed out and not available from the Edit menu. If you try to insert an object from a non-OLE server, you may only see an icon in the drawing, representing the object type, or an error message telling you the insert was not successful.

*Insert OLE Object* allows you to either link or embed the object; *Paste Object* always places an embedded object.

The difference between embedded versus linked has to do with where the native data is stored. We'll use a Microsoft Excel spreadsheet as an example. Embedded stores the native Excel data into the VCADD drawing (in the VCD file), whereas linked stores a path to an Excel sheet and the native Excel data stays in that file (an XLS).

Either way, the object is editable. Changes made to an embedded Object are saved in the VCD file. Changes made to a linked Object are saved in the original file, and the view is updated in Visual CADD to reflect the changes.

Because an OLE Object is a special type of Windows object, the Visual CADD commands have no affect on it. You can't snap to the OLE Object, or use Rotate or any of the Copy commands.

OLE Objects are placed in the upper left corner of a Visual CADD drawing. To move it, select the Object by clicking on it, hold down the left mouse button, and drag it to another location. If you use a line tool as your default, click the Selection arrow on the side toolbar (or type SE), then select the Object.

You can change the size of the OLE Object, the layer it appears on, and the draw order as it relates to other OLE Objects and all Visual CADD objects, by selecting the Object, right clicking and clicking *Properties* to open a dialog.

### **To paste objects on the clipboard from other applications into Visual CADD:**

1. Use the Copy command in the other application to copy the objects to the clipboard.
2. Choose the Paste Object command.

The clipboard contents are pasted into the drawing. The contents remain on the clipboard, ready to be placed into the current or another VCADD drawing, or another Windows application that supports OLE. The information remains on the clipboard until you clear it, place new objects on it with Cut or Copy, or exit Windows.

### **To Insert an OLE Object into Visual CADD:**

1. Start the Insert OLE Object command from the Edit menu.

2. On the Insert Object dialog that appears, choose whether you want to insert a new Object or an existing file.
3. If you choose *Create Object*, pick from the Object Type list.  
Note that the list shows all object types on your computer. Some types might not be applicable for creating a new object inside the Visual CADD environment.
4. If you choose *Create from File*, click [Browse] and navigate to the folder containing the file. Select it and press [Open].  
Note that by default the file information will be embedded. If you want to link to the file instead, check the Link box.
5. Click the [OK] button.

By default, when the Object is inserted into the drawing a *Properties* dialog pops up allowing you to edit the OLE Object. If you don't want this behavior, uncheck the *Display dialog while inserting* box at the bottom of the dialog, and do an Environment Save (EN) so that this setting "sticks" next time you open Visual CADD.

## Creating Export Files

---

If the application you are using does not support the Windows clipboard, you can create an export file containing the graphic information, and then place that file in your application.

The Windows metafile format is the most flexible, as it supports line-weight control as well as filled entities, and displays on the screen what you will see in print. The encapsulated Postscript (EPS) format allows line-weight control and filled entities, but most applications will not display the graphic object until you print. The Hewlett Packard graphics language (HP-GL) format is the least flexible as it does not support lineweight control and it uses parallel lines to approximate filled entities. HP-GL also cannot be displayed for preview by most applications but may be used if the other formats are not available in your application.

Creating a metafile is as simple as saving a file in the proper format. Creating EPS and HP-GL files requires that you set Windows to send printer or plotter output to a file.

If you use this method, remember to set printer output back to a port when you are done, or you will be unable to print to a physical printer. You can simplify this process by setting up a separate printer description for each type of output that you use by using the Add Printer wizard in Windows. For further information about setting up different printers, see your Windows documentation.

---

**Tip** To export only part of a drawing, select those entities to be included in the export file, and then check Save Selected in the Save As dialog.

---

## File Format Differences

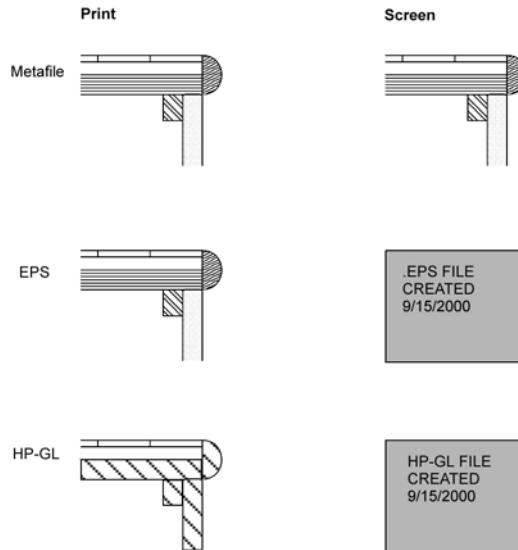

### To create a Windows metafile:

1. Select File>Export>Images.
2. Select WMF/AFM or EMF from the Image Type dropdown and then click the [Save Image] button.
3. Specify a file name, and click [Save].

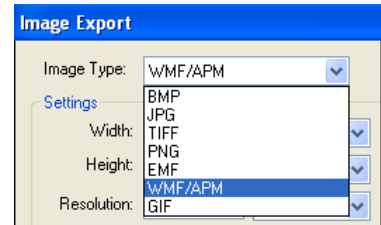

### To create an encapsulated Postscript (.eps) file:

1. Select File>Print.
2. In the Print dialog, select a printer that supports Postscript.
3. Change settings as desired for Scale, Rotation etc.
4. Tick the *Print to File* checkbox and click [Print].
5. In the Print to File dialog, type a filename and click [Save]. In Windows Explorer (file manager), rename the file extension to .eps.

### To create an HPGL file:

1. Select File>Plot.
2. In the Plot dialog Plotter list select *Default Settings for HGPL Plotters*.
3. Change settings as desired for Scale, Rotation etc
4. Tick the *Plot to File* check box and click [Plot].
5. In the Plot to File dialog type a filename, select a file type, and then click [Save].

# Sharing Files with AutoCAD and Generic CADD

---

Visual CADD can read and write both AutoCAD and Generic CADD file formats. Because the three applications support different features, some objects and information might not be translated.

For instance, because of the way Generic CADD was originally written, hatches do not import into Visual CADD at all but instead are converted to either a symbol or a single Visual CADD hatch pattern, depending on choices you make in a settings dialog.

AutoCAD's Paper space viewports are imported as bound reference frame entities. Although Visual CADD does not use AutoCAD's Extended Entity Data, it will store it with a drawing and include it if the drawing is translated back into the AutoCAD format. You have access to Extended Entity Data through Visual CADD's programming interface.

Version 6 imports and exports AutoCAD files from R12 through R2009. Newer DWG formats will be supported by v6 update patches. Check at [www.tritools.com](http://www.tritools.com).

When you "open" an AutoCAD or Generic CADD drawing, it is not opened in its native format. For example, if you open a DWG, each object will be converted into its Visual CADD equivalent. Your original DWG file at this point is still intact and unchanged.

However, if you modify the drawing in VCADD and then select the Save command, the file is converted back to the DWG format and saved, overwriting the original with the changes.

If retaining the original file is important, use the SaveAs command instead to save the file with the same name in the VCD format, or with a different name in the DWG format.

## **To open an AutoCAD or Generic CADD drawing in Visual CADD:**

1. Select File>Import>CADD Files.
2. In the Open File dialog, click the Files of Type list, and then select either AutoCAD (.dwg) or Generic CADD (.gcd).
3. Select the file to open.
4. Click [Open].

## **To save an open AutoCAD or Generic CADD drawing to the original format:**

1. Select File>Export>CADD Files.
2. Click the Files of Type dropdown list, and then select either AutoCAD (.dwg) or Generic CADD (.gcd).
3. Specify the folder and filename in which to save the file.
4. Click [Save].

---

**Tip** Unlike earlier ACAD versions, R2000 and later DWG files are automatically created with one empty layout space (a layout view is the same as a Paper Space view). If this view is empty, Visual CADD won't load it. If the Layout Space contains data, that view opens and you are prompted to save the Model Space file that links to the view.

---

## Converting AutoCAD Xrefs and Paper Space

---

External references are imported into Visual CADD as linked reference frames, with the option of converting all linked files to .vcd format, or maintaining them as .dwg files.

Linked reference frame entities export to AutoCAD as Xref insert entities. Bound reference frame entities are simply exploded. If the view of any reference frame is not the entire source object, all reference frame entities also map into AutoCAD viewport entities in paper space and the entities are tiled in model space. The AutoCAD paper space drawing appears the same as the original Visual CADD drawing.

---

**Tip** If you open an AutoCAD drawing that contains external references, both the drawing and external reference files must be located in the same folder.

---

## AutoCAD and Generic CADD Translation Settings

---

Although Visual CADD, AutoCAD, and Generic CADD operate differently, you can adjust the way in which certain entities and properties are translated.

### Duplicating Generic CADD hatch patterns

Because of the way Generic CADD defines hatch patterns, they cannot be used in Visual CADD. When converting, you can choose to have Visual CADD replace each hatch with a symbol that looks exactly like the Generic CADD hatch pattern.

However, it is no longer an associative hatch and can't be edited or modified.

Or, you can choose to select a single Visual CADD hatch pattern to apply to all the imported hatches. Once the drawing is converted to Visual CADD, you'll have to go back and edit each hatch to get it to look the same as in GCADD. But the advantage is that all hatches are now associative (they will update when you stretch them, for example) and are completely editable for color, scale and rotation.

### Setting AutoCAD Measurement Units

When converting AutoCAD drawings into Visual CADD, you must identify the unit of measurement in which they were drawn because it is not stored in the DWG files.

## Converting AutoCAD XRefs

When you open an AutoCAD drawing that contains XRefs, you must decide how to treat the drawings to which the XRefs refer. You can either leave them in the AutoCAD format or you can convert them to the Visual CADD format.

## Translating AutoCAD Colors

In AutoCAD, a numbered screen color is mapped to a plotter pen. On pen plotters, the color number is more important than the displayed color. If you use an inkjet plotter, the displayed color itself is often more important. Visual CADD uses color mapping to give you an unlimited choice of options for translating colors between the two programs. A default map is set, but you can also use custom maps for AutoCAD Windows colors, and a Visual CADD default of 1-to-1 (color 0 to color 0, color 1 to color 1, etc.). You can also create and save your own color maps of any combination.

## Importing Fonts Correctly

When you import a drawing, you can choose “Ignore,” and all of the font names used in the drawing will be unchanged in the Visual CADD drawing. But you must first use the Font Converter to translate AutoCAD or Generic CADD fonts into a form that Visual CADD understands before you import the drawing. Once done, the fonts will appear the same in both versions of the drawing.

If you do not have the original AutoCAD or Generic CADD font files, or you do not want to convert them, you can use font mapping to translate AutoCAD or Generic CADD font names into names of fonts available to Visual CADD.

## Generic CADD Translation Settings

This dialog opens when you click on GCD Import/Export Settings on the Utilities menu. For complete details on each setting see the Help file.

- The Hatch section gives you the choice of converting all hatches to a symbol so that they will appear the same in VCADD as they did in GCADD, or converts them all to a specific VCADD hatch so that they can be edited later.
- If Ignore font map is checked, original font names are retained on import rather than using font mapping (more on that later in this chapter).

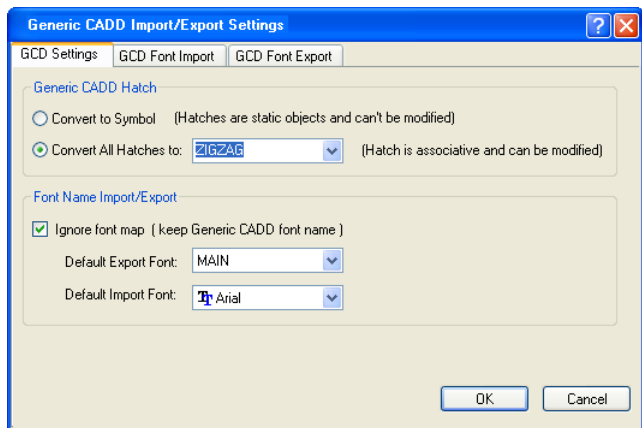

- You set a default font for both import and export so that if no font match is found during the conversion, these fonts are substituted instead onscreen, if there is no font mapping specified. Substituted fonts still retain the original name in the file.

## AutoCAD Translation Settings

This dialog opens when you click on DWG Import/Export Settings on the Utilities menu. For complete details on each setting see the Help file.

- Choose the ACAD version for exporting from Visual CADD.
- Specify whether to convert XRef files or leave as DWG files.
- Specify the method of Symbol conversion when using non-inch numeric settings.
- Specify the unit settings for conversion.
- Specify font mapping options (same as described on the Generic CADD settings dialog above).

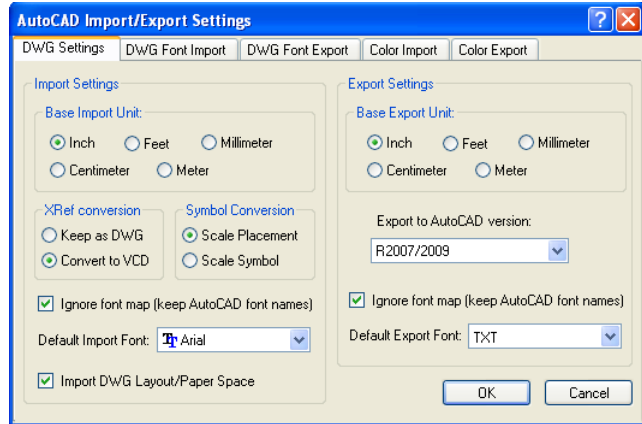

## Adjusting Font Mapping

Visual CADD, AutoCAD, and Generic CADD do not use the same fonts. When converting a file between formats, you must decide how to substitute for fonts that exist in one application but not in the other. You can choose that a single default font be used whenever a font match is not found, both on import or export.

If multiple fonts exist in either the DWG you are importing or the Visual CADD file you are exporting, a more flexible and powerful option is to create font maps to substitute a specific font for another specific font in the other program.

Font maps simply describe the way in which font names are translated during file conversion. For example, you can specify that every time the font named “TXT” is found in an AutoCAD drawing, it is replaced with the font named “Engineer” when the drawing is loaded into Visual CADD.

Font maps can be saved to the folder of your choice, and then reloaded later. This is handy if you have clients or customers with different font requirements. Note that the

file extension is *.fnt* for both the import and export font maps, so the file name itself should reflect whether you are converting in or out of Visual CADD.

If you have an AutoCAD or Generic CADD font name that is not shown on the font list, you can click [Add] to add a new name. The number of fonts on the list is limited to 32. Remove a font name by clicking the [Remove] button.

If you include a font in your font map that is not on the computer, the default font for import and export on the GCD or DWG Import/Export Settings tabs is substituted instead. For example,

suppose you have set Arial as your default import font. If your font map replaces "TXT" from the DWG with "Engineer" in the VCD, but the Engineer font is not found on your system, TXT will map to Arial instead.

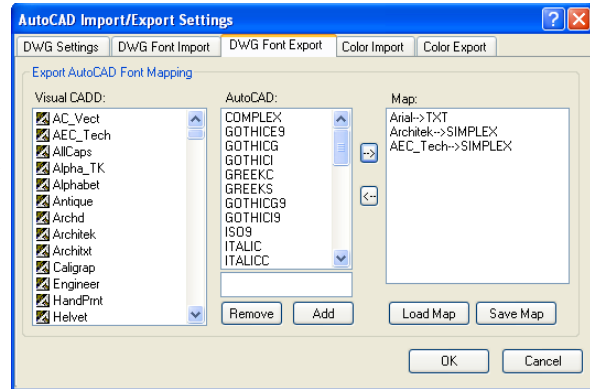

---

**Tip** To avoid the need to translate font names, use the Font Converter on the Utilities menu to translate your AutoCAD and Generic CADD fonts to a Visual CADD vector font.

---

## Adjusting Color Mapping

---

Visual CADD and AutoCAD have very different color indexes. Because AutoCAD maps colors to pen width for printed output, it is often important to retain these colors on drawings that you import and then must export back to consultants or others you share drawing files with. Color mapping provides the ability to match to other color indexes.

Visual CADD 6 uses a default mapping that is an accurate close match between VCADD and ACAD colors. This option is set by default on the tabs for both Color Import and Color Export, and all other controls are greyed out.

### Custom Maps

To use an alternate mapping scheme, click the *Use Custom Map* button. Sample custom maps are provided for both AutoCAD Windows colors and One To One ( DWG color 1 to VCD color 1, etc). But you can also create your own maps for any other combination of colors. The Default map is included in the list. You can't edit this map, but you can use it as the basis of a custom map by clicking the [New Map] button and assigning it a new name. Edit the new map, and when finished click [Save Map].

You can also map linewidth to color, or ignore color mapping on import and force all colors to a particular color that you designate. You can delete any custom map that you create.

### To Create a New Color Map:

1. Select a map in the Map drop-down to use as the basis for your new map.
2. Press the [New Map] button.
3. Enter a name for the new color map and press [OK].
4. The new name is shown as current in the Map dropdown list.
5. In the edit boxes, make changes to Visual CADD colors to correspond with each DWG color. If you want to include linewidth mapping, uncheck the "Ignore" box and type a linewidth to correspond with each DWG color.

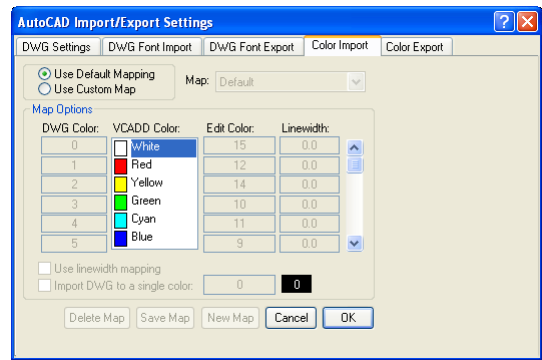

Alternatively, check the "All Colors to:" checkbox and type a color number in the right hand edit box to force all DWG colors to a single Visual CADD color.

6. Press [Save Map] to save the new map and [OK] to finish.

---

**Note** Do an *Environment Save* (EN) to make the custom map current the next time you open Visual CADD.

---

### To Create a New Color Export Map:

1. Select a map in the Map dropdown to use as the basis for your new map.
2. Press the [New Map] button.
3. Enter a name for the new color map and press [OK].
4. The new name is shown as current in the dialog dropdown list.
5. Decide whether to convert color to color or Visual CADD linewidth to DWG color.
6. In the edit boxes, make changes to Visual CADD linewidth and/or DWG colors.
7. Press [Save Map] to save the new map and [OK] to finish.

---

**Tip** Prior to AutoCAD 2000, setting a lineweight property in a DWG was not an option; for printed output a lineweight was mapped to a color in the display. Many AutoCAD users continue to use this method. You can map DWG colors to a Visual CADD linewidth when creating a custom color map, to approximate VCADD's linewidth feature.

---

## PRINTING AND OTHER OUTPUT

Because hand drafting involves recording information directly on paper, no extra process is required to create printed output. You hold the reproducible copy in hand. But when finished, you have limited presentation options. With Visual CADD you can present drawings in many different ways.

For example, you can print your drawings to various printers and plotters. You can print the same drawing at many different sizes and types of media for different types of presentation. You can either have Visual CADD fit the drawing onto the page or you can specify an exact scale if the drawing will be used for technical drawings or construction documents.

Drawings can also be exported from within Visual CADD to another file type, for example as a PDF or XML, and in raster image formats such as BMP or GIF or JPG.

You can save all the settings on the Print dialog as a Preset, and then call up different presets to quickly change paper sizes, orientation, margins and even printers.

If you have an older vector output device such as a pen plotter, Visual CADD provides you with control over line weight that is not available by using the standard Windows printer drivers.

### Printing Your Drawing

---

Printing can be as simple as sizing the drawing to your paper size and then clicking [Print]. If you have more complex requirements, you can adjust Visual CADD's print settings to print the drawing at an exact scale.

Print settings give you control over the size and orientation of your drawing on the page as well as a variety of options for expediting printing and controlling various printers.

Visual CADD's preview window lets you check output before you send it to the printer, and to make changes to margins, orientation, and scale before you do so.

If your computer is not connected to the printer you want to use, you can store the output in an export file for later use.

# Print Settings

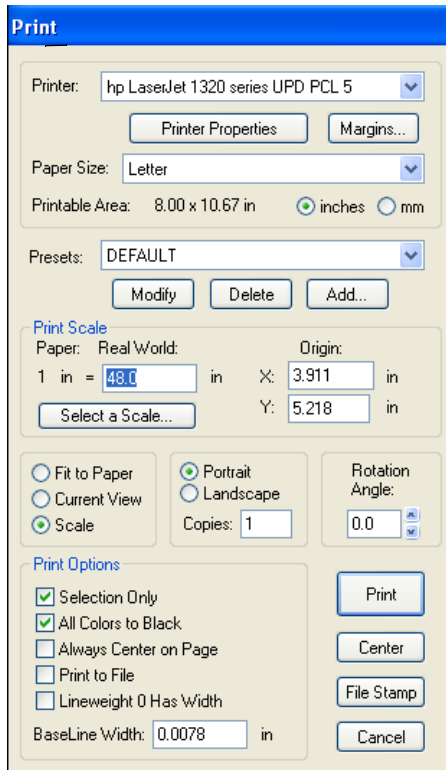

Open the Print dialog from the icon on the main toolbar, from the File menu, or by typing **PR**.

## Printer Settings

Sets the standard Windows printer settings. Choose a printer installed on your machine or network from the dropdown list and set properties, paper size and margin sizes. Also select the unit to measure paper size and margins.

## Presets

Adding a Print Preset takes a "snapshot" of all settings on the Print dialog, which can then be called up at a later time to quickly change all print settings.

## Print Scale and Orientation

Sets the factor by which the drawing will be scaled when the *Scale* option is checked. Use the [Select a Scale] button to choose from a list of common print scales.

The drawing Origin is relative to the lower left corner of the margin. The units of measure are those of the page size and not of the drawing.

Specify whether the drawing is to be scaled to fit the paper size, scaled so that the displayed onscreen view will fill the page, or scaled to a factor that you enter.

Select between horizontal (landscape) and vertical (portrait) page orientation.

Select number of copies to print.

Set the rotation angle of your drawing relative to the paper (zero by default).

## Print Options

**Selection Only** - prints only the entities that have been selected in the drawing.

**All Colors to Black** - prints all entities in black, regardless of their color in the drawing.

**Center on Page** - when checked, drawing is always centered on the page.

**Print to File** - sends the output to a file on the disk drive or network.

**Lineweight 0 has Width** - sets the finest line width in your drawing. Unchecked, Visual CADD prints the finest line your printer can output. Checked, VCADD prints the smallest linewidth as LW0.

**Baseline Width** - sets the base or minimum width for line output from your printer.

In addition to the standard Print and Cancel buttons on the dialog, the Center button will center the drawing on the printed page when the Always Center on Page checkbox is unticked. The File Stamp button opens a dialog to add a date stamp on the printed page's edge. New in v6 you can add a watermark to the background of the drawing from this dialog. See the Help file for more details on the feature.

## Adjusting Print Settings and Options

---

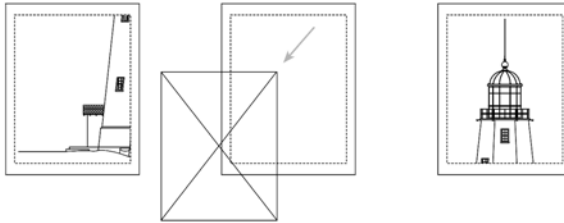

You can change the size of margins by clicking [Margins] on the Print dialog, and then typing new values. Margins can be no larger than the maximum print area defined by your printer. The printer cannot print to the edge of the paper. Often the printer can print no less than 1/4" from the edge of the paper. Page

Size is, at maximum, the actual usable area on the paper for printing.

After changing the Print Scale of your drawing, you can drag the preview into position to display the portion you want to print.

### Common Print Scales:

| Print Scale... | Real World Value... |
|----------------|---------------------|
| 3/32" = 1'     | 1" = 128"           |
| 1/8" = 1'      | 1" = 96"            |
| 3/16" = 1'     | 1" = 64"            |
| 1/4" = 1'      | 1" = 48"            |
| 3/8" = 1'      | 1" = 32"            |
| 1/2" = 1'      | 1" = 24"            |
| 3/4" = 1'      | 1" = 16"            |
| 1" = 1'        | 1" = 12"            |
| 1 1/2" = 1'    | 1" = 8"             |
| 3" = 1'        | 1" = 4"             |

The scales to the left apply if your Numeric Units are set to Inches or Feet and Inches. If your units are set to Feet and you wanted to output at a print scale of 1/4"= 1', the Real world value would be 1"=4'.

The [Select a Scale] button in the *Print Scale* section provides a dropdown list of many of the most often used scales in the architectural and engineering disciplines, in both English and Metric units. Alternately, you can type *any* scale value directly into the Real World scale edit box on the Print dialog.

## Printing options

---

### To print an entire drawing:

1. Select File>Print.
2. Click *Fit to Paper* and then click [Print].

### To print a portion of a drawing:

1. Zoom to display a portion of your drawing.
2. Select File>Print.
3. Click *Current View* and then click [Print].

### To set printing margins:

1. Select File>Print.
2. Click [Margins].
3. Adjust the margin settings.
4. Click [OK] to return to the Print dialog.

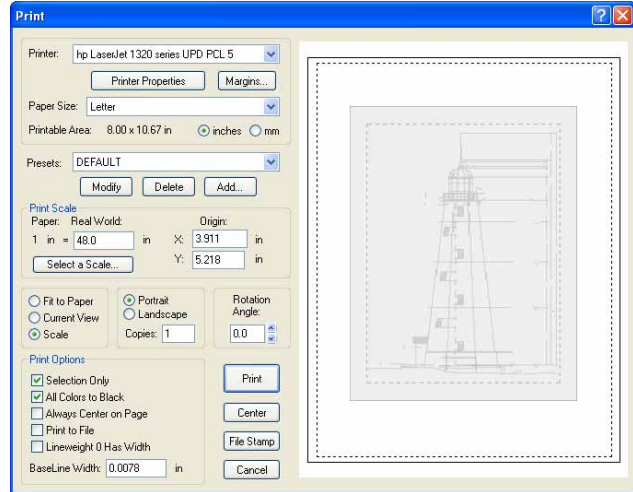

---

**Note** Clicking [Default] in the Margins dialog returns the settings to the default values of the selected printer.

---

### To select a different printer:

1. Select File>Print.
2. Click the down arrow in the Printer box at top of Print dialog to dropdown the list that shows available printers.
3. Choose a printer from the list to make it current.
4. Click [Print Properties] if you want to modify settings for that particular printer. This opens the typical Windows dialogs as installed by the printer manufacturer .
5. After making changes click [OK] to return to the Visual CADD Print dialog.

### To create a print file:

1. Select File>Print.
2. Check *Print to File*, and then click [Print].
3. Type a name and folder in which to save the print file, select a file type, and then click [Save].

# Print Presets

---

If your printing output often includes changes to settings such as paper size, scale and different printers, you know how time consuming it can be to set each individual option. Visual CADD lets you take a "snapshot" of all the settings on the Print dialog, saving them for later use. One way to think of presets is as a print "style". Once you add a preset, it can be called up quickly from a list on the Print dialog.

Presets can be modified or deleted at any time.

## To Add a Preset:

1. Make changes to the Print dialog settings as desired.
2. Click the [Add] button in the Preset section of the Print dialog.
3. Enter the name of your new Preset, and press [OK] to finish.

---

**Note** You can use almost any character in naming Presets. The exceptions are quotes (") and apostrophe ('). Maximum length is 79 characters; spaces between words are OK.

---

## To apply a Preset:

1. Open the Print Dialog by selecting File>Print or typing **PR**.
2. In the Preset dropdown list, choose Default or any of the Presets that you have created.
3. Press the [Print] button to print the drawing.

---

**Note** Change any setting after applying a Preset, but before printing your drawing, and it will affect the current print. If you close the Print dialog without clicking the Modify button to save the changes, they will not apply next time you use that Preset.

---

## To Modify a Preset:

1. Make sure the Print Preset that you wish to modify is current in the preset dropdown.
2. Make changes to the settings on the Print dialog as desired.
3. Click the [Modify] button.

## To Delete a Preset:

1. Pick the Preset that you wish to delete from the preset dropdown.
2. Click the [Delete] button.

---

**Note** The Default is not really a Preset at all--it doesn't work the same as any of the Presets that you create. With Default applied, if you make changes in the dialog and then Print, those changes will also apply next time you open the Print dialog.

---

# Output as PDF

You can export drawings directly from Visual CADD to the *Portable Document File* format and share them with your customers. PDF files preserve the look and integrity of your Visual CADD drawings, and you can share them with anyone electronically, regardless of hardware and software platforms.

PDF files are compact and complete, and can be shared, viewed, and printed by anyone with the free Adobe Reader software. A copy is included on the version 6 CD; you can also download the Reader at [www.adobe.com](http://www.adobe.com). If your customers have the full Adobe Acrobat software, they can redline the drawings and return them for revisions.

Visual CADD creates vector PDF output; this results in much higher quality files than those created by PDF writers that produce raster (bitmap) files.

PDF output from Visual CADD also has optional security features to protect sensitive drawings. If desired, you can set password protection for opening files, as well as individual permissions for printing, editing and copying.

Although several of the settings options are unique to PDF, the PDF Export dialog will be familiar to you because the layout is based on the *Print* dialog, as shown in the illustration at right. You can save all of a drawing or a selection to PDF, and scale the output or fit to the paper size (that the PDF will ultimately be printed to). You can take a snapshot of settings and save them as a PDF Preset.

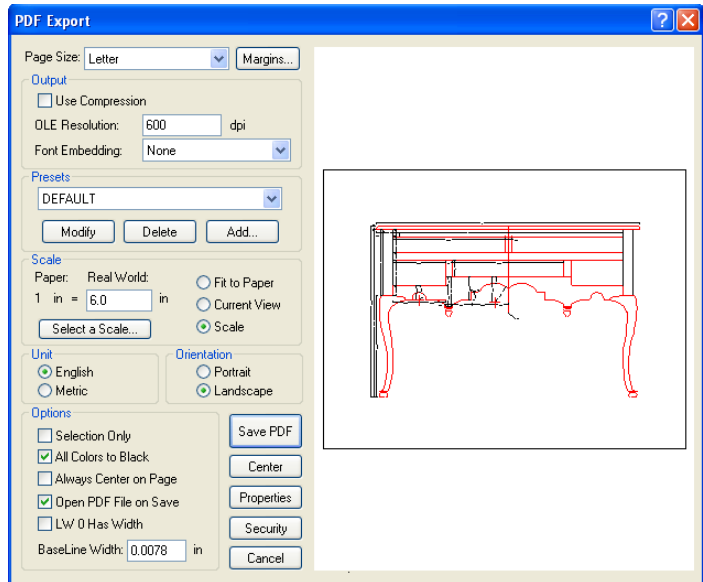

A list of default page sizes is included, but at the bottom of that list is the option to open a dialog and create custom pages sizes or edit the existing ones. You can also adjust Margins for a particular page size and save the configuration as a Preset.

There is an option to use compression, which will reduce file size significantly. We recommend that you use it; because the PDF is saved in vector format, the quality of the output will not suffer with compression applied.

A new feature for v6, available from the Properties button, is the ability to export Visual CADD layers with the PDF file. If your PDF viewing software supports layers, you can display and hide layers both onscreen viewing and with print output.

**Tip** Be careful about outputting a PDF file that contains OLE Objects if you intend to transfer it to clients electronically. The Object is saved as a bitmap in the file, and depending on the size of the Object and the resolution, PDF files can become quite large. Experiment with the OLE Resolution setting to reduce file size.

## Output as Image

You can export vector based Visual CADD drawings to a raster image file format so that they can be used for display on websites or in printed materials such as brochures, reports and other documents. The *Image Export* dialog has a wide range of settings to help you control the image type, size and other options for image output.

There are 7 choices for image type: GIF, PNG, JPG, BMP, TIFF, EMF and WMF. The first three are highly compressed and are suitable for the Internet due to smaller file sizes. PNG is the functional equivalent but improved version of GIF and is supported by modern web browsers. JPG is a popular format and works well on photographs, naturalistic artwork, and similar material, but it is usually not the best choice for line drawings such as CADD files.

The other formats are more suitable for printed applications due to larger file sizes (but higher quality images). TIFF is a long established choice for artwork in publications; all illustrations in this Users Guide are TIFF files.

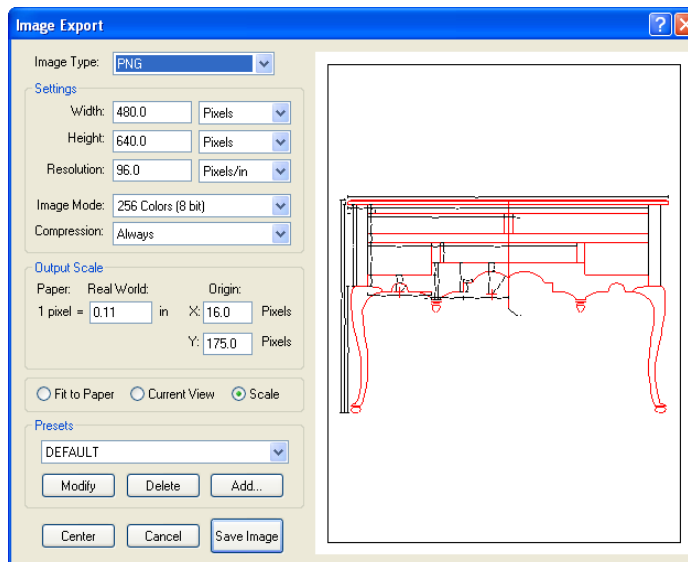

EMF and WMF are included as legacy formats; they were used in early versions of Visual CADD and date back to Windows 3.1 thru Windows XP. EMF is an enhanced version of WMF. We recommend that you export to the newer graphic formats.

The Help file topic *Image Export* provides more detailed information on each format, as well as a

detailed description of the settings on the dialog as they apply to the particular image types.

Although many of these settings options are unique to raster images, the Image Export dialog will look familiar because the general layout is based on the *Print* dialog. You can either choose a scale or decide to fit to “paper” -- which is the width and height of the overall image, that you specify in pixels, inches, mm or cm. You can save a collection of settings for a particular image type by creating Presets, in the same manner that you would create one for Print settings.

## Using Direct Plotting

---

If you have an older vector output device such as a pen plotter, you can use Visual CADD’s direct plotting features to enhance control over the device. By using direct plot, you bypass the Windows print drivers and send information directly to the plotter. Direct plot allows you to use plotters that do not have a Windows driver.

Using direct plot provides control over pen mapping. When you use pen mapping, remember that many inkjet plotters use pen numbers to refer to different line types. Certain pen numbers or ranges of pen numbers may refer to lines that are not solid or that are created using a grayscale fill. If you check *All Colors to Black* in the Plot dialog, all colors will plot using the pen mapped to color 0, which is normally black.

Visual CADD increases plotting speed by using pen sorting and motion optimization. Both features take more memory, but they increase overall plot speed. Pen sorting reduces pen changes by assuring that each pen is used only once. Motion optimization improves plot performance by minimizing unnecessary pen movements and drawing from one end of the sheet to the other whenever possible.

To use direct plotting, make sure that your plotter is configured for hardware flow control.

---

**Tip** The Direct Plot routines were designed specifically for devices not supported by Windows, such as pen plotters and vinyl cutters. Inkjet plotters --which are really just large scale raster printers-- may or may not work well with Direct Plot. The Print command is the better way to go with inkjets. If you want control over line and pen management with Print, or advanced HPGL-2 features, check out the WinLINE print/plot driver at [www.winline.com](http://www.winline.com).

---

**Note** Direct plotting does not support TrueType fonts. Vector fonts will be substituted for TrueType fonts when direct plotting is used.

---

## Pen Mapping Settings

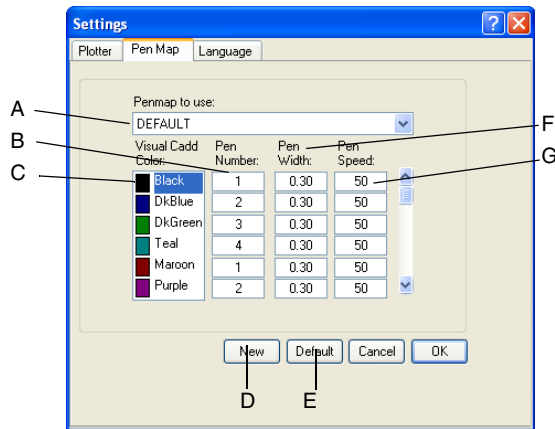

Opens when you press the [Pen Map] button on the *Plot* dialog.

**A** - list of available pen maps.

**B** - pen number assigned to a color.

**C** - the color of the corresponding pen.

**D** - creates a new pen map from current settings.

**E** - resets the map to its original settings.

**F** - adjusts the width of a pen in millimeters. Used to create solid fills.

**G** - sets speed at which the pen moves across the paper, in millimeters per second.

## Plotter Connection Settings

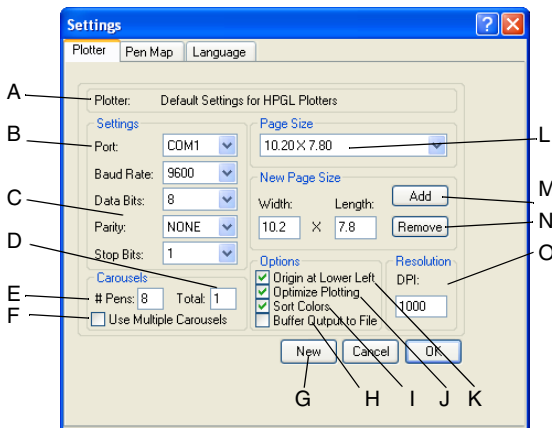

Opens when you select a plotter from the list at the top of the *Plot* dialog and then press the [Plotter Properties] button.

**A** - displays the plotter for which the current settings are listed.

**B** - specifies the communications port to which the plotter is connected.

**C** - specifies the communication settings.

**D** - sets the number of pen carousels to be used.

**E** - sets the number of pens in each carousel.

**F** - check this box if you are using more than one carousel.

**G** - creates a new plotter definition.

**H** - when checked, sends the plot file out to disk buffer before sending it to the plotter.

**I** - when checked, activates pen sorting.

**J** - when checked, activates motion optimization.

**K** - when checked, places the origin in the lower left corner of the media. When unchecked, places it in the center of the media.

**L** - selects the size of the plotter media. *Page Size* reflects the printed area on the page and not the actual sheet size.

**M** - adds a new page size to the Page Size list by using the values set in the Length and Width boxes.

**N** - deletes the current page size from the list.

**O** - specifies the maximum resolution of the plotter in dots per inch.

**Tip** Decrease overall plot time by checking Optimize Plotting and Sort Colors on the Plotter tab of the Plotter Settings dialog.

Tip: To adjust the number of seconds that Visual CADD will wait for your plotter to respond, change the time-out value on the Plot dialog.

## Making a Custom Plotter Configuration

If your plotter language is not already supported by Visual CADD, you can easily create a custom plotter definition. Use the control codes listed in your plotter's documentation to set up your plotter type.

### Plotter Language Settings

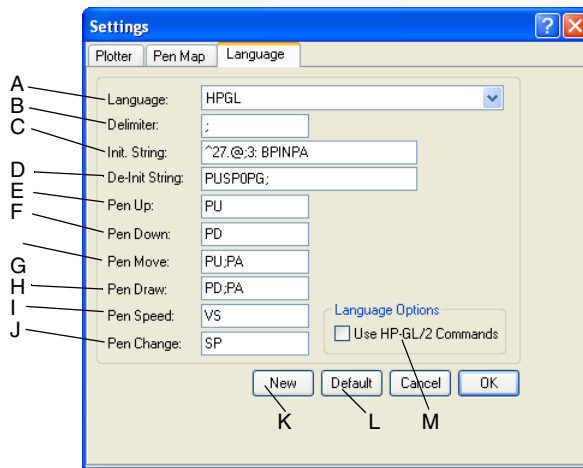

Opens when you select a plotter from the list at the top of the Plot dialog and then press the [Plotter Properties] button, then the *Language* tab.

**A** - specifies the plotter language for the current settings.

**B** - specifies the character that separates commands sent to the plotter. This field can be left blank.

**C** - describes the commands that are sent to the plotter to initialize it.

**D** - describes the commands that are sent to the plotter after a plot is completed.

**E** - specifies which characters raise the pen from the paper.

**F** - specifies which characters lower the pen to the paper.

**G** - specifies the characters that signal the plotter to move the pen from one location to another in the up position.

**H** - specifies the characters that signal the plotter to move the pen from one location to another in the down position.

**I** - specifies the characters that set the pen speed for the current pen.

**J** - specifies the characters that signal the plotter to change to a different pen.

**K** - creates a new plotter language setting.

**L** - restores the plotter language settings to the default values for an HPGL (Hewlett Packard graphics language) plotter.

**M** - enables the use of HP-GL/2. Check this box to improve the quality of arcs and circles and decrease plot time if your plotter supports the HP-GL/2 graphics language. If you check this box, you need to provide an Init String that tells your plotter to recognize HP-GL/2 commands.

---

**Tip:** To add a control character to a field, type the caret symbol (^) followed by a letter or up to three numerals. For example, type ^27 for Esc, or ^M for Enter.

---

## Increasing Printing and Plotting Speed

---

- Turn off unnecessary layers or make them non-printable. By eliminating information such as text or dimensions that you don't need in your plot, you can substantially reduce plot time. By using the same layer for all text and the same layer for all dimensions, you can easily hide these complex entities to enhance printing speed. Control the visibility of layers by selecting Layers>Layer Manager.
- Turn off the display of fills, hatches, and line widths. By printing only the boundaries of fills and hatches, and by removing line widths, substantially less information is printed and printing time is reduced. You can access these display settings by selecting Utilities>Settings>System1.
- Use simple hatch patterns. Avoid using hatch patterns that have many small elements. The smaller or more complex they are, the longer they take to plot.
- Use HP-GL/2 if you can. HP-GL/2 reduces plot time by reducing the amount of information that needs to be sent to the plotter. You can access this setting from the Plot dialog by selecting Setup>Options>Language.
- Set curve smoothness to a high value. Setting curve smoothness to a higher value causes Visual CADD to use fewer lines and create a rougher curve, but it increases plot speed. You can change Visual CADD's setting for curve smoothness on the Plot dialog. The value can range from 1–100.



# KEYBOARD SHORTCUTS & NATIVE COMMANDS

A *native command* in Visual CADD means that it runs one of the internal commands when it is invoked.

Any command can be run by typing a forward slash (/) followed by a native name on the command line (the status bar). For example to invoke the Linear Copy command, you would type **/Copy**.

In most cases however you will start a native command from a menu, a toolbar icon, or a keyboard shortcut (**CO** is the shortcut for the Copy command).

Many native commands won't work with a keyboard shortcut; they were designed to be used as part of a script, to define the settings that you draw with. Typically in a script you add a single parameter after the command. For example, **DimTextHt;4;** sets the dimension text height to 4 units high.

See Chapter 13, *Customizing Visual CADD*, and the online Help file for more information on writing and running scripts in VCADD.

To see the following list of commands sorted in three different ways, look for the topic titled *Keyboard Shortcuts and Native Commands* in the Visual CADD 6 Help file.

Quite a few of the native commands are toggles; they change the state of a setting, turning it on or off. Many of them have 2 or 3 letter shortcuts assigned; others do not. You can assign a shortcut to any toggle command on the *Custom Shortcuts* tab of the Utilities>Assign Script

dialog (make sure it isn't the same as an existing keyboard shortcut). In the following list, a toggle is marked with a star (\*).

Several of the native commands have multiple options for specific parameters that you must use; these are marked in the list with a plus sign (+). Please see the Scripting section of the Help file for a list of parameters and variables for specific commands.

| Command Description | Shortcut   | Native Command |
|---------------------|------------|----------------|
| 2-Point Arc         | <b>A2</b>  | Arc2           |
| 2-Point Circle      | <b>C2</b>  | Circle2        |
| 2-Point Rectangle   | <b>R2</b>  | Rect2          |
| 3-Point Arc         | <b>A3</b>  | Arc3           |
| 3-Point Circle      | <b>C3</b>  | Circle3        |
| 3-Point Rectangle   | <b>R3</b>  | Rect3          |
| Advanced Settings   | <b>TBA</b> | TabAdv         |
| Align               | <b>AG</b>  | Align          |
| Aligned Dimension   | <b>D3</b>  | DimAlign       |
| All Layers Edit*    | <b>AL</b>  | AllLayEdit     |
| All Layers Edit Off |            | AllLayEdOff    |
| All Layers Edit On  |            | AllLayEdOn     |
| All Layers Snap Off |            | AllLaySnOn     |
| All Layers Snap On  |            | AllLaySnOff    |
| Angular Dimension   | <b>DA</b>  | DimAng         |
| Aperture ON/OFF*    | <b>AP</b>  | Aperture       |
| Arrange Icons       |            | WinArrange     |
| Array Copy          | <b>AC</b>  | ArrayCopy      |
| Assign Script       | <b>AS</b>  | ScriptAssign   |

| <b>Command Description</b>        | <b>Shortcut</b> | <b>Native Command</b> | <b>Command Description</b>                  | <b>Shortcut</b> | <b>Native Command</b> |
|-----------------------------------|-----------------|-----------------------|---|-----------------|-----------------------|
| Attribute Attach                  | <b>TA</b>       | AttAttach             | Change linewidth in scripts +               |                 | ChangeLWidth          |
| Attribute Create                  | <b>TC</b>       | AttCreate             | Change RW linewidth in scripts +            |                 | ChangeRealW           |
| Attribute Embed                   | <b>TD</b>       | AttEmbed              | Change: Apply properties changes in scripts |                 | ChangeApply           |
| Attribute: Set Color              |                 | AtbColor              | Check Automatically for updates             |                 | UpdateSettin          |
| Attribute: Set Font               |                 | AtbFont               | Check for Updates                           |                 | GetUpdate             |
| Attribute: Display Global*        |                 | AtbGlobalDsp          | Circumscribe Regular Polygon                |                 | RPolyCrcm             |
| Attribute: Display Global Fields* |                 | AtbGibLblDsp          | Clean/Erase 0 length entities               | <b>XC</b>       | CleanData             |
| Attribute: Set Height             |                 | AtbHt                 | Clear Drawing                               | <b>DX</b>       | Clear                 |
| Attribute: Display Local*         |                 | AtbLocalDisp          | Clear Selection List                        | <b>CS</b>       | SelClear              |
| Attribute: Display Local Fields*  |                 | AtbLclLblDsp          | Close                                       | <b>FC</b>       | FileClose             |
| Attribute: Toggle Local/Global*   |                 | AtbUseLocal           | Close All                                   |                 | CloseAll              |
| AutoFillet*                       | <b>AF</b>       | AutoFillet            | Close Contour                               | <b>CC</b>       | CloseContr            |
| AutoFillet Off                    |                 | AutFilletOff          | Color Property                              | <b>CP</b>       | ColorProp             |
| AutoFillet On                     |                 | AutFilletOn           | Configuration Editor                        |                 | ConFigEdit            |
| Backward Redraw*                  | <b>BA</b>       | BackRD                | Constraints Settings                        | <b>TBC</b>      | TabCnstrnt            |
| Basepoint Point (x,y)             |                 | BasepointPt           | Continuous Bézier Curve                     | <b>BC</b>       | BezierCont            |
| Bird's-Eye View                   | <b>ZB</b>       | BirdsEye              | Continuous Line                             | <b>LC</b>       | LineCont              |
| Boolean                           | <b>BO</b>       | Boolean               | Convert Acad Polygon Width ON/OFF*          |                 | AcadPolyW             |
| Boundary Fill                     | <b>FB</b>       | FillBnd               | Copy to Clipboard                           |                 | CBCopy                |
| Boundary Hatch                    | <b>HB</b>       | HatchBnd              | Create Symbols                              | <b>YC</b>       | SymCreate             |
| Break                             | <b>BR</b>       | Break                 | Cursor Free*                                | <b>CF</b>       | CursorFree            |
| Bring Above Object                | <b>DWA</b>      | DrawAfter             | Cursor Free Off                             |                 | CursFreeOff           |
| Bring to Front                    | <b>DWF</b>      | DrawLast              | Cursor Free On                              |                 | CursFreeOn            |
| Cascade Windows                   |                 | WinCascade            | Cut to Clipboard                            |                 | CBCut                 |
| Chamfer                           | <b>CH</b>       | Chamfer               | Database Viewer                             |                 | DBView                |
| Chamfer Distance                  | <b>C0</b>       | ChamferDist           | Datum Dimension                             | <b>DU</b>       | Datum                 |
| Chamfer Distance 1                |                 | ChamDist1             | Datum Dimension Off                         |                 | DatumOff              |
| Chamfer Distance 2                |                 | ChamDist2             | Datum X                                     |                 | DatumX                |
| Change                            | <b>CG</b>       | Change                | Datum XY                                    |                 | DatumXY               |
| Change layer in scripts +         |                 | ChangeLayer           | Datum Y                                     |                 | Datum Y               |
| Change color in scripts +         |                 | ChangeColor           |   |                 |                       |
| Change linetype in scripts +      |                 | ChangeLType           |   |                 |                       |

| <b>Command Description</b>          | <b>Shortcut</b> | <b>Native Command</b> |
|-------------------------------------|-----------------|-----------------------|
| Dialog OK button                    |                 | DlgOk                 |
| Diameter Circle                     | <b>CD</b>       | CircDiam              |
| Diameter Dimension                  | <b>DD</b>       | DimDia                |
| Digitizer Mode*                     | <b>GM</b>       | DigMode               |
| Digitizer Scale                     | <b>GZ</b>       | DigScale              |
| Dim Mode: Cumulative                | <b>D6</b>       | DimCumul              |
| Dim Mode: Partitioned               | <b>D7</b>       | DimPart               |
| Dim Mode: Single                    | <b>D5</b>       | DimSingle             |
| Dim Text Alignment                  | <b>DMG</b>      | DimTextAlign          |
| Dimension Arrow Settings            | <b>DMA</b>      | DimArrowSet           |
| Dimension Arrow Type +              |                 | DimArrowType          |
| Dimension Arrow Size                |                 | DimArrowSize          |
| Dimension Arrow Angle               |                 | DimArrowAng           |
| Dimension Arrow Flip*               |                 | DimArrowFlip          |
| Dimension at Angle                  | <b>D4</b>       | DimAtAngle            |
| Dimension Angle Variable            |                 | DimAngle              |
| Dimension Display Settings          | <b>DMD</b>      | DimDispSet            |
| Dimension Edit                      |                 | DimCh                 |
| Dimension Extension Offset Distance |                 | DimExtOffset          |
| Dimension Extension Above Distance  |                 | DimExtAbove           |
| Dimension Extension Below Distance  |                 | DimExtBelow           |
| Dimension Flip Distance Left        |                 | DimFlipLeft           |
| Dimension Flip Distance Right       |                 | DimFlipRight          |
| Dimension Flip Reference            |                 | DimRefFlip            |
| Dimension Extension Settings        | <b>DMX</b>      | DimExtSet             |
| Dimension Horizontal Text ON/OFF    | <b>D8</b>       | DimHorzTxt            |
| Dimension In-Line Text ON/OFF       | <b>D9</b>       | DimInlineTxt          |
| Dimension Leader Settings           | <b>DME</b>      | DimLeadSet            |

| <b>Command Description</b>         | <b>Shortcut</b> | <b>Native Command</b> |
|------------------------------------|-----------------|-----------------------|
| Dimension Line Display*            |                 | DimLineShow           |
| Dimension Line Settings            | <b>DML</b>      | DimLineSet            |
| Dimension Left Arrow Color         |                 | DimLtArColor          |
| Dimension Left Arrow Display*      |                 | DimLtArShow           |
| Dimension Left Arrow Type          |                 | DimLtArType           |
| Dimension Left Arrow Width         |                 | DimLtArWidth          |
| Dimension Left Extension Color     |                 | DimLtExColor          |
| Dim. Left Extension Display*       |                 | DimLtExShow           |
| Dim. Left Extension Type           |                 | DimLtExType           |
| Dim. Left Extension Width          |                 | DimLtExType           |
| Dimension Line Color               |                 | DimLineColor          |
| Dimension Line Type                |                 | DimLineType           |
| Dimension Line Width               |                 | DimLineWidth          |
| Dimension Move Line                |                 | DimMoveLine           |
| Dimension Move Arc                 |                 | DimMoveArc            |
| Dimension Right Arrow Color        |                 | DimRtArColor          |
| Dimension Right Arrow Display*     |                 | DimRtArShow           |
| Dimension Right Arrow Type         |                 | DimRtArType           |
| Dimension Right Arrow Width        |                 | DimRtArWidth          |
| Dim. Right Extension Color         |                 | DimRtExColor          |
| Dimension Right Extension Display* |                 | DimRtExShow           |
| Dim. Right Extension Type          |                 | DimRtExType           |
| Dim. Right Extension Width         |                 | DimRtExWidth          |
| Dimension Scale                    | <b>DMZ</b>      | DimScaleSet           |
| Dimension Stretch*                 |                 | DimStretch            |

| <b>Command Description</b>         | <b>Shortcut</b> | <b>Native Command</b> |
|------------------------------------|-----------------|-----------------------|
| Dimension String Settings          | <b>DMS</b>      | DimStrSet             |
| Dimension Settings dialog          | <b>TBD</b>      | TabDim                |
| Dimension Text Above               |                 | DimTextAbove          |
| Dimension Text Alternate Rotation* |                 | DimTextAltRot         |
| Dimension Text Aspect              |                 | DimTextAsp            |
| Dimension Text Bold*               |                 | DimTextBold           |
| Dimension Text Centered*           |                 | DimTextCent           |
| Dimension Text Character Spacing   |                 | DimTextChSp           |
| Dimension Text Color               |                 | DimTextColor          |
| Dimension Text Fill*               |                 | DimTextFill           |
| Dimension Text Font                |                 | DimTextFont           |
| Dimension Text Height              |                 | DimTextHt             |
| Dimension Text Inline              |                 | DimTextInLn           |
| Dimension Text Italic*             |                 | DimTextItal           |
| Dimension Text Line Spacing        |                 | DimTextLnSp           |
| Dimension Text Linetype            |                 | DimTextType           |
| Dimension Text LineWidth           |                 | DimTextWidth          |
| Dimension Text Monospace*          |                 | DimTextMono           |
| Dimension Text Move                |                 | DimMoveTxt            |
| Dimension Text Overwrite*          |                 | DimTextOvwrt          |
| Dimension Text Overwrite String    |                 | DimTextOvStr          |
| Dimension Text Prefix*             |                 | DimTextPrefx          |
| Dimension Text Prefix String       |                 | DimTextPreSt          |
| Dimension Text Scale               |                 | DimTextScale          |
| Dimension Text Settings            | <b>DMT</b>      | DimTextSet            |
| Dimension Text Display*            |                 | DimTextShow           |
| Dimension Text Slant               |                 | DimTextSlant          |
| Dimension Text Slide               |                 | DimSlideTxt           |
| Dimension Text Suffix*             |                 | DimTextSuffx          |

| <b>Command Description</b>     | <b>Shortcut</b> | <b>Native Command</b> |
|--------------------------------|-----------------|-----------------------|
| Dimension Text Suffix String   |                 | DimTextSufSt          |
| Dimension Text Settings dialog | <b>TBX</b>      | TabDimText            |
| Dim Text Tolerance+            |                 | DimTextTol            |
| Dimension Text Tolerance Lower |                 | DimTextTolLo          |
| Dimension Text Tolerance Upper |                 | DimTextTolUp          |
| Dimension Text Underline*      |                 | DimTextUnder          |
| Dimension Text Vertical+       |                 | DimTextVert           |
| Dimension Tolerance Settings   | <b>DMO</b>      | DimTolSet             |
| Dimension Use Layer*           |                 | DimUseLayer           |
| Dimension Use Layer Variable   |                 | DimLayer              |
| Dimension Wizard               | <b>WID</b>      | WIZDIM                |
| Dimension: Proximity Fixed*    | <b>PF</b>       | ProxFixed             |
| Display Layer                  | <b>YD</b>       | LayDisplay            |
| Divide speedbar                | <b>IV</b>       | Divide                |
| Divide # of segments           |                 | NumDivide             |
| Divide Break into segments*    |                 | DivBreak              |
| DLL Command Line variable      |                 | DllCmdLine            |
| Dll Function Name variable     |                 | DllFunName            |
| Dll Name variable              |                 | DllName               |
| Dll Run                        |                 | DllRun                |
| Dll Run Nested                 |                 | DllRunNested          |
| Double line                    | <b>LD</b>       | LineDbl               |
| Double Line Fill Off           |                 | SolidOff              |
| Double Line Fill On            |                 | SolidOn               |
| Double Line Offset 1           |                 | WallWidth1            |
| Double Line Offset 2           |                 | WallWidth2            |
| Double Line Settings           | <b>DB</b>       | DBSet                 |

| <b>Command Description</b> | <b>Shortcut</b> | <b>Native Command</b> | <b>Command Description</b>                             | <b>Shortcut</b> | <b>Native Command</b> |
|----------------------------|-----------------|-----------------------|--|-----------------|-----------------------|
| Drawing Align              | <b>GA</b>       | DigAlign              | Filter Linetype  |                 | FitLnType             |
| Drawing Properties         | <b>WIP</b>      | WIZPROP               | Filter Linewidth                                       |                 | FitLnWidth            |
| Drawing: Change Properties | <b>DG</b>       | DWGCHANGE             | Filter Name for Symbol, Text, Hatch & RefFrame Entity+ |                 | FitName               |
| Drawing: Change Scale      | <b>DZ</b>       | DWGSCALE              | Filter Active ON/OFF*                                  |                 | FitActive             |
| Drawing: Rotate            | <b>DT</b>       | DWGROTATE             | Filter Reset to "All"                                  |                 | FitReset              |
| Drawing Wizard             | <b>WIR</b>      | WIZDRAW               | Fit Scale  | <b>FT</b>       | FitScale              |
| Edit                       | <b>ED</b>       | Edit                  | Fixed Offset Off                                       |                 | OffsetFixOff          |
| Edit Dimension             | <b>DE</b>       | DimEdit               | Fixed Offset On  |                 | OffsetFixOn           |
| Ellipse                    | <b>EP</b>       | Ellipse               | Flip Arrow*  | <b>AR</b>       | ArrowFlip             |
| Elliptical Arc             | <b>EA</b>       | EllArc                | Font Converter   |                 | FontConv              |
| Erase                      | <b>ER</b>       | Erase                 | Font Manager dialog                                    | <b>TBF</b>      | TabFonts              |
| Erase Last                 | <b>EL</b>       | EraseLast             | General Settings dialog                                | <b>TBG</b>      | TabGeneral            |
| Exename Variable           |                 | ExeName               | Grid Display*  | <b>GR</b>       | GridDisp              |
| Exit                       | <b>FX</b>       | FileExit              | Grid Origin  | <b>GO</b>       | GridOrg               |
| Explode                    | <b>EX</b>       | Explode               | Grid Size (x,y)  | <b>GS</b>       | GridSize              |
| Explode Continuous Lines*  | <b>CX</b>       | ContLineEx            | Grid Size X  |                 | GridSizeX             |
| Explode Symbols            | <b>YX</b>       | SymExplode            | Grid Size Y  |                 | GridSizeY             |
| Export to BMP, TIFF etc... | <b>XPI</b>      | ExportImage           | Group: Create  | <b>GP</b>       | Group                 |
| Export to PDF              | <b>XPP</b>      | ExportPDF             | Group: Ungroup   | <b>GU</b>       | Ungroup               |
| Export to CAD files        | <b>XPC</b>      | ExportCAD             | Group: Join Group                                      | <b>GJ</b>       | JoinGroup             |
| Export to XML              | <b>XPX</b>      | ExportXML             | Group: Leave Group                                     | <b>GL</b>       | LeaveGroup            |
| Extend Multiple            | <b>XM</b>       | MExtend               | Hatch Change   | <b>HC</b>       | HatchCh               |
| Extend Single              | <b>XT</b>       | Extend                | Hatch Color  |                 | HatchColor            |
| File: Compress data        |                 | FileCompress          | Hatch Name   |                 | HatchName             |
| File: Password protect     |                 | FileProtect           | Hatch Rotation   |                 | HatchRot              |
| File Run                   | <b>FU</b>       | FileRun               | Hatch Scale  |                 | HatchScale            |
| Fill Color                 |                 | FillColor             | Hatch Selected   | <b>HS</b>       | HatchSel              |
| Fill Selected              | <b>FS</b>       | FillSel               | Hatch Settings   | <b>HT</b>       | HatchSet              |
| Fillet                     | <b>FI</b>       | Fillet                | Hatch/Fill Show Boundary*                              |                 | HatchDrawBnd          |
| Fillet Radius              | <b>FR</b>       | FilletRad             | Hatch/Fill Tab   | <b>TBH</b>      | TabHatch              |
| Fillet Radius Variable     |                 | FilletRVar            | Help on Command  |                 | HelpOnCmd             |
| Filter Entity Type+        |                 | FitEntity             | Help, About  |                 | HelpAbout             |
| Filter Layer               |                 | FitLayer              | Help, Index  |                 | HelpIndex             |
| Filter Color               |                 | FitColor              |  |                 |                       |

| <b>Command Description</b>                      | <b>Shortcut</b> | <b>Native Command</b> | <b>Command Description</b>           | <b>Shortcut</b> | <b>Native Command</b> |
|---|-----------------|-----------------------|--------------------------------------|-----------------|-----------------------|
| Help, send e-mail                               |                 | HelpSupport           | Layer Property                       | <b>CL</b>       | LayerProp             |
| Help, TriTools website                          |                 | HelpWebsite           | Layer: Select one layer              |                 | LaySelect1            |
| Hidden Layer Message*                           | <b>HM</b>       | HidLayerMsg           | Layer: Display layer(s) via a script |                 | DispLayers            |
| Hide Layer                                      | <b>YH</b>       | LayHide               | Layer Lock                           | <b>YK</b>       | LayLock               |
| Horizontal Dimension                            | <b>D1</b>       | DimHorz               | Layer Unlock                         | <b>YU</b>       | LayUnlock             |
| Image, placing                                  | <b>IG</b>       | PlaceImage            | Layer: lock layer via script         |                 | LockLayers            |
| Image, editing existing                         |                 | ImageEdit             | Layer: unlock layer via a script     |                 | UnlockLayers          |
| Import CAD drawings                             | <b>XIC</b>      | ImportCAD             | Leader                               | <b>LE</b>       | Leader                |
| Import XML files                                | <b>XIX</b>      | ImportXML             | Leader Settings dialog               | <b>TBL</b>      | TabLeader             |
| Import/Export DWG settings dialog               |                 | DWGImpExp             | Leader Text dialog                   | <b>TBE</b>      | TabLdrText            |
| Import/Export GCD dialog                        |                 | GCDImpExp             | Leader Arrow Angle                   |                 | LdrArrowAng           |
| Incremental Snap*                               | <b>IN</b>       | IncSnap               | Leader Arrow Size                    |                 | LdrArrowSize          |
| Incremental Snap Off                            |                 | IncSnapOff            | Leader Arrow Type+                   |                 | LdrArrowType          |
| Incremental Snap On                             |                 | IncSnapOn             | Leader Offset                        |                 | LdrOffset             |
| Incremental Snap Size                           |                 | IncSnapSize           | Leader Shoulder                      |                 | LdrShoulder           |
| Inscribe Regular Polygon                        |                 | RPolyIn               | Leader Text Aspect                   |                 | LdrTextAsp            |
| Intersection Trim                               | <b>IT</b>       | IntTrim               | Leader Text Bold*                    |                 | LdrTextBold           |
| Invert Selection List                           | <b>IS</b>       | SelInvert             | Leader Text Character Spacing        |                 | LdrTextChSp           |
| Irregular Polygon                               | <b>IP</b>       | IPoly                 | Leader Text Fill*                    |                 | LdrTextFill           |
| ISO Left Plane                                  | <b>IL</b>       | IsoLeft               | Leader Text Font                     |                 | LdrTextFont           |
| ISO Mode ON/OFF*                                | <b>IM</b>       | IsoMode               | Leader Text Height                   |                 | LdrTextHt             |
| ISO Right Plane                                 | <b>IR</b>       | IsoRight              | Leader Text Italic*                  |                 | LdrTextItal           |
| ISO Top Plane                                   | <b>IO</b>       | IsoTop                | Leader Text Line Spacing             |                 | LdrTextLnSp           |
| Join Objects                                    | <b>JO</b>       | Join                  | Leader Text Monospace*               |                 | LdrTextMono           |
| Last Symbol                                     | <b>YL</b>       | SymLast               | Leader Text Text Slant               |                 | LdrTextSlant          |
| Layer Group dialog                              | <b>LG</b>       | LayerGroup            | Leader Text Underline*               |                 | LdrTextUnder          |
| Layer Group combo box                           |                 | LayerGroupCB          | Linear Copy                          | <b>CO</b>       | Copy                  |
| Layer Group: Apply a Group(s) via a script      |                 | GroupApply            | Linear Dimension                     | <b>DL</b>       | DimLin                |
| Layer Group: Use Layer Group properties ON/OFF* | <b>GG</b>       | GroupProp             | Line Scale speedbar                  | <b>LZ</b>       | LineScale             |
| Layer Manager dialog                            | <b>MGL</b>      | LayMgr                | Linetype Property                    | <b>TP</b>       | TypeProp              |
| Layer: Hide layer(s) via a script               |                 | HideLayers            | Linetype Scale Device                |                 | LTScaleD              |
| Layer Properties Dialog                         | <b>PY</b>       | LayPropDlg            | Linetype Scale World                 |                 | LTScaleW              |
|   |                 |                       | Linewidth Property                   | <b>WP</b>       | WidthProp             |

| <b>Command Description</b>    | <b>Shortcut</b> | <b>Native Command</b> |
|-------------------------------|-----------------|-----------------------|
| Load ASCII Text               | <b>LA</b>       | LoadAscii             |
| Load Attribute                | <b>TO</b>       | AttOpen               |
| Load Line Type                |                 | LoadLnt               |
| Load Macro                    |                 | AutoMacro             |
| Load Menu                     | <b>LM</b>       | LoadMenu              |
| Load Style                    | <b>TY</b>       | LoadStyle             |
| Load Symbol                   | <b>YO</b>       | SymOpen               |
| Main toolbar toggle*          |                 | MainsBar              |
| Macros: Load Macro dialog     |                 | AutoMacro             |
| Manual Entry: Absolute        | <b>MO</b>       | Absolute              |
| Manual Entry: BasePoint       | <b>MB</b>       | Basepoint             |
| Manual Entry: Relative        | <b>MR</b>       | Relative              |
| Match Entity                  | <b>ME</b>       | MatchEnt              |
| Match Tool                    | <b>MT</b>       | MatchTool             |
| Measure Area                  | <b>MA</b>       | MeasArea              |
| Measure Distance              | <b>MD</b>       | MeasDist              |
| Merge                         | <b>FM</b>       | FileMerge             |
| Midline tool                  | <b>ML</b>       | Midline               |
| Mirror                        | <b>MI</b>       | Mirror                |
| Move                          | <b>MV</b>       | Move                  |
| Move Dimension Text           |                 | DimMoveTxt            |
| Move Point                    | <b>MP</b>       | MovePt                |
| List of recently opened files |                 | MRUFileList           |
| MultiBreak                    | <b>BM</b>       | MultiBreak            |
| MultiLine command             | <b>MN</b>       | MultiLine             |
| MultiLine Settings            | <b>MS</b>       | MultiSet              |
| MultiLine Style               |                 | MulLineStyle          |
| MultiLine settings Apply      |                 | MulSetApply           |
| MultiLine set color           |                 | MulSetColor           |
| MultiLine set get             |                 | MulSetGet             |
| MultiLine set layer           |                 | MulSetLayer           |
| MultiLine set linetype        |                 | MulSetLType           |
| MultiLine set linewidth       |                 | MulSetLWidth          |
| MultiLine set offset          |                 | MulSetOffset          |

| <b>Command Description</b>              | <b>Shortcut</b> | <b>Native Command</b> |
|---|-----------------|-----------------------|
| MultiLine set RW width                  |                 | MulSetRealw           |
| MultiLine set reset                     |                 | MulSetReset           |
| MultiLine set use                       |                 | MulSetUse             |
| Multiple Dimensions                     | <b>MM</b>       | DimSelected           |
| Multiple Copy                           | <b>MC</b>       | MultiCopy             |
| Name File                               |                 | FileName              |
| Name View                               | <b>NV</b>       | NameView              |
| New                                     | <b>FN</b>       | FileNew               |
| New Symbol Handle                       | <b>NH</b>       | NewHandle             |
| New View                                | <b>VW</b>       | NewView               |
| Number of Copies                        |                 | NumCopies             |
| Number of Rows                          |                 | NumRows               |
| Numeric Settings dialog                 | <b>TBN</b>      | TabNumeric            |
| Numeric Dim. Decimal+                   |                 | DimDecimal            |
| Numeric Dim. Fractional+                |                 | DimFraction           |
| Numeric Dim. Angle Format+              |                 | DimAngForm            |
| Numeric Dim. Leading Zeros*             |                 | DimLeadZero           |
| Numeric Dim. Show Dash*                 |                 | ShowDash              |
| Numeric Dim. Show Units*                |                 | DimUnits              |
| Numeric Dim. Show Single Unit Fraction* |                 | DimSUfrac             |
| Numeric Dim. Show Secondary Units*      |                 | DimSecond             |
| Numeric Dim. Unit Format+               |                 | DimDistForm           |
| Numeric Dim. Secondary Unit+            |                 | DimSecForm            |
| Numeric Display Decimal+                |                 | DispDecimal           |
| Numeric Display Fractional+             |                 | DispFraction          |
| Numeric Display Angle Format+           |                 | DispAngForm           |
| Numeric Display Ldng. Zero*             |                 | DispLeadZero          |

| <b>Command Description</b> | <b>Shortcut</b> | <b>Native Command</b> | <b>Command Description</b> | <b>Shortcut</b> | <b>Native Command</b> |
|----------------------------|-----------------|-----------------------|----------------------------|-----------------|-----------------------|
| Numeric Display Units*     |                 | DispUnits             | Path Settings dialog       | <b>TBP</b>      | TabPath               |
| Object Information         | <b>OI</b>       | ObjInfo               | Path: DWG                  |                 | DWGPath               |
| Object: Change Properties  | <b>OG</b>       | OBJCHANGE             | Path: DXF                  |                 | DXFPath               |
| Object: Copy               | <b>OC</b>       | OBJCOPY               | Path: GCD                  |                 | GCDPath               |
| Object: Move               | <b>OM</b>       | OBJMOVE               | Path: MNU                  |                 | MNUPath               |
| Offset                     | <b>OF</b>       | Offset                | Path: STY                  |                 | STYPath               |
| Offset Distance            |                 | OffsetDist            | Path: System               |                 | SYSPath               |
| OLE Class                  |                 | OleClass              | Path: VCD                  |                 | VCDPath               |
| OLE Class Name             |                 | OleClassName          | Path: VCF                  |                 | VCFPath               |
| OLE Command Line           |                 | OleCmdLine            | Path: VCS                  |                 | VCSPath               |
| OLE DII Name               |                 | OleDIIName            | Pen Up                     | <b>PU</b>       | Penup                 |
| OLE Function Name          |                 | OleFunName            | Place Symbol               | <b>YP</b>       | SymPlace              |
| OLE Method                 |                 | OleMethod             | Plot                       | <b>PL</b>       | FilePlot              |
| OLE Insert Object          |                 | InsertOLEObj          | Point                      | <b>PO</b>       | Point                 |
| OLE Edit/Open              |                 | OLEVerbs              | Polygon Merge              | <b>PM</b>       | MergePoly             |
| OLE Link                   |                 | EditLinks             | Polygon Split              | <b>PG</b>       | SplitPoly             |
| Open                       | <b>FO</b>       | FileOpen              | Preview Fillet Off         |                 | FilletPrvOff          |
| Ordinate Dimension         | <b>DO</b>       | DimOrd                | Preview Fillet On          |                 | FilletPrvOn           |
| Ortho Advanced speedbar    | <b>OV</b>       | OrthoAdv              | Print                      | <b>PR</b>       | FilePrint             |
| Ortho Advanced Type+       |                 | OrthoAdvType          | Print: Add Preset          |                 | PrtAddPreset          |
| Ortho Advanced Step        |                 | OrthoAdvStep          | Print: Delete Preset       |                 | PrtDelPreset          |
| Ortho Advanced Increment   |                 | OrthoAdvInc           | Print: set Current Preset  |                 | PrtCurPreset          |
| Ortho Advanced One Angle   |                 | OrthoAdvOne           | Print: set Printer+        |                 | PrtDevice             |
| Ortho Angle Variable       |                 | OrAngVar              | Print: Page Width          |                 | PrtPgWidth            |
| Ortho Mode*                | <b>OR</b>       | OrthoMode             | Print: Page Height         |                 | PrtPgHeight           |
| Ortho Off                  |                 | OrthoOff              | Print: Left Margin         |                 | PrtMargLeft           |
| Ortho On                   |                 | OrthoOn               | Print: Bottom Margin       |                 | PrtMargBot            |
| Ortho Settings speedbar    | <b>OA</b>       | OrthoSet              | Print: Right Margin        |                 | PrtMargRight          |
| Pack Data                  | <b>PD</b>       | PackData              | Print: Top Margin          |                 | PrtMargTop            |
| Pan                        | <b>PA</b>       | ZmPan                 | Print: Scale               |                 | PrtScale              |
| Paste from Clipboard       |                 | CBPaste               | Print: Origin (x,y)        |                 | PrtOrigin             |
| Paste OLE into drawing     |                 | PasteObject           | Print: Type of View        |                 | PrtViewType           |
|                            |                 |                       | Print: Landscape*          |                 | PrtLandscape          |
|                            |                 |                       | Print: Number of Copies    |                 | PrtNumCopies          |
|                            |                 |                       | Print: Rotation Angle      |                 | PrtRotAngle           |

| <b>Command Description</b>        | <b>Shortcut</b> | <b>Native Command</b> |
|-----------------------------------|-----------------|-----------------------|
| Print: Metric*                    |                 | PrtMetric             |
| Print: Fast Draw*                 |                 | PrtFastDraw           |
| Print: Selected*                  |                 | PrtSelected           |
| Print: Print to file*             |                 | PrtToFile             |
| Print: Date Stamp*                |                 | PrtDateStamp          |
| Print: Stamp Font                 |                 | PrtStampFont          |
| Print: Stamp Font Size            |                 | PrtStampSize          |
| Print: Stamp Date Format          |                 | PrtStampFor           |
| Print: Stamp Location             |                 | PrtStampLoc           |
| Print: All Colors to Black*       |                 | PrtAllBlack           |
| Print: LW 0 has Width*            |                 | PrtW0HasWid           |
| Print: BaseLine Width             |                 | PrtLineWidth          |
| Print: Move Page                  |                 | PrtMovePage           |
| Print: Paper Size                 |                 | PrtPaperSize          |
| Print: Preview*                   |                 | PrtPreview            |
| Print: Paper Length               |                 | PrtLen                |
| Print: Paper Width                |                 | PrtWid                |
| Print: Centered*                  |                 | PrtCenter             |
| Print: Print without dialog       |                 | PrtNoDlg              |
| Properties Button                 | <b>PP</b>       | Properties            |
| Purge Line Type                   |                 | PurgeLnt              |
| # of Radial Copies                |                 | RadCopies             |
| Radial Copy                       | <b>RC</b>       | RadCopy               |
| Radial Dimension                  | <b>DR</b>       | DimRad                |
| Radial Span Angle                 |                 | RadSpanAngle          |
| Redo                              | <b>RE</b>       | Redo                  |
| Redraw                            | <b>RD</b>       | Regen                 |
| Redraw All Views                  |                 | RegenAllView          |
| Redraw Window                     | <b>RW</b>       | RegenArea             |
| Reference Frame: Create           | <b>RFC</b>      | RFCreat               |
| Reference Frame: Display Boundary |                 | RFDispBnd             |
| Reference Frame: Place            | <b>RFP</b>      | RFPlace               |
| Reference Frame: Transparent      |                 | RFTrans               |
| Registry Editor                   |                 | RegEdit               |

| <b>Command Description</b>        | <b>Shortcut</b> | <b>Native Command</b> |
|-----------------------------------|-----------------|-----------------------|
| Regular Polygon - Number of Sides |                 | RPolyNSides           |
| Regular Polygon-Center            | <b>PC</b>       | RPolyCen              |
| Regular Polygon-Circumscribed     |                 | RPolyCrcm             |
| Regular Polygon-Side              | <b>PS</b>       | RPolySide             |
| Reset                             |                 | Reset                 |
| Rotate                            | <b>RO</b>       | Rotate                |
| Run "EXENAME"                     | <b>FU</b>       | WinExec               |
| Run Windows .exe file             | <b>FU</b>       | WinExec               |
| Running Snap Mode ON/OFF          | <b>RS</b>       | SnRun                 |
| Running Snaps dialog              | <b>RN</b>       | SnType                |
| Running Snap Endpt*               | <b>XSC</b>      | RSEndPoint            |
| Running Snap Object*              | <b>XSO</b>      | RSObject              |
| Running Snap Midpt*               | <b>XSM</b>      | RSMidPoint            |
| Running Snap Intersection*        | <b>XSI</b>      | RSIntersec            |
| Running Snap Perpendicular*       | <b>XSP</b>      | RSPerpend             |
| Running Snap Tangent*             | <b>XST</b>      | RSTangent             |
| Running Snap Percent*             | <b>XSR</b>      | RSPercent             |
| Running Snap Quadrant*            | <b>XSQ</b>      | RSQuadrant            |
| Running Snap Center*              | <b>XSN</b>      | RSCenter              |
| Running Snap All*                 | <b>XSA</b>      | RSAll                 |
| Save                              | <b>DS</b>       | FileSave              |
| Save As                           | <b>FA</b>       | FileSaveAs            |
| Save All                          | <b>FL</b>       | FileSaveAll           |
| Save Attribute                    | <b>TS</b>       | AttSave               |
| Save Environment                  | <b>EN</b>       | SaveEnv               |
| Save Style                        | <b>TV</b>       | SaveStyle             |
| Save Symbol                       | <b>YS</b>       | SymSave               |
| Scale                             | <b>SZ</b>       | Scale                 |
| Scrollbar On/Off*                 |                 | ScrollBar             |
| Seed Fill                         | <b>FD</b>       | SeedFill              |
| Seed Hatch                        | <b>HD</b>       | SeedHatch             |
| Select Adjoining                  | <b>SJ</b>       | SelAdj                |

| <b>Command Description</b>      | <b>Shortcut</b> | <b>Native Command</b> | <b>Command Description</b>           | <b>Shortcut</b> | <b>Native Command</b> |
|---------------------------------|-----------------|-----------------------|--------------------------------------|-----------------|-----------------------|
| Select All                      | <b>SA</b>       | SelAll                | Snap Center                          | <b>SN</b>       | SnCenter              |
| Select Crossing                 | <b>SX</b>       | SelCross              | Snap Closest Point                   | <b>SC</b>       | SnClosestPt           |
| Select Last                     | <b>SL</b>       | SelLast               | Snap Grid                            | <b>SG</b>       | SnapGrid              |
| Select Last Object              | <b>SO</b>       | SelLastObj            | Snap Intersection                    | <b>SI</b>       | SnIntersect           |
| Select Layer                    | <b>SY</b>       | SelLay                | Snap Last Point                      | <b>LP</b>       | SnLastPt              |
| Select Modified                 | <b>SU</b>       | SelMod                | Snap Layer                           | <b>NL</b>       | SnapLayer             |
| Select Object                   | <b>SB</b>       | SelObj                | Snap MidPoint                        | <b>SM</b>       | SnMidPt               |
| Select Window                   | <b>SW</b>       | SelWin                | Snap Near Point                      | <b>NP</b>       | SnNearPt              |
| Selection Filter                | <b>SF</b>       | Filter                | Snap Object                          | <b>SO</b>       | SnObject              |
| Selection Highlight On/<br>Off* | <b>HI</b>       | Hilite                | Snap Parallel                        | <b>LL</b>       | SnPara                |
| Selection Set                   |                 | SelSet                | Snap Percentage                      | <b>SR</b>       | SnPercent             |
| Selection Speed Bar             | <b>S1</b>       | SelRibalog            | Snap Percentage Value                |                 | PercSnapVal           |
| Selection Tool                  | <b>SE</b>       | Selection             | Snap Perpendicular                   | <b>SP</b>       | SnPerp                |
| Send                            | <b>SD</b>       | FileSend              | Snap Preview (Running<br>Snaps)*     | <b>RV</b>       | SnPrev                |
| Send Behind Object              | <b>DWH</b>      | DrawBefore            | Snap Quadrant                        | <b>SQ</b>       | SnQuad                |
| Send to Back                    | <b>DWB</b>      | DrawFirst             | Snap Tangent                         | <b>ST</b>       | SnTangent             |
| Set BasePoint                   | <b>BP</b>       | SetBasePt             | Snap to Curve Tangent<br>Pts*        | <b>DV</b>       | CurveTanPts           |
| Set Configuration Editor        |                 | SetCfgEdit            | Spellchecker                         | <b>SK</b>       | SpellCheck            |
| Set Current Color               |                 | SetColor              | Spellcheck Options                   |                 | SpellOpt              |
| Set Current Layer               |                 | SetLayer              | Spline Curve                         | <b>CV</b>       | Curve                 |
| Set Current Linetype            |                 | SetType               | Status Bar toggle*                   |                 | StatusBar             |
| Set Current Linewidth           |                 | SetWidth              | Stretch                              | <b>SS</b>       | Stretch               |
| Set Current RW Linewidth        |                 | SetRealWidth          | Symbol Auto Explode on<br>Placement* |                 | SymAutoExp            |
| Set Rotation Angle              |                 | SetAngle              | Symbol Autoexplode to<br>layer+      |                 | SymExplodeTo          |
| Set Scale X                     |                 | SetScaleX             | Symbol Break                         | <b>YB</b>       | SymbolBreak           |
| Set Scale X & Y                 |                 | SetScale              | Symbol Count                         |                 | SymCount              |
| Set Scale Y                     |                 | SetScaleY             | Symbol Explode                       | <b>YX</b>       | SymExp                |
| Side Toolbar toggle*            |                 | ToolBar               | Symbol Manager                       | <b>MGY</b>      | SymMgr                |
| Single Bézier Curve             | <b>BS</b>       | BezierSingle          | Symbol Name                          |                 | SymName               |
| Single Copy                     | <b>C1</b>       | CopySingle            | Symbol Remove                        | <b>YV</b>       | SymRemove             |
| Single line                     | <b>LS</b>       | LineSingle            | Symbol Replace                       | <b>YR</b>       | SymReplace            |
| Skew                            | <b>KW</b>       | Skew                  | Symbol Rotation                      |                 | SymRot                |
| Skew: angle in scripts          |                 | SkewAngle             |                                      |                 |                       |
| Snap between 2 Points           | <b>S2</b>       | SnMid2Pts             |                                      |                 |                       |

| <b>Command Description</b>      | <b>Shortcut</b> | <b>Native Command</b> |
|---------------------------------|-----------------|-----------------------|
| Symbol Scale X & Y              |                 | SymScale              |
| Symbol Scale X                  |                 | SymScX                |
| Symbol Scale Y                  |                 | SymScY                |
| Symbol Settings dialog          | <b>TBY</b>      | TabSymbols            |
| Symbol Snap*                    | <b>YN</b>       | SymSnap               |
| Symbol Snap Off                 |                 | SymSnapOff            |
| Symbol Snap On                  |                 | SymSnapOn             |
| Symbol UnBreak                  | <b>YU</b>       | SymUnBreak            |
| System1 Settings dialog         | <b>TBS</b>      | TabSystem             |
| Sys1: Arrows World/Screen*      |                 | ArrowWorld            |
| Sys1: Arrow Key World Inc.      |                 | AroWrldStep           |
| Sys1: Arrow Key Screen Inc.     |                 | AroScrnStep           |
| Sys1: Background Color          |                 | BackColor             |
| Sys1: Cursor Color              |                 | CursColor             |
| Sys1: Cursor Size on-screen     |                 | CursorSize            |
| Sys1: Default Tool+             |                 | DefTool               |
| Sys1: Display Construction Pts* | <b>DC</b>       | ConstPts              |
| Sys1: Display Handle Pts*       | <b>DH</b>       | HandlePts             |
| Sys1: Display Line Types*       | <b>LT</b>       | ShowLnType            |
| Sys1: Display Line Widths*      | <b>LW</b>       | ShowLnWidth           |
| Sys1: Display Fills*            | <b>TF</b>       | ShowFill              |
| Sys1: Display Hatches*          | <b>TH</b>       | ShowHatch             |
| Sys1: Display Points*           | <b>TI</b>       | ShowPoint             |
| Sys1: Quick Search*             | <b>QS</b>       | QSearch               |
| Sys1: Rubberband Color          |                 | RubColor              |
| Sys1: Search Tolerance          |                 | SearchTol             |
| Sys1: Selection Color           |                 | SelColor              |
| Sys1: Show Scrollbars*          |                 | ScrollBar             |
| Sys1: Show Drag*                |                 | ShowDrag              |
| Sys1: Zoom Ask Center Point*    |                 | AskCenter             |

| <b>Command Description</b> | <b>Shortcut</b> | <b>Native Command</b> |
|----------------------------|-----------------|-----------------------|
| Sys1: Zoom Factor In/Out   |                 | ZoomFactor            |
| System2 Settings dialog    | <b>TB2</b>      | TabSys2               |
| Sys2: Save Env. on Exit*   |                 | EnvSaveExit           |
| Sys2: Shift+RButton Popup* |                 | ShiftClick            |
| Sys2: Use File Locking*    |                 | UseFileLock           |
| Sys2: Use Fast Properties* |                 | UseFastProp           |
| Sys2: Auto Backup*         |                 | AutoBack              |
| Sys2: Auto Backup Interval |                 | AutoBackSec           |
| Sys2: Auto Save*           |                 | AutoSave              |
| Sys2: Auto Save Interval   |                 | AutoSaveSec           |
| Sys2: Font Sorting         |                 | FontSort              |
| Settings Dialog option     | <b>TBO</b>      | TabOptions            |
| Text Aspect                |                 | TextAspect            |
| Text Bold*                 |                 | TextBold              |
| Text Char set              |                 | TextCharset           |
| Text Character Spacing     |                 | TextChSp              |
| Text Color                 |                 | TextColor             |
| Text Editor                | <b>TE</b>       | TextEditor            |
| Text Change                |                 | TextCh                |
| Text Fill*                 |                 | TextFill              |
| Text Font                  |                 | TextFont              |
| Text Height                |                 | TextHeight            |
| Text Italic*               |                 | TextItalic            |
| Text Justification         |                 | TextJust              |
| Text Layer                 |                 | TextLay               |
| Text Line                  | <b>TL</b>       | Text                  |
| Text Linetype set          |                 | TextLType             |
| Text Linespacing           |                 | TextLnSp              |
| Text Linewidth set         |                 | TextLWidth            |
| Text Mono*                 |                 | TextMono              |
| Text Rotation              |                 | TextRot               |
| Text Settings              | <b>TT</b>       | TextSet               |
| Text Slant                 |                 | TextSlant             |

| <b>Command Description</b>                | <b>Shortcut</b> | <b>Native Command</b> | <b>Command Description</b>                              | <b>Shortcut</b> | <b>Native Command</b> |
|---|-----------------|-----------------------|---|-----------------|-----------------------|
| Text String                               |                 | TextStr               | Window Stretch  | <b>WS</b>       | WinStretch            |
| Text Settings dialog                      | <b>TBT</b>      | TabText               | Window: Change Properties                               | <b>WG</b>       | WINCHANGE             |
| Text Tab Stops set                        |                 | TextTabStops          | Window: Change Scale                                    | <b>WZ</b>       | WINSCALE              |
| Text Underline*                           |                 | TextUnderln           | Window: Copy Contents                                   | <b>WC</b>       | WINCOPY               |
| Text Use Layer*                           |                 | TextUseLayer          | Window: Erase Contents                                  | <b>WE</b>       | WINERASE              |
| Text Wizard                               | <b>WIT</b>      | WIZTEXT               | Window: Fill Selection                                  | <b>WF</b>       | WinFill               |
| Track                                     | <b>TK</b>       | Track                 | Window: Hatch Selection                                 | <b>WH</b>       | WinHatch              |
| Trim Multiple                             | <b>TM</b>       | MTrim                 | Window: Horizontal                                      |                 | WinHoriz              |
| Trim, Single                              | <b>TR</b>       | Trim                  | Window: Move Contents                                   | <b>WM</b>       | WINMOVE               |
| Undo                                      | <b>OO</b>       | Undo                  | Window: Rotate Contents                                 | <b>WT</b>       | WINROTATE             |
| Undo Dimension                            | <b>UD</b>       | UndoDim               | Window: Vertical  |                 | WinVert               |
| Undo Vertex                               | <b>UV</b>       | UndoVertex            | Zoom Autopan  | <b>AA</b>       | ZmAutoPan             |
| Unit of Measure: Centimeters              |                 | UnitCM                | Zoom All  | <b>ZA</b>       | ZmAll                 |
| Unit of Measure: Feet                     |                 | UnitFeet              | Zoom All Views  |                 | ZmAllView             |
| Unit of Measure: Feet & Inches            |                 | UnitFtIn              | Zoom In   | <b>ZI</b>       | ZmIn                  |
| Unit of Measure: Fractional Feet          |                 | UnitFrFt              | Zoom: Name View speedbar                                | <b>NV</b>       | NameView              |
| Unit of Measure: Fractional Feet & Inches |                 | UnitFrFtIn            | Zoom: text string for a View Name to be used in scripts |                 | ZmViewName            |
| Unit of Measure: Fractional Inches        |                 | UnitFrIn              | Zoom Out  | <b>ZO</b>       | ZmOut                 |
| Unit of Measure: Inches                   |                 | UnitInch              | Zoom Previous   | <b>ZP</b>       | ZmPrev                |
| Unit of Measure: Kilometers               |                 | UnitKM                | Zoom Selected   | <b>ZS</b>       | ZmSel                 |
| Unit of Measure: Meters                   |                 | UnitMeter             | Zoom Value  | <b>ZU</b>       | ZmValue               |
| Unit of Measure: Miles                    |                 | UnitMile              | Zoom View   | <b>ZN</b>       | ZmView                |
| Unit of Measure: Millimeters              |                 | UnitMM                | Zoom Window   | <b>ZW</b>       | ZmArea                |
| Update Dialog                             |                 | Update                |   |                 |                       |
| Use Layer Properties ON/OFF*              | <b>BL</b>       | UseLayProp            |   |                 |                       |
| Use Placement Color ON/OFF*               |                 | UseSymClr             |   |                 |                       |
| User Interface Off                        |                 | UIOff                 |   |                 |                       |
| User Interface On                         |                 | UIOn                  |   |                 |                       |
| Vertical Dimension                        | <b>D2</b>       | DimVert               |   |                 |                       |

# LINETYPES AND LINEWIDTHS

## Linetypes

Visual CADD ships with 50 default linetypes. You can modify existing linetypes, or create new ones, up to a total of 256. See Chapter 13, *Customizing Visual CADD* for more details.

|          |           |
|----------|-----------|
| SOLID    | FL___X2   |
| TYPE___1 | FL___X3   |
| TYPE___2 | PAVED_RD  |
| TYPE___3 | GRKELRD   |
| TYPE___4 | DIR___RD  |
| DASHDOT  | TIE_LINE  |
| TYPE___5 | DITS___X1 |
| DIVIDE   | DITS___X2 |
| TYPE___8 | DITS___X3 |
| DOT      | DOTS___X1 |
| DASHED   | DOTS___X2 |
| HIDDEN   | DOTS___X3 |
| CENTER   | VWTR___X1 |
| PHANTOM  | VWTR___X2 |
| BORDER   | VWTR___X3 |
| COLD___W | GAS___X1  |
| HOT___W  | GAS___X2  |
| RETURN_W | GAS___X3  |
| VENT___  | SAN___X1  |
| PL___X1  | SAN___X2  |
| PL___X2  | SAN___X3  |
| PL___X3  | BORDR_X1  |
| CL___X1  | BORDR_X2  |
| CL___X2  | BORDR_X3  |
| CL___X3  | DASHED 48 |
| FL___X1  |           |

## Linewidths

Visual CADD provides 16 predefined line widths, based on pixel widths. Note that LW 0 and LW 1 both display at one pixel onscreen, although LW 0 will print at the smaller width as shown in the Inches and Metric settings below.

| Number | Inches | Metric | Onscreen  | Sample |
|--------|--------|--------|-----------|--------|
| 0      | .0078  | .2     | 1 pixel   |        |
| 1      | .0156  | .4     | 1 pixel   |        |
| 2      | .0234  | .6     | 2 pixels  |        |
| 3      | .0312  | .8     | 3 pixels  |        |
| 4      | .0390  | 1.0    | 4 pixels  |        |
| 5      | .0468  | 1.2    | 5 pixels  |        |
| 6      | .0546  | 1.4    | 6 pixels  |        |
| 7      | .0624  | 1.6    | 7 pixels  |        |
| 8      | .0702  | 1.8    | 8 pixels  |        |
| 9      | .0780  | 2.0    | 9 pixels  |        |
| 10     | .0858  | 2.2    | 10 pixels |        |
| 11     | .0936  | 2.4    | 11 pixels |        |
| 12     | .1014  | 2.6    | 12 pixels |        |
| 13     | .1092  | 2.8    | 13 pixels |        |
| 14     | .1170  | 3.0    | 14 pixels |        |
| 15     | .1248  | 3.2    | 15 pixels |        |

Visual CADD also supports Real World line widths. A Real World line width is actual width. You specify the width in real world terms; i.e., .5", 2mm, etc. Because of this, RW widths are subject to scaling during printed output and on the screen display depending on the zoom level. For example, a pixel line width will appear the same thickness on the screen no matter how much you zoom in and out. But a Real World linewidth of .5" will appear larger when you zoom in and smaller when you zoom out.

To specify a real world linewidth, select the last item in the main toolbar linewidth dropdown, and then type a value in the edit box. Or on the speedbar of the *Properties* and *Change*

commands, click the RW button and then type a value in the edit box.

Real World Linewidth values in the edit box will display with the unit value you have currently set on the *Enter & Display Unit* dropdown of the *Numeric Tab* dialog. For instance, if you type 12" into the linewidth box on the main toolbar but your units are set to feet, the value will display as 1'.

# ENTERING NUMBERS IN VISUAL CADD

In Visual CADD, you enter numbers to define coordinates, distances, angles, and sizes.

At any time, you can enter coordinates and distances in another measurement system by entering the abbreviation for the system after the number. For example, if your current unit of measure is feet and inches, you can enter meters by typing **m** after the number.

On the Numeric screen of the Settings dialog, you can set the unit of measurement used to enter and display numbers in the status bar and dimension strings.

## Mathematical Expressions

You can enter mathematical expressions to have Visual CADD calculate a value. Visual CADD evaluates mathematical expressions in the following order:

- Numbers or subexpressions enclosed in parentheses
- Trigonometric or exponential functions
- Multiplication
- Addition or subtraction

Operations of equal priority are carried out from left to right.

## Measurement Abbreviations:

| Abbreviation | Units           |
|--------------|-----------------|
| "            | Inches          |
| '            | Feet            |
| ' "          | Feet and Inches |
| mm           | Millimeter      |
| cm           | Centimeter      |
| m            | Meter           |

## Formats for Entering Numbers:

| Format    | Distinction                                     |
|-----------|---|
| 3'6"      | No space between the foot mark and inches value |
| 3' 6"     | Space between the foot mark and inches value.   |
| 3'6       | Inch mark omitted                               |
| 3' 6 1/2" | Mixed feet/inches/fraction                      |
| 3'6.5"    | Mixed feet/decimal inches                       |
| 3.5'      | Decimal feet                                    |
| 3' 1/2'   | Fractional feet                                 |
| 3.5m      | No space between number and abbreviation        |
| 3.5 m     | Space between number and abbreviation           |

NOTE: Visual CADD interprets a hyphen separating feet and inches as a mathematical expression (e.g., entering 5'-4" results in a measurement of 4' 8"). Similarly, it interprets fractions not separated from inches by a space as a mathematical expression.

## Mathematical Expressions:

| Format                            | Result                      |
|-----------------------------------|-----------------------------|
| $2^*3$                            | 6                           |
| $2^*3-1$                          | 5                           |
| $6^*3-1/4$                        | 17.75                       |
| $6^*(3-1/4)$                      | 16.5                        |
| $23' 6 1/2''$<br>$+ 9' 4 1/2''*2$ | 42.29166667' or 42' 3 1/2'' |

## Operators for Mathematical Expressions:

| Operator    | Function                                       |
|-------------|--|
| +           | Adds preceding value to following value        |
| -           | Subtracts following value from preceding value |
| *           | Multiplies preceding and following values      |
| /           | Divides preceding value by following value     |
| \$SIN(A)    | Sine of A                                      |
| \$COS(A)    | Cosine of A                                    |
| \$TAN(A)    | Tangent of A                                   |
| \$ATN(A)    | Arc or inverse tangent of A                    |
| \$LOG(A)    | Log (base 10) of A                             |
| \$NLN(A)    | Natural log (base E) of A                      |
| (A)\$EXP(B) | Exponent (A to the B power)                    |
| \$SQR(A)    | Square of A (A to the 2nd power)               |
| \$SQT(A)    | Square root of A                               |
| \$ABS(A)    | Absolute value of A                            |

# INDEX

## Numerics

- 2-Point Arc tool 43
- 2-Point Circle tool 42
- 2-Point Rectangle tool 41
- 3-Point Arc tool 43
- 3-Point Circle tool 43
- 3-Point Rectangle tool 41

## A

- Absolute coordinates 14
- Advanced Ortho 52
- Align command 82
- Angle Measurement 106
- Angular dimension tool 94
- Aperture 58, 68
- Arc tools
  - 2-Point Arc 43
  - 3-Point Arc 43
  - Elliptical Arc 43
- Area measurement 106
- Array Copy 86
- Assign Script 144
- Attributes
  - attaching 126
  - changing properties 125
  - creating 125
  - displaying 124
  - edit 126
  - embedding 126
  - loading 125
  - move 126
  - parts of an 124
  - positioning 125
  - saving 125
- Auto fillet 83
- AutoCAD
  - color mapping 171
  - font mapping 170
  - opening a file 167
  - paper space 168
  - saving a file 167
  - sharing files with 167
  - translation settings 168
  - Xrefs 168

Autopan 62

## B

- Background Color 18
- Backup files 11
- Backward Redraw 141
- Basepoint coordinates 14
- Bearings 133
- Birds-Eye View 63, 141
- BMP file 179
- Boolean
  - intersection 90
  - subtraction 90
  - union 90
- Breaking
  - break 74
  - multibreak 74

## C

- Center Polygon tool 42
- Chamfer 83
- Change Command 91
- Circle tools
  - 2-Point Circle 42
  - 3-Point Circle 42
  - Diameter Circle 42
- Clear Drawing 73
- Closing a drawing 11
- Color
  - background 18
  - selection 18
- Combining objects 89
- Complex Curve tools 44
- Configuration Editor 148
- Constraining
  - Lines 50
  - Objects 50
- Constraining Snaps 56
- Constraint dialog 50
- Construction points 45
- Context-sensitive help 4
- Continuous Bezier tool 44
- Continuous Line tool 39
- Control points 45
- Coordinate system 13
- Coordinates
  - absolute 14
  - basepoint 14
  - relative 14
- Copy OLE objects 162

## Copying

- Array Copy 86
    - between applications 162
    - between drawings 161
    - importing text 162
  - Linear Copy 85
  - Mirror Copy 86
  - Multiple Copy 85
  - Radial Copy 86, 87
  - Single Copy 86
  - Creating export files 165
  - Creating symbols 122
  - Cumulative Dimensions 94
  - Cursor Free 50
  - Cursor size 15
  - Curve
    - changing the shape of a 45
  - Custom Commands 146
  - Customer Service 6
  - Customizing
    - an overview 143
    - Configuration Editor 148
    - custom commands 146
    - hatch patterns 155
    - keyboard shortcuts 147
    - menus 149
    - new line types 157
    - right-click menus 151
    - toolbars 153
- ## D
- Datum Dimension tool 96
  - Default settings 15
  - Default Tool 17
  - Deleting entities 72
  - Deselecting objects 67
  - Diameter Circle tool 43
  - Diameter Dimension tool 95
  - Digitizer
    - align drawing 140
    - scale 140
    - tablet mode 140
  - Digitizing a drawing 140
  - Dimension text settings 101
  - Dimension tools
    - angular dimension 94
    - datum dimension 96
    - diameter dimension 95
    - linear dimension 94
    - multiple dimension 96

- ordinate dimension 95
- radial dimension 95
- Dimensions
  - adjusting settings 97
  - cumulative 94
  - editing 96
  - modifying 96
  - moving a dimension arc 97
  - moving a dimension line 97
  - moving dimension text 97
  - partitioned 94
  - sliding dimension text 97
- Direct plotting 180
- Direct-Distance entry 38
- Distance Measurement 105
- Divide tool 89
- Documentation
  - online help 4
  - Users Guide 4
- Double Line tool 39
  - setting the offset 40
- Draw Order Commands 91
- Drawing
  - a parallel line 57
  - a perpendicular line 56
  - a tangent line 56
  - by placing points 38
  - close 11
  - leaders 103
  - objects, overview 37
  - opening existing 11
  - save as new file 11
  - saving 11
  - starting a new 11
  - using a grid 53
  - using direct-distance entry 38
  - using Ortho mode 49
  - using polar coordinates 38
  - using snaps 54
  - version control 11
  - when to use line tools 39
  - with precision 49
  - with straight line tools 39
- Drawing tools
  - 2-Point Arc 43
  - 2-Point Circle 42
  - 2-Point Rectangle 41
  - 3-Point Arc 43
  - 3-Point Circle 43

- 3-Point Rectangle 41
- arc tools 43
- Center Polygon 42
- circle tools 42
- complex curve tools 44
- Continuous Bezier Curve 44
- Continuous Line 39
- Diameter Circle 43
- Double Line 39
- Ellipse 42, 43
- Elliptical Arc 43
- Introduction 37
- Irregular Polygon 42
- Midline 39
- MultiLine 40
- polygon tools 42
- rectangle tools 41
- Side Polygon 42
- Single Bezier Curve 44
- Single Line 39
- Spline Curve 44
- straight line tools 39

## E

- Edit 114
- Editing
  - dimensions 96
  - text 113
- Ellipse tool 42, 43
- Elliptical Arc tool 43
- E-mail address 6
- Embedding Objects 163
- EMF file 179
- Environment Save 19
- EPS file 166
- Erase Last 73
- Exit Visual CADD 11
- Explode Continuous Lines 17
- Exploding objects 84
- Export files
  - CADD 167
  - Images 179
  - PDF 178
- Expressions
  - mathematical 199
- Extend commands
  - Extend Multiple 76
  - Extend Single 75
- Extending lines to objects 75

## F

- Fast Properties 47
- File formats 165
- File Locking 21
- Files
  - auto backup 21
  - auto save 21
- Fill Settings 127
- Fillet
  - auto fillet 83
  - radius 83
- Finding Coordinates 59
- Fit Scale 80
- Flipping a symbol 120
- Font conversion
  - AutoCAD 118
  - Generic CADD 118
- Font Manager dialog 116
- Font mapping
  - AutoCAD 170
  - Generic CADD 170
- Fonts
  - vector 115

## G

- General settings dialog 24
- Generic CADD
  - font mapping 170
  - opening a file 167
  - saving a file 167
  - sharing files with 167
  - translation settings 168
- GIF file 179
- Grid 53
- Group commands 72

## H

- Handle points 45
- Hatch Change 128
- Hatch patterns
  - changing 128
  - creating 155
- Hatch settings 127
- Help
  - context-sensitive 4
- HP-GL file 166
- HP-GL/2 183

## I

- Image

- place in drawing 132
- settings 132
- Image Export 179
- Importing text 162
- Increment Snap 50
- Insert OLE Object 164
- Inserting an Image 132
- Installation
  - Additional Software 3
  - Install Options 2
- Installing Visual CADD 1
- Intersection 90
- Irregular Polygon tool 42
- Isometric Mode 48

## J

- Join Command 84
- JPG file 179

## K

- Keyboard Shortcuts 12

## L

- Layer Groups
  - apply a Group 33
  - creating 32
  - deleting 33
  - modifying 33
- Layer Manager settings 30
- Layers
  - assigning properties 33
  - change current layer 31
  - copy to another 31
  - display 31
  - hide 31, 141
  - in a drawing 30
  - lock or unlock 31
  - make non-printable 31
  - move to another 31
- Leader Text dialog 105
- Leaders 103
- Line Scale 47
- Line types 38
  - creating 157
- Line Width 39
- Linear Copy 85
- Linear dimension tool 94
- Linking Objects 163
- List of Linetypes 197
- List of Linewidths 197

- Loading a style 36
- Locking a drawing 11

## M

- Manual, using the 4
- Match Entity tool 130
- Match Tool 130
- Mathematical expressions 199
- Mathematical operators 200
- Measurement
  - abbreviations 199
- Measuring
  - angles 106
  - areas 106
  - distance 105
- Menus
  - customizing 149
- Merging Drawings 162
- Midline tool 39
- Mirror Copy 86
- Move Point 78

## Moving

- a dimension arc 97
- a dimension line 97
- and rotating with Align 82
- dimension text 97
- objects 77

- MultiBreak 74

## MultiLine

- MultiLine Style 40
- MultiLine tool 40
- Multiple Copy 85
- Multiple dimension tool 96
- Multiple windows 64

## N

- name a layer 31
- Numbers
  - formats for entering 199
- Numeric settings 26

## O

- Object Information 107
- Objects
  - changing properties 91
  - move & rotate 82
  - moving 77
  - reshaping 77
  - resizing 79
  - rotating 81

- Offset Command 88

## OLE

- copy to another app 162
- embedding 163
- linking 163
- Online Help 4
- Online Store 6
- Open a backup drawing 11
- Open a drawing 11
- Operators, mathematical 200
- Ordinate dimension tool 95
- Organizing drawings 29
- Ortho mode
  - advanced ortho 52
  - change base angle 51
  - turning on and off 51
- Other applications 161
- Output as CADD 167
- Output as Image 179
- Output as PDF 178

## P

- Pack Data 141
- Panning
  - pan command 62
  - with a mouse wheel 61
- Parallel line 57
- Partitioned Dimensions 94
- Paste OLE Object 164
- PDF files 178
- Pen Up 39, 85
- Perpendicular line 56
- Planning your Drawing 13
- Plotting
  - connection settings 181
  - custom plot configuration 182
  - increasing speed 183
  - pen mapping settings 181
  - plotter language settings 182
- PNG file 179
- Points
  - construction points 45
  - control points 45
  - handle points 45
  - placing points 38
  - standard 44
  - types 44
- Polar Coordinates 38
- Polygon
  - Merge 90

- Split 90
- Polygon tools
  - Center Polygon 42
  - Irregular Polygon 42
  - Side Polygon 42
- Postscript files 166
- Print
  - adjust settings 175
  - options 175
  - presets 177
  - scale 175
- Print settings 174
- Printing
  - entire drawing 176
  - increasing speed 183
  - portion of a drawing 176
  - print presets 177
  - print scale 175
  - selecting a printer 176
  - setting margins 176
  - to file 176
- Properties
  - layers 33
  - setting by example 129
- Properties command 46
- Q**
- Quick Snaps 55
- R**
- Radial Copy 86, 87
- Radial dimension tool 95
- Real World Linewidths 39, 197
- Rectangle tools
  - 2-Point Rectangle 41
  - 3-Point Rectangle 41
- Redraw
  - a portion of a drawing 74
  - newest objects first 68, 74
- Reference frames
  - adjusting 137
  - creating 136
  - display options 138
  - placing 137
- Relative coordinates 14
- Rendering
  - Fills 126
  - Hatches 126
- Rotating
  - and moving with Align 82

- Rotation angle 81
- Running snaps 57
- S**
- Saving
  - a drawing 11
  - a style 35
- Scaling an object 79
- Scripts
  - assigning 144
  - common elements 144
  - examples 144
  - overview 143
  - running at startup 145
- Scrollbars 61
- Search Tolerance 16, 58
- Selecting objects 67
- Selection Color 68
- Selection filters 70
- Selection settings
  - Backward Redraw 68
  - Quick Search 68
  - Search Tolerance 68
- Selection tool
  - deselecting 68
  - selecting 68
- Selection tools
  - Adjoining 70
  - All 69
  - Clear List 70
  - Crossing 69
  - Invert List 70
  - Last 69
  - Layer 70
  - Modified 69
  - Object 69
  - Window 69
- Setting Angles quickly 131
- Setting Distances quickly 131
- Setting up a drawing 15
- Settings
  - Constraint 50
  - Dim Text 101
  - Dimension 98
  - Font Manager 116
  - General 24
  - Hatch/Fill 127
  - Leader 103
  - Leader Text 105
  - Numeric 26

- System1 17
- System2 19
- Shaping curves 45
- Shortcut keys 185
- Side Polygon tool 42
- Single Bezier Curve tool 44
- Single Copy 86
- Single Line tool 39
- Skew tool 80
- Snaps
  - Quick Snaps 55
  - Running snaps 57
  - Snap Between 2 Points 54
  - Snap Center 54
  - Snap Closest 54
  - Snap Intersection 54
  - Snap Last 55
  - Snap Midpoint 54
  - Snap Near Point 55
  - Snap Object 54
  - Snap Parallel 56
  - Snap Percentage 55
  - Snap Perpendicular 56
  - Snap Quadrant 55
  - Snap Tangent 56
  - snaps that prompt 54
- Spell Checking 114
- Spline Curve tool 44
- Standard points 44
- Starting a drawing 11
- Starting Visual CADD 7
- Stretch 78
- Styles
  - categories 35
  - loading 36
  - saving 35
  - why use them 35
- Subtraction 90
- Support services 5
- Symbol Manager 120
- Symbols
  - attaching attributes 124
  - creating 122
  - exploding 123
  - flipping 120
  - handle point 122
  - introduction 119
  - loading 121
  - placing 121

- removing 123
- replacing 123
- saving 123
- temporary handle 122
- System requirements 1
- System1 settings 17
- System2 settings 19

## **T**

- Tangent line 56
- Technical Support
  - checklist 5
  - E-mail 6
  - website 6

## **Text**

- adding 109
- all on same layer 110
- changing properties 113
- check spelling 114
- choosing fonts 115
- cursor size 110
- editing 113
- importing 162
- overview 109
- placing 110
- properties 111
- size 110
- spellchecker options 115
- Text Line tool 112

- Text Editor 112
- Text line settings

- Text Line tab 111
- Text Settings tab 111
- Vector Settings tab 112

- Text Line tool 111

- TIFF file 179

- Track 59, 60

- Track End 60

- Tracking 59

- Translation settings

  - AutoCAD 168

  - Generic CADD 168

- Trim commands

  - Trim Intersection 76

  - Trim Multiple 76

  - Trim Single 76

- Trimming lines 76

- Tutorial 7

- Typographical conventions 4

## **U**

- Understanding CADD 9

- Undoing actions 72

- Union 90

- Users group 6

- Using a Digitizer 139

- Using Documentation 3

## **V**

- Vector

  - fonts 115

  - settings for text 112

- Version control 11

- Viewing your drawing 61
- Visual CADD Group, The 6

## **W**

- Windows, using multiple 64

- WMF file 166, 179

- Workspace 8

- World Wide Web address 6

## **X**

- X,Y coordinates 38

- XML files 13, 148, 173

## **Z**

- Zoom tools

  - All 62

  - Autopan 62

  - Birds-Eye View 63

  - In 62

  - Out 62

  - Pan 62

  - Previous 63

  - Selected 62

  - Value 63

  - Wheel Mouse 61

  - Window 62

- Zooming

  - deleting a named view 64

  - naming views 64

  - using a named view 64